

# EC-RP3

Installation position

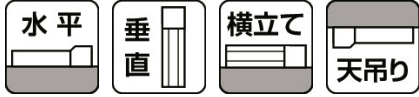

Catalog PDF	Instruction manual PDF
2D CAD drawings	Parametric CAD Drawings
Request information	



[Dimensions](#)   [Selection considerations](#)   [Adaptive Controller](#)

## Main Specifications

Specification 1		Specification 2			
item		Contents			
Lead	Ball screw lead (mm)	6	4	2	
	Payload capacity	Maximum payload (kg)	1.5	3	6
Horizontal	Speed/Acceleration	Maximum speed (mm/s)	300	200	100
		Minimum speed (mm/s)	8	5	3
		Rated acceleration/deceleration (G)	0.3	0.3	0.3
		Maximum acceleration/deceleration (G)	0.3	0.3	0.3
vertical	Payload capacity	Maximum payload (kg)	0.5	1	2
	Speed/Acceleration	Maximum speed (mm/s)	300	200	75
		Minimum speed (mm/s)	8	5	3
		Rated acceleration/deceleration (G)	0.3	0.3	0.3
		Maximum acceleration/deceleration (G)	0.3	0.3	0.3
Pressing	Maximum thrust when pressing (N)	14	twenty one		42
	Maximum pressing speed (mm/s)	20	20	5	
brake	Brake Specifications	Non-excitation electromagnetic brake			
	Brake holding force (kgf)	0.5	1	2	
stroke	Minimum stroke (mm)	30	30	30	
	Maximum stroke (mm)	100	100	100	
	Stroke pitch (mm) (30 to 50ST)	20	20	20	
	Stroke pitch (mm) (50 to 100ST)	twenty five	twenty five	twenty five	

## ▶ Payload table by speed/acceleration

Standard grease specifications. The unit of payload is kg. Blank spaces indicate that the product cannot be operated.

Lead 6	Lead 4	Lead 2
posture	Horizontal	vertical
speed (mm/s)	Acceleration (G)	
		0.3
0	1.5	0.5
50	1.5	0.5
100	1.5	0.5
150	1.5	0.5
200	1.5	0.3
250	1	0.3
300	1	0.2

If the ambient temperature is below 5° C, use the product at or below the speeds listed below.

- Lead 6: 200mm/s or less
- Lead 4: 150mm/s or less
- Lead 2: 50mm/s or less

Food grade grease specifications. The unit of payload is kg. Blank spaces indicate that the product cannot be operated.

Lead 6	Lead 4	Lead 2
posture	Horizontal	vertical
speed (mm/s)	Acceleration (G)	
		0.3
0	1.5	0.5
50	1.5	0.5
100	1.5	0.5
150	1.5	0.5
200	1.5	0.3
250	1	

## ▶ Stroke and maximum speed

(Unit: mm/s)

Lead (mm)	30 (mm)	50 (mm)	75 (mm)	100 (mm)
6	300			
4	200			
2	100<75>			

(Note) Values in < > are for vertical use.

## Correlation diagram between pressing force and current limit value

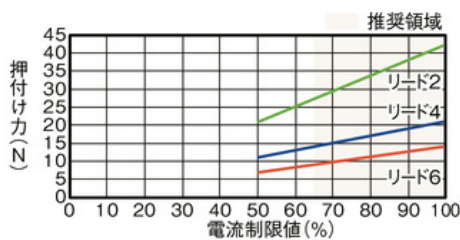

### Precautions when performing pressing operation

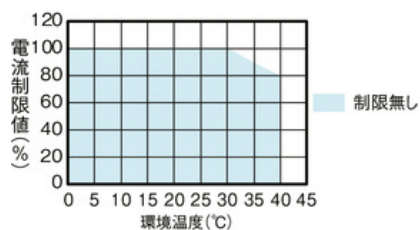

When performing high thrust pressing operations in a high temperature environment, please use within the limit values shown in the graph.

## Adaptive Controller

(Note) The EC series has a built-in controller. For details on the built-in controller, see page [2-769](#).

## International Standards



## Selection considerations

選定上の  
注意



- (1) The feed screw does not have a rotation prevention mechanism, so when using it, add a rotation prevention mechanism such as a guide to the end.
- (2) The payload capacity in the "Main Specifications" is the maximum value. For details, please refer to the "Payload Capacity by Speed and Accel".
- (3) The horizontal payload capacity is when used in conjunction with an external guide. Do not apply external force from any direction other than the horizontal.
- (4) When performing a pressing operation, please refer to the "Correlation Diagram of Pressing Force and Current Limit Value." The pressing force is the force applied to the workpiece.

[↑ Back to top of page](#)

## Dimensions

ST: Stroke

ME: Mechanical end

SE: Stroke end

(Note) When performing a return to origin, the rod moves to the ME, so be careful not to let it interfere with surrounding objects.

Note: Make sure to secure the cable so that the base of the cable does not move.

The cable can be separated and replaced (connected via the connector inside the cable box).

The standard direction for the actuator cable to exit is from the rear.

The cable exit direction (optional) can be changed by changing the direction of the cable box.

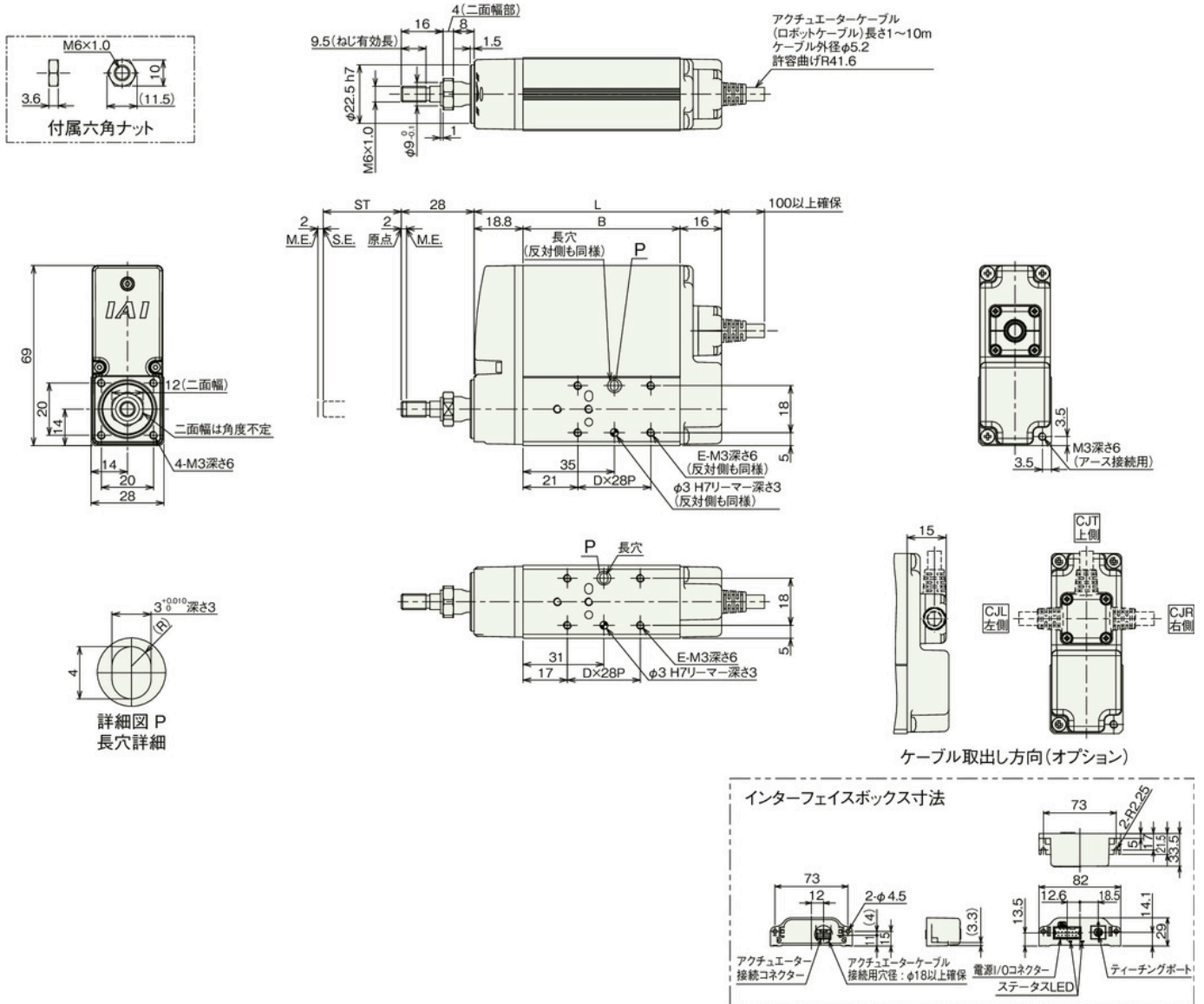

Stroke dimensions

stroke		30	50	75	100
L	No brakes	95	115	140	165
	With brake	140	140	140	165
B	No brakes	60.2	80.2	105.2	130.2
	With brake	105.2	105.2	105.2	130.2
D	No brakes	1	1	2	3
	With brake	2	2	2	3
E	No brakes	4	4	6	8

	With brake	6	6	6	8
--	------------	---	---	---	---

Mass by stroke

stroke		30	50	75	100
Mass (kg)	No brakes	0.37	0.41	0.47	0.53
	With brake	0.54	0.54	0.54	0.60

[↩ Back to product information top](#)