

# Overseas Standards Compliance Manual

---

(CE/UL)  
Twentieth Edition

***IAI Corporation***



## Please Read Before Use

Thank you very much for purchasing our product.

In this manual, describes how our products comply with the standards of the countries outside Japan and the detailed information regarding the compliances.

For some of our products, the entire system including the connections to the peripheral devices requires to be equipped with counteractions and certificated if it is to be complied with the law. Check the local law.

Please read this manual as well as the Instruction Manual before start using the product if it is necessary to comply with an overseas standard.

Also, our products are designed and sold assuming they would be installed in a system inside a factory by an educated and trained person.

In order for you to use that system in safe, follow ISO12100 and conduct a risk assessment.

By doing so, have risks that could be considered reduced and removed to the acceptable level.

Please downloaded the user's manual from our website.

You can download it free of charge. User registration is required for the first time downloading.

URL : [www.iai-robot.co.jp/data\\_dl/CAD\\_MANUAL/](http://www.iai-robot.co.jp/data_dl/CAD_MANUAL/)

When using the product, print out of the necessary portions of the relevant manual, or please display it on your computer, tablet terminal, etc. so that you can check it immediately.

After reading through this manual, keep this Instruction Manual at hand so that the operator of this product can read it whenever necessary.

### **[Important]**

- This is the original manual explaining the compliance of IAI products with the overseas standards.
- The contents written in this manual may change without notice on the update of the products, overseas standards and so on.
- If you have any question or comment regarding the content of this instruction manual, please contact the IAI sales office near you.
- Using or copying all or part of this Instruction Manual without permission is prohibited.
- The company names, names of products and trademarks of each company shown in the sentences are registered trademarks.

# Contents

Compliance of IAI Corporation to Safety Standards	Intro-1
---	---------

## Chapter 1 Overseas Standards Compliance List

1.1 Overseas Standards Compliance List (Actuator)	1-1
1.2 Overseas Standards Compliance List (Controller)	1-7
1.3 Option	1-9

## Chapter 2 CE Marking

2.1 About CE Marking	2-1
2.2 Compliance Standards	2-3
2.3 Details of Caution Labels Attached on Devices	2-5
2.4 Environment	2-7
2.4.1 Operating Environment	2-7
2.4.2 Installation Environment	2-10
2.4.3 Storage Environment	2-11
2.5 Space Required for Actuator Maintenance Inspection (Unit: mm)	2-12
2.6 Power Supply	2-18
2.7 Grounding	2-19
2.8 Construction of Peripheral Devices and Applicable Units	2-20
2.8.1 ROBONET-RGW	2-23
2.8.2 MSEP-C/LC, MCON-C/CG, MCON-LC/LCG	2-25
2.8.3 PMEC-C (200V AC Power Supply Type)	2-27
2.8.4 ACON-C/CG/CY/PL/PO/SE/CA/CB/CGB/CYB/PLB/POB, DCON-CA/CB/CGB/CYB/PLB/POB, ASEP-C/CW, DSEP-C/CW	2-29
2.8.5 PCON-C/CG/CY/PL/PO/SE/CA/CB/CGB/CBP/CGBP/CYB/PLB/POB, RCP2-C/CF, PSEP-C/CW	2-31
2.8.6 ASEL-C/CS, PSEL-C/CS	2-33
2.8.7 SCON-C/CA/CAL/CGAL/CB/CGB/LC/LCGB SCON-CGB-F (for 3000W and 3300W motors)	2-35
2.8.8 SCON2-CG	2-37
2.8.9 MCON-C	2-39
2.8.10 SSEL-C/CS	2-41
2.8.11 XSEL2	2-43
2.8.12 XSEL-P/RA	2-46
2.8.13 XSEL-Q/SA	2-49
2.8.14 XSEL-PX/RAX/RAXD	2-52

2.8.15	XSEL-QX/SAX/SAXD	2-56
2.8.16	TTA	2-61
2.8.17	ERC/ERC2/ERC3	2-62
2.8.18	MSEL-PC/PG/PCF/PGF	2-64
2.8.19	MSEL-PGX	2-66
2.8.20	RCON-GW/GWG	2-68
2.8.21	RSEL-G	2-70
2.8.22	RCON-SC	2-72
2.8.23	REC	2-74
2.8.24	ELECYLINDER	2-75
2.8.25	ELECYLINDER 200V	2-77
2.8.26	ROBO PUMP	2-78
2.8.27	On-Site Power Supply Unit	2-79
2.8.28	e-Wiring System Connection Unit	2-80
2.9	Components for EMC Counteraction	2-82
2.9.1	Clamp Filter	2-82
2.9.2	Ring Core	2-84
2.9.3	Noise Filter	2-85
2.9.4	Surge Protector	2-95
2.9.5	24V DC Power Supply	2-98
2.10	Protection Equipment to Ensure Safety	2-101
2.10.1	No Fuse Breaker (Circuit Breaker)	2-101
2.10.2	Leakage Breaker	2-103
2.10.3	Contactors	2-104
2.10.4	Safety Relay	2-105
2.10.5	Fuse	2-106

## **Chapter 3 UL Standards**

3.1	About UL Standards	3-1
3.2	UL Standards List	3-2

## **Chapter 4 KCs Marking**

4.1	About KCs Marking	4-1
-----	-------------------	-----

## **Chapter 5 TSCA**

5.1	About TSCA	5-1
-----	------------	-----

## **Chapter 6 China RoHS**

6.1	About China RoHS	6-1
-----	------------------	-----

**Chapter 7 Wireless Communication Compatible**

7.1 About Wireless Communication Compatible..... 7-1  
7.2 Caution Regarding Wireless Devices ..... 7-3

Revision history ..... Post-1

## Compliance of IAI Corporation to Safety Standards

### **1. Regarding UL**

UL (Underwriters Laboratories Inc.) is a non-profit organization established by Board of Fire Underwriters in the U.S. in 1894. It conducts researches, evaluations and inspections to protect human lives and properties from fires, disasters, robberies and other accidents.

The UL Standards are the safety standards for products in relation with functions and safety. UL tests and evaluates a sample of its product. When UL judges complied with the requirements in the US Standards, the product gets allowed to label a UL certification mark on delivery.

For details, refer to [Chapter 1 Overseas Standards Compliance List] described in this manual.

### **2. Regarding EC Directives**

The actuators and controllers of IAI (hereinafter described as IAI components) are to be treated as a component to be used in the structure of a user's equipment (installed device). Therefore, IAI components are individually declared of conformity as a "semifinished product" in "Machine Directive 2006/42/EC". Be aware that it is not that guarantees your equipment itself complies with the EC Directives.

Please ensure the compliance of your system on your own responsibility if your system in which IAI components are included is delivered to the EU countries as a final product or used in those countries.

As a mandatory condition for the compliance of your system to EN60204-1 that is one of the EN standards in Machinery Directive and prescribes the electrical safety of the industrial machineries, it is necessary that IAI components are complied with "Low Voltage Directive 2014/35/EU" and "EMC Directive 2014/30/EU".

IAI components are categorized to those capable of operation with 24V DC power supply only and those capable of operation with 200V AC in the concern of "Low Voltage Directive 2014/35/EU". The former is not subject to the Low Voltage Directive as it is lower than the target voltage ranges (50 to 1000V AC or 75 to 1500V DC). The latter should be regarded as complying with the Low Voltage Directive with assumption that a component is used under the ways of use described in [2.4.1 Operating Environment [Complying with Low Voltage Directive Demands]].

Regarding “EMC Directive 2014/30/EU”, the compliance is declared under the limited condition of use if the EMI actions described in this Overseas Standards are taken. However, it is important that the component is mounted in your system and tested in it.

In addition to those described above, in EC Directive that IAI components are to comply with, there is a requirement to have the specific hazardous substances below the specified values, which is so-called “RoHS Directive 2011/65/EU”.

IAI components have been complied with this directive from early time.

RoHS Directive (2002/95/EC) was established on July 1, 2006 as a directive to restrict use of specific hazardous materials in the distribution in the EU of electrical and electronic equipments. The official gazette “(EU) 2015/863” to replace Annex II in 2011/65/EU that specifies restricted materials in RoHS was issued in Jun 4, 2015. Also the Revised RoHS Directive should comply from July 22, 2019 (July 22, 2021 for Category 9).

After revising, there are new four materials (DEHP, BBP, DBP and DIBP) in addition to the existing restricted six materials, making the subject 10 materials in total (refer to the table below).

Restricted Materials	6 Materials (RoHS Directive (2011/65/EU))	10 Materials (Revised RoHS Directive (2011/65/EU) + (EU) 2015/863)
	Lead	Lead
	Mercury	Mercury
	Cadmium	Cadmium
	Hexavalent Chrome	Hexavalent Chrome
	Polybrominated Biphenyl (PBBs)	Polybrominated Biphenyl (PBBs)
	Polybrominated Diphenyl Ether (PBDEs)	Polybrominated Diphenyl Ether (PBDEs)
		Bis (2-Ethylhexyl) Phthalate (DEHP)
		Butyl Benzyl Phthalate (BBP)
	Dibutyl Phthalate (DBP)	
	Diisobutyl Phthalate (DIBP)	

IAI products should belong to Category 9 (Monitoring / Control Devices).

We completed our compliance by July 22, 2021 except for special specification products and partial of old products. For the detail of completion status, refer to [Chapter 1 Overseas Standards Compliance List] described in this manual.

As described above, the CE Mark attached on an IAI component shows the compliance declaration to RoHS Directive/EMC Directive (related to 24V DC) or RoHS Directive/EMC Directive and Low Voltage Directive (related to 200V) under the limited conditions of use.

IAI components basically apply English as the language used in the instruction manuals and caution labels.

If you need another language to apply, please contact our sales person in charge.

Caution and warning labels may contain Japanese as well as English when they have an explanation.

Also, if your system is necessary to be complied with CE, select the components applicable for each safety category required for your system on your own responsibility, and make sure to construct the external safety circuit for your own system.

### **3. About KCs Korean Autonomous Safety Confirmation Declaration System**

Since 1 March, 2013, industrial robots has become subject to Labor's Safety Certification System in Korea, which regulates products used in Korea and exported to Korea from Japan.

The industrial robots defined in KCs are described as “a fixed robot, including an orthogonal-coordinate robot, capable of programming and automatic control using a dedicated control device, being equipped with manipulators of more than 3 axes (including a control device equipped with actuators and teaching pendant and communication interfaces) ”.

For application of KCs Labor's Safety Certification of the applicable products, submission of necessary documents and application to Korea Occupational Safety and Health Agency (KOSHA) are required.

Registration will be permitted once confirmed no problem, and allowed to label a KCs mark on the product.

The necessary documents are those that the EMC test data and its test site are proved to be officially certified and those expected to be complied with the requirements in the Labor's Safety Certification guide “Industrial Robots” conformed to Article 35 in Occupational Safety and Health Act.

Industrial robots subject to usage in or export to Korea are to be monitored by the agency and products with no KCs mark displayed should not be accepted.

The products of IAI already applied for and registered to KCs are as listed below:

- All products in IX/IXP/IXA SCARA Robot Series (high velocity types)
- Partially in Single-Axis (contact person in charge for sales in IAI for details)
- TTA Table Top Robot Series

For details, please contact our sales person in charge.

#### 4. Regarding about the initiative with TSCA regulations

The US TSCA regulations were revised, and import to and processing and commercial distribution in the U.S. of any product contains PBT5 substances has been prohibited since November 1, 2024.

Along with this, We have identified the parts that contain triphenylphosphate (Isopropylated) and have started to deliver products that comply with TSCA regulations since November 1, 2023. However, for some products (for IO cables of XSEL-P/Q and IO conversion cables for TTA), compatible products have started delivery since middle of November, 2023.



#### Caution

- As some of the old products and maintenance pasts may not have replacement, it will be a product that contains the substance regulated in TSCA.
- As the special specifications may contain substances regulated in TSCA, it is necessary to investigate them individually.

Consult with our person in charge for sales for details.

---

**Overseas Standards  
Compliance Manual**

---

**Chapter 1**

# Overseas Standards Compliance List

1.1	Overseas Standards Compliance List (Actuator) .....	1-1
1.2	Overseas Standards Compliance List (Controller).....	1-7
1.3	Option .....	1-9



# 1.1 Overseas Standards Compliance List (Actuator)

The actuators IA1 that are applicable for the global standards are as shown in the table below.  
The data described in this manual is as June 2, 2025.

◎ : Standard Complied / ○ : Option

△ : Complied Under Special Order / × : No Plan for Compliance

■Actuator

Product Genre	Series Name	Type	Model	Revised RoHS Directive	CE Marking Compliance	UL Standards Compliance	TSCA
ELECYLINDER	EC	Slider (Ultra Mini)	SL3□	◎	◎	◎	◎
		Slider (Standard)	S2(D)S3(□A)(D)S4(□A)(D)S6(□A)(D)S7(□A)S8(X)□A	◎	◎	◎	◎
		Slider (Wide)	(D)WS10□(D)WS12	◎	◎	◎	◎
			(D)WS10□R(D)WS12□R	◎	◎	◎	◎
		Slider (High Stiffness)	(D)S6(X)□AH(D)S7(X)□AH/S8(X)□AH	◎	◎	◎	◎
			(D)S6(X)□AHR(D)S7(X)□AHR/S8(X)□AHR	◎	◎	◎	◎
		Slider (Belt-Drive)	(D)B6(D)B7/B8S	◎	◎	◎	◎
			B8SS	◎	◎	×	◎
		Slider (Large Slider)	S10(X)/S13(X)/S15(X)/S18(X)	◎	◎	×	◎
		Rod (Wire cylinder) (*1)	WER1	◎	◎	◎	◎
		Rod (Ultra Mini)	GDB3	◎	◎	◎	◎
		Rod (Compact)	CRP3/CRP5/CGD3/CGD5	◎	◎	◎	◎
		Rod (Standard)	(D)R6(D)R7	◎	◎	◎	◎
		Rod (Short Length Type)	RP3/RP4/GS4/GD3/GD4/RP5/GD5	◎	◎	◎	◎
		Rod (Double Guide Type)	SRG(C)9/SRG11/SRG15	◎	◎	◎	◎
		Radial Cylinder (Standard)	RR2(D)RR3(D)RR4(D)RR6(D)RR7/RR8/RR10	◎	◎	◎	◎
			RR2□R(D)RR3□R(D)RR4□R(D)RR6□R(D)RR7□R/RR8□R/RR10□R	◎	◎	◎	◎
		Radial Cylinder (High Stiffness)	(D)RR6(X)□AH(D)RR7(X)□AH	◎	◎	◎	◎
			(D)RR6□AHR(D)RR7□AHR	◎	◎	◎	◎
		Table (Ultra Mini)	T3	◎	◎	◎	◎
	Table (Compact)	CTC3/CTC5	◎	◎	◎	◎	
	Table (Short Length Type)	TC3/TC4/TC5/TW3/TW4/TW5	◎	◎	◎	◎	
	Gripper (Wire cylinder) (*1)	WEGR2	◎	◎	◎	◎	
	Gripper	GRB(P)8/GRB(P)10/GRB(P)13/GRC6/GRC7/GRST3/GRST6/GRST7/GRTR14	◎	◎	◎	◎	
	Rotary	RTB4/RTC9/RTC12/RTC18	◎	◎	◎	◎	
	Stopper Cylinder	GDS3(ST)(C)9/ST11/ST15/ST15ME	◎	◎	◎	◎	
	EC (Cleanroom specification)	Slider (Standard)	(D)S3(□A)CR(D)S4(□A)CR(D)S6(□A)CR(D)S7(□A)CR/S8(X)□A)CR	◎	◎	◎	◎
		Slider (High Stiffness)	(D)S6(X)□AHCR(D)S7(X)□AHCR/S8(X)□AHCR	◎	◎	◎	◎
		Slider (Wide)	(D)WS10□CR(D)WS12□CR	◎	◎	◎	◎
	EC (Dustproof/Splash Proof specification)	Slider (Standard)	S6□D/S6□WS7□D/S7□W	◎	◎	◎	◎
		Rod (Standard)	R6□W/R□7W	◎	◎	◎	◎
		Rod (High Stiffness)	RR6□W/RR7□W	◎	◎	◎	◎
		Gripper	GRBP8□W/GRBP10□W/GRBP13□W	◎	◎	◎	◎

\*1 Wire Cylinder is not registered to the UL standards nor declared to EC Conformity as the unit model, but is registered and declared as the wire controller model code "WC-EC".

1.1 Overseas Standards Compliance List (Actuator)

◎ : Standard Complied / ○ : Option

△ : Complied Under Special Order / × : No Plan for Compliance

■Actuator

Product Genre	Series Name	Type	Model	Revised RoHS Directive	CE Marking Compliance	UL Standards Compliance	TSCA
Conveyor Control Motor	CCM	Round Belt Drive	RB7M	◎	◎	×	◎
		V-Belt Drive	VB7M	◎	◎	×	◎
		V-Ribbed Belt Drive	VRB7M	◎	◎	×	◎
ROBO PUMP	RP	Open Atmospheric System	VPM	◎	◎	×	◎
		Vacuum Release	VPMV	◎	◎	×	◎
ROBO Cylinder	RCP6 RCP6S	Slider (Standard)	SA4C/SA6C/SA7C/SA8C	◎	◎	×	◎
			SA4R/SA6R/SA7R/SA8R	◎	◎	×	◎
		Slider (Wide)	WSA10C/WSA12C/WSA14C/WSA16C	◎	◎	×	◎
			WSA10R/WSA12R/WSA14R/WSA16R	◎	◎	×	◎
		Rod (Standard)	RA4C/RA6C/RA7C/RA8C	◎	◎	×	◎
			RA4R/RA6R/RA7R/RA8R	◎	◎	×	◎
		Rod (Radial Cylinder)	RRA4C/RRA6C/RRA7C/RRA8C	◎	◎	×	◎
			RRA4R/RRA6R/RRA7R/RRA8R	◎	◎	×	◎
		Rod (Wide)	WRA10C/WRA12C/WRA14C/WRA16C	◎	◎	×	◎
			WRA10R/WRA12R/WRA14R/WRA16R	◎	◎	×	◎
		Table	TA4C/TA6C/TA7C	◎	◎	×	◎
			TA4R/TA6R/TA7R	◎	◎	×	◎
	RCP6	Slider (High Stiffness)	HSA6(X)/HSA7(X)C	◎	◎	×	◎
			HSA6(X)R/HSA7(X)R	◎	◎	×	◎
		Gripper	GRST6C/GRST7C	◎	◎	×	◎
			GRST6R/GRST7R	◎	◎	×	◎
			GRT7A/GRT7B	◎	◎	×	◎
		Rotary Chuck	RTCKSPE/RTCKMPE	◎	◎	×	◎
			RTCKSPI/RTCKMPI	◎	◎	×	◎
	Hollow Rotary	RTFML	◎	◎	×	◎	
	RCP6CR	Slider (Standard)	SA4C/SA6C/SA7C/SA8C	◎	◎	×	◎
	RCP6SCR	Slider (Wide)	WSA10C/WSA12C/WSA14C/WSA16C	◎	◎	×	◎
	RCP6W RCP6SW	Rod (Standard)	RA4C/RA6C/RA7C/RA8C	◎	◎	×	◎
			RA4R/RA6R/RA7R/RA8R	◎	◎	×	◎
		Rod (Radial Cylinder)	RRA4C/RRA6C/RRA7C/RRA8C	◎	◎	×	◎
			RRA4R/RRA6R/RRA7R/RRA8R	◎	◎	×	◎
		Rod (Wide)	WRA10C/WRA12C/WRA14C/WRA16C	◎	◎	×	◎
			WRA10R/WRA12R/WRA14R/WRA16R	◎	◎	×	◎
	RCP5	Slider (Standard)	SA4C/SA6C/SA7C	◎	◎	×	◎
			SA4R/SA6R/SA7R	◎	◎	×	◎
		Slider (Belt-Drive)	BA4/BA6/BA7/BA4U/BA6U/BA7U	◎	◎	×	◎
			RA4C/RA6C/RA7C/RA8C/RA10C	◎	◎	×	◎
	Rod	RA4R/RA6R/RA7R/RA8R/RA10R	◎	◎	×	◎	
	RCP5CR	Slider	SA4C/SA6C/SA7C	◎	◎	×	◎
	RCP5W	Rod	RA6C/RA7C/RA8C/RA10C	◎	◎	×	◎
	RCP4	Slider	SA3C/SA5C/SA6C/SA7C	◎	◎	×	◎
			SA3R/SA5R/SA6R/SA7R	◎	◎	×	◎
		Rod	RA3C/RA5C/RA6C	◎	◎	×	◎
			RA3R/RA5R/RA6R	◎	◎	×	◎
		Gripper	GRSML/GRSL/GRSWL/GRLM/GRL/GRLL/GRLW	◎	◎	×	◎
	Stopper Cylinder	ST68E/ST615E/ST4525E	◎	◎	×	◎	
	RCP4CR	Slider	SA3C/SA5C/SA6C/SA7C	◎	◎	×	◎
	RCP4W	Slider	SA5C/SA6C/SA7C	◎	◎	×	◎
		Rod	RA6C/RA7C	◎	◎	×	◎
	RCP3	Slider	SA2AC/SA2BC/SA3C/SA4C/SA5C/SA6C	◎	◎	×	◎
			SA2AR/SA2BR/SA3R/SA4R/SA5R/SA6R	◎	◎	×	◎
		Rod	RA2AC/RA2BC	◎	◎	×	◎
			RA2AR/RA2BR	◎	◎	×	◎
		Table	TA3C/TA4C/TA5C/TA6C/TA7C	◎	◎	×	◎
TA3R/TA4R/TA5R/TA6R/TA7R			◎	◎	×	◎	

1. Overseas Standards Compliance List

1.1 Overseas Standards Compliance List (Actuator)

◎ : Standard Complied / ○ : Option

△ : Complied Under Special Order / × : No Plan for Compliance

■Actuator

Product Genre	Series Name	Type	Model	Revised RoHS Directive	CE Marking Compliance	UL Standards Compliance	TSCA
ROBO Cylinder	RCP2	Slider (Standard)	SA5C/SA6C/SA7C/SS7C/SS8C	◎	◎	×	◎
			SA5R/SA6R/SA7R/SS7R/SS8R	◎	◎	×	◎
		Slider (Belt-Drive)	BA6/BA7/BA6U/BA7U	◎	◎	×	◎
		Slider (High-Speed)	HS8C/HS8R	◎	◎	×	◎
		Rod (Standard)	RA2C/RA3C/RA4C/RA6C/RA8C/RA10C	◎	◎	×	◎
			RA3R/RA4R/RA6R/RA8R/SRA4R	◎	◎	×	◎
		Rod (With Guide)	RGS4C/RGS6C/RGD3C/RGD4C/RGD6C	◎	◎	×	◎
			SRGS4R/SRGD4R	◎	◎	×	◎
		Gripper	GRLS/GRSS/GRS/GRM/GRHM/GRHB	◎	◎	×	◎
			GR3LM/GR3LS/GR3SM/GR3SS	◎	◎	×	◎
			GRST	◎	◎	×	◎
		Rotary	RTBS/RTBSL/RTB/RTBL/RTBB/RTBBL	◎	◎	×	◎
			RTCS/RTCSL/RTC/RTCL/RTCB/RTCBL	◎	◎	×	◎
	Simple Absolute Type	Simple Absolute Applicable Models	◎	◎	×	◎	
	RCP2CR	Slider	SA5C/SA6C/SA7C/SS7C/SS8C/HS8C	◎	◎	×	◎
		Gripper	GRSS/GRLS/GRS/GRM/GR3SS/GR3SM	◎	◎	×	◎
		Rotary	RTBS/RTBSL/RTCS/RTCSL/RTB/RTBL/RTC/RTCL/RTBB/RTBBL/RTCB/RTCBL	◎	◎	×	◎
	RCP2W	Rod (Standard)	RA4C/RA6C	◎	◎	×	◎
		Rod (High Thrust)	RA10C	◎	◎	×	◎
		Gripper	GRSS/GRLS/GRS/GRM/GR3SS/GR3SM	◎	◎	×	◎
		Rotary	RTBS/RTBSL/RTCS/RTCSL/RTB/RTBL/RTC/RTCL/RTBB/RTBBL/RTCB/RTCBL	◎	◎	×	◎
	ERC3	Slider	SA5C/SA7C	◎	◎	×	◎
		Rod	RA4C/RA6C	◎	◎	×	◎
	ERC3D	Slider	SA5C/SA7C	◎	◎	×	◎
	ERC3CR	Slider	SA5C/SA7C	◎	◎	×	◎
	ERC2	Slider	SA6C/SA7C	◎	◎	×	◎
		Rod (Standard)	RA6C/RA7C	◎	◎	×	◎
		Rod (With Guide)	RGS6C/RGS7C/RGD6C/RGD7C	◎	◎	×	◎
	ERC	Slider	SA6/SA7	◎	◎	×	◎
		Rod	RA54/RA64	◎	◎	×	◎
	RCD	Rod	RA1DA/RA1D	◎	◎	×	◎
		Gripper	GRSNA/GRSN	◎	◎	×	◎
	RCA2	Slider	SA2AC/SA3C/SA4C/SA5C/SA6C	◎	◎	×	◎
			SA2AR/SA3R/SA4R/SA5R/SA6R	◎	◎	×	◎
		Rod	RA2AC/RA2AR/RN3N/RN4N/RP3N/RP4N	◎	◎	×	◎
			GS3N/GS4N/GD3N/GD4N/SD3N/SD4N	◎	◎	×	◎
			RN3NA/RN4NA/RP3NA/RP4NA/GS3NA/GS4NA	◎	◎	×	◎
			GD3NA/GD4NA/SD3NA/SD4NA	◎	◎	×	◎
		Table (Short Length Type)	TC(N)3N/TC(N)4N/TW(N)3N/TW(N)4N/TF(N)3N/TF(N)4N	◎	◎	×	◎
			TCA3N/TCA4N/TWA3N/TWA4N/TFA3N/TFA4N	◎	◎	×	◎
			TCN3NA/TCN4NA/TWN3NA/TWN4NA/TFN3NA/TFN4NA	◎	◎	×	◎
			TCA3NA/TCA4NA/TWA3NA/TWA4NA/TFA3NA/TFA4NA	◎	◎	×	◎
		Table (Standard)	TA4C/TA5C/TA6C/TA7C	◎	◎	×	◎
			TA4R/TA5R/TA6R/TA7R	◎	◎	×	◎
		RCA2CR	Rod	RN3NB/RN4NB/RP3NB/RP4NB/GS3NB/GS4NB	◎	◎	×
	GD3NB/GD4NB/SD3NB/SD4NB			◎	◎	×	◎

1.1 Overseas Standards Compliance List (Actuator)

◎ : Standard Complied / ○ : Option

△ : Complied Under Special Order / × : No Plan for Compliance

■Actuator

Product Genre	Series Name	Type	Model	Revised RoHS Directive	CE Marking Compliance	UL Standards Compliance	TSCA
ROBO Cylinder	RCA2W	Rod	RN3NA/RN4NA/RP3NA/RP4NA/GS3NA/GS4NA	◎	◎	×	◎
			RN3NB/RN4NB/RP3NB/RP4NB/GS3NB/GS4NB	◎	◎	×	◎
			GD3NA/GD4NA/SD3NA/SD4NA	◎	◎	×	◎
			GD3NB/GD4NB/SD3NB/SD4NB	◎	◎	×	◎
	RCA	Slider (Standard)	SA4C/SA5C/SA6C	◎	◎	×	◎
			SA4R/SA5R/SA6R	◎	◎	×	◎
		Slider (Motor Directly Linked)	SA4D/SA5D/SA6D/SS4D/SS5D/SS6D	◎	◎	×	◎
		Rod (Standard)	RA3C/RA4C/RA3D/RA4D/RA3R/RA4R	◎	◎	×	◎
			SRA4R	◎	◎	×	◎
		Rod (With Guide)	RGS3C/RGS4C/RGS3D/RGS4D/SRGS4R	◎	◎	×	◎
			RGD3C/RGD4C/RGD3D/RGD4D	◎	◎	×	◎
			RGD3R/RGD4R/SRGD4R	◎	◎	×	◎
		Arm	A4R/A5R/A6R	◎	◎	×	◎
		Absolute Type	All Models	◎	◎	×	◎
	RCACR	Slider (Standard)	SA4C/SA5C/SA6C	◎	◎	×	◎
		Slider (Motor Directly Linked)	SA5D/SA6D	◎	◎	×	◎
	RCAW	Rod	RA3C/RA3D/RA3R/RA4C/RA4D/RA4R	◎	◎	×	◎
	RCS4	Slider (Standard)	SA4C/SA6C/SA7C/SA8C SA4R/SA6R/SA7R/SA8R	◎	◎	×	◎
		Slider (Wide)	WSA10C/WSA12C/WSA14C/WSA16C WSA10R/WSA12R/WSA14R/WSA16R	◎	◎	×	◎
		Slider (High Stiffness)	HSA6C/HSA7C	◎	◎	×	◎
		Rod (Standard)	RA4C/RA6C/RA7C/RA8C RA4R/RA6R/RA7R/RA8R	◎	◎	×	◎
			RRA4C/RRA6C/RRA7C/RRA8C RRA4R/RRA6R/RRA7R/RRA8R	◎	◎	×	◎
		Rod (Radial Cylinder)	WRA10C/WRA12C/WRA14C/WRA16C WRA10R/WRA12R/WRA14R/WRA16R	◎	◎	×	◎
		Table	TA4C/TA6C/TA7C/TA4R/TA6R/TA7R	◎	◎	×	◎
	RCS4CR	Slider (Standard)	SA4C/SA6C/SA7C/SA8C	◎	◎	×	◎
		Slider (Wide)	WSA10C/WSA12C/WSA14C/WSA16C	◎	◎	×	◎
	RCS3	Slider (High-Speed)	CT8C	◎	◎	×	◎
		Rod (Servo Press)	RA4R	◎	○	×	◎
			RA6R/RA7R/RA8R/RA10R/RA15R/RA20R	◎	◎	×	◎
	Table (High-Speed)	CTZ5C	◎	◎	×	◎	
	RCS3 RCS3P	Slider	SA8C/SS8C	◎	○	×	◎
			SA8R/SS8R	◎	○	×	◎
	RCS3CR RCS3PCR	Slider	SA8C/SS8C	◎	○	×	◎
	RCS2	Slider (Standard)	SA4C/SA5C/SA6C/SA7C/SS7C/SS8C	◎	○	×	◎
			SA4R/SA5R/SA6R/SA7R/SS7R/SS8R	◎	○	×	◎
		Slider (Motor Directly Linked)	SA4D/SA5D/SA6D	◎	○	×	◎
		Rod (Standard)	RN5N/RP5N/RA4C/RA5C/RA4D/RA4R/RA5R	◎	○	×	◎
			SRA7BD	◎	×	×	◎
		Rod (Servo Press)	RA13R	◎	◎	×	◎
		Rod (With Guide)	GS5N/GD5N/SD5N	◎	○	×	◎
			RGS4C/RGS5C/RGS4D/RGD4C/RGD5C	◎	○	×	◎
			RGD4D/RGD4R	◎	○	×	◎
			SRGS7BD/SRGD7BD	◎	×	×	◎
		Table	TCA5N/TWA5N/TFA5N	◎	○	×	◎
		Arm	A4R/A5R/A6R	◎	○	×	◎
		Flat	F5D	◎	○	×	◎
		Gripper	GR8/GRKL	◎	○	×	◎
	Rotary	RT6/RT6R/RT7R/RTC8L/RTC8HL/RTC10L/ RTC12L	◎	○	×	◎	
	Absolute Type	All Models	◎	○	×	◎	

1.1 Overseas Standards Compliance List (Actuator)

◎ : Standard Complied / ○ : Option

△ : Complied Under Special Order / × : No Plan for Compliance

■Actuator

Product Genre	Series Name	Type	Model	Revised RoHS Directive	CE Marking Compliance	UL Standards Compliance	TSCA
ROBO Cylinder	RCS2CR	Slider (Standard)	SA4C/SA5C/SA6C/SA7C/SS7C/SS8C	◎	○	×	◎
		Slider (Motor Directly Linked)	SA5D/SA6D	◎	○	×	◎
		Rod	RN5NB/RP5NB/GS5NB/GD5NB/SD5NB	◎	×	×	◎
	RCS2W	Rod	RN5NB/RP5NB/GS5NB/GD5NB/SD5NB	◎	○	×	◎
			RA4C/RA4R/RA4D	◎	○	×	◎
Single Axis Robot	ISB ISPB	Standard	SXM/SXL/MXM/MXL/MXXM/ LXM/LXL/LXXM/LXUWX/WXM/WXXM	◎	◎	×	◎
	ISDB ISDPB	Simple Dustproof	S/M/MX/L/LX	◎	◎	×	◎
	ISDBCR ISDPBCR	Clean	S/M/MX/L/LX	◎	◎	×	◎
	SSPA	High Stiffness (Steel Base)	SXM/MXM/LXM	◎	◎	×	◎
	SSPDACR	Clean and High Stiffness (Steel Base)	S/M/L	◎	◎	×	◎
	ISA ISPA	Standard	SXM/SYM/SZM/MXM/MYM/MZM/MXXM/ LXM/LYM/LZM/LXXM/LXUWX/WXM/WXXM	◎	◎	×	◎
	ISDA ISPSA	Simple Dustproof	S/M/MX/L/LX	◎	◎	×	◎
	ISDACR ISPSACR	Clean	S/M/MX/L/LX/W/WX	◎	◎	×	◎
	ISWA ISPSWA	Dustproof/Splash Proof	S/M/L	◎	◎	×	◎
	NSA	Standard	MXMS/MXMM	◎	◎	×	◎
			LXMS/LXMM/LXMXS/LXMXM	◎	◎	×	◎
			WXMS/WXMM/WXMSX/WXMXM	◎	◎	×	◎
	NS	Standard	SXMSA/SXMSMA/SZMSA/SZMSMA	◎	◎	×	◎
			MXMSA/MXMSMA/MXMSXA/MZMSA/MZMSMA	◎	◎	×	◎
			LXMSA/LXMSMA/LXMSXA/LZMSA/LZMSMA	◎	◎	×	◎
	IF	Standard	SA*L/SA*R/MA*L/MA*R(*: 1 or 2 or 3)	◎	×	×	◎
	IFA	Standard	SA*L/SA*R/MA*L/MA*R(*: 1 or 2 or 3)	◎	◎	×	◎
RS	Rotary Axis	30/60	◎	×	×	◎	
ZR	Vertical/Rotation Integrated Type	S/M	◎	×	×	◎	
Direct Drive Motor	DDA	Standard	LT18□/LH18□	◎	◎	×	◎
	DDACR	Clean	LT18□/LH18□	◎	◎	×	◎
	DDW	Dustproof/Splash Proof	LH18C□	◎	◎	×	◎
Linear	RCL	Slider (Single-Slider)	SA1L/SA2L/SA3L/SA4L/SA5L/SA6L	◎	×	×	◎
		Slider (Multi-Slider)	SM4L/SM5L/SM6L	◎	×	×	◎
		Rod	RA1L/RA2L/RA3L	◎	×	×	◎
	LSA LSAS	Small	H	◎	×	×	◎
		Medium	N	◎	×	×	◎
		Large	W	◎	×	×	◎
		Shaft	S	◎	×	×	◎
Flat	L	◎	×	×	◎		
Orthogonal Robot	ICSA ICSPA	-	-	◎	×	×	◎
	ICSB ICSPB	-	-	◎	×	×	◎
	IK	-	-	◎	×	×	◎
6-axis Cartesian Robot	CRS	-	-	◎	×	×	◎
Table Top	TT	-	TT-A2/A3/C2/C3	×	×	×	×
	TTA	-	TTA-A2(G)/A3□(G)/A4□(G)/C2□(G)/C3□(G)/C4□(G)	◎	◎(*2)	×	◎

\*2 Dedicated for Safety Categories Complied Types.

1.1 Overseas Standards Compliance List (Actuator)

◎ : Standard Complied / ○ : Option

△ : Complied Under Special Order / × : No Plan for Compliance

■Actuator

Product Genre	Series Name	Type	Model	Revised RoHS Directive	CE Marking Compliance	UL Standards Compliance	TSCA
SCARA	IXA	Standard	3NNN1805/4NNN1805	◎	◎	×	◎
			3NNN3015/4NNN3015	◎	◎	×	◎
			3NNN45□□/4NNN45□□	◎	◎	×	◎
			3NNN60□□/4NNN60□□	◎	◎	×	◎
			4NNN80□□	◎	◎	×	◎
		4NNN100□□	◎	◎	×	◎	
		High-Speed	3NSN3015/4NSN3015	◎	◎	×	◎
			3NSN45□□/4NSN45□□	◎	◎	×	◎
			3NSN60□□/4NSN60□□	◎	◎	×	◎
			4NSN80□□	◎	◎	×	◎
			4NSN100□□	◎	◎	×	◎
		High Payload	4NHN10040/4NHN12040	◎	◎	×	◎
		High-Speed Type Clean Room Specifications	4NSC3015	◎	◎	×	◎
			4NSC45□□	◎	◎	×	◎
			4NSC60□□	◎	◎	×	◎
	Dustproof/Splash Proof	4NSW3015	◎	◎	×	◎	
		4NSW45□□	◎	◎	×	◎	
		4NSW60□□	◎	◎	×	◎	
		4NSW80□□/4NSW100□□	◎	◎	×	◎	
		4NHW12040	◎	◎	×	◎	
	IXP	Standard	3N1808/3N2508/4N1808/4N2508	◎	◎	×	◎
			3N3515/3N4515/4N3515/4N4515	◎	◎	×	◎
			3N5520/4N5520/3N6520/4N6520	◎	◎	×	◎
		With Gripper	3N1808GM/3N2508GM/3N3515GM/3N4515GM/3N3510GL/3N4510GL	◎	◎	×	◎
			3N5515GL/3N5515GW/3N6515GL/3N6515GW	◎	◎	×	◎
		Clean	3C3515/4C3515/3C4515/4C4515	◎	◎	×	◎
			3C5520/4C5520/3C6520/4C6520	◎	◎	×	◎
		Dustproof/Splash Proof	3W3515/4W3515/3W4515/4W4515	×	×	×	◎
			3W5520/4W5520/3W6520/4W6520	×	×	×	◎
	IX	Standard (NNN)	1205/1505/1805	◎	○	×	◎
			2515H/3515H	◎	○	×	◎
			50□□H/60□□H/70□□H/80□□H	◎	○	×	◎
		Clean/Dustproof/Splash Proof Ceiling-mount, High-Speed, Wall-mount	1205/1505/1805/2515H/3515H/3015H 50□□H/60□□H/70□□H/80□□H	◎	○	×	◎
Wrist Unit	WU	-	S/M	◎	◎	×	◎
Solenoid Gripper	GRS	-	SEG/MEG	◎	◎	×	◎
		-	SIG/MIG	◎	◎	×	◎
Other	Motor Unit	ISAC	200W/400W	◎	×	×	◎
		ISAC High Stiffness (T1)	60W(RS)/100W/150W	◎	×	×	◎

## 1.2 Overseas Standards Compliance List (Controller)

The controllers IAI that are applicable for the global standards are as shown in the table below.  
The data described in this manual is as June 2, 2025.

◎ : Standard Complied / ○ : Option

■ Controller

△ : Complied Under Special Order / × : No Plan for Compliance

Product Genre	Series Name	Type	Model	Revised RoHS Directive	CE Marking Compliance	UL Standards Compliance	TSCA	
Controller for ROBO Cylinder	MSEP	Incremental	C/LC	◎	◎	◎	◎	
		Simple Absolute	C-ABB/LC-ABB	◎	◎	◎	◎	
	MCON	–	C/CG/LC/LCG	◎	◎ <sup>(1)</sup>	◎	◎	
		Master Unit		RCON-GW/GWG	◎	◎	◎	◎
			RSEL-G	◎	◎	◎	◎	
			REC-GW	◎	◎	◎	◎	
	R-unit	Driver Unit		RCON-PC-1/RCON-PC-2	◎	◎	◎	◎
				RCON-PCF-1	◎	◎	◎	◎
				RCON-AC-1/RCON-AC-2	◎	◎	◎	◎
				RCON-DC-1/RCON-DC-2	◎	◎	◎	◎
			RCON-SC-1	◎	◎	◎	◎	
		Power Supply Unit	RCON-PS2-3	◎	◎	◎	◎	
		EC Connection Unit	RCON-EC-4	◎	◎	◎	◎	
		Simple Absolute Unitp		RCON-ABU-P	◎	◎	◎	◎
				RCON-ABU-A	◎	◎	◎	◎
		Expansion Unit		RCON-EXT	◎	◎	◎	◎
			RCON-EXT-NP/PN	◎	◎	◎	◎	
			RCON-NP/PN	◎	◎	◎	◎	
	e-Wiring System Connection Unit	RCON-EWS-16	◎	◎	×	◎		
	PCON	–	CB/CGB/CFB/CGFB	◎	◎ <sup>(2)</sup>	◎	◎	
		–	CBP/CGBP (dedicated for Pulse Press)	◎	◎ <sup>(2)</sup>	◎	◎	
		–	CA/CF/CFA	◎	◎ <sup>(3)</sup>	◎	◎	
		–	C/CG	◎	◎ <sup>(3)</sup>	◎	◎	
		–	CY/SE/PL/PO	◎	◎	◎	◎	
		–	CYB/PLB/POB	◎	◎	◎	◎	
	ACON	–	CB/CGB	◎	◎ <sup>(2)</sup>	◎	◎	
		–	CA	◎	◎ <sup>(3)</sup>	◎	◎	
		–	C/CG	◎	◎ <sup>(3)</sup>	◎	◎	
		–	CY/SE/PL/PO	◎	◎	◎	◎	
		–	CYB/PLB/POB	◎	◎	◎	◎	
	DCON	–	CB/CGB	◎	◎ <sup>(2)</sup>	◎	◎	
		–	CA	◎	◎ <sup>(3)</sup>	◎	◎	
		–	CYB/PLB/POB	◎	◎	◎	◎	
	SCON2	–	CG	◎	◎	◎	◎	
	SCON	–	CB/CGB/LC/LCG	◎	◎ <sup>(3)</sup>	◎ <sup>(4)</sup>	◎	
		–	CB-F (dedicated for Servo Press)/LC-F	◎	◎ <sup>(3)</sup>	◎ <sup>(4)</sup>	◎	
		–	CA	◎	◎ <sup>(3)</sup>	◎	◎	
		–	C	◎	◎	×	◎	
		–	CAL/CGAL	◎	◎ <sup>(3)</sup>	×	◎	
	MSCON	–	C	◎	◎	×	◎	
	RCM-P6	RCM-P6PC	–	◎	◎	◎	◎	
		RCM-P6AC	–	◎	◎	◎	◎	
		RCM-P6DC	–	◎	◎	◎	◎	

\*1 CC-Link IE in the field network is not complied.

\*2 CC-Link IE Field and MECHATROLINK-I/II in the field network are not complied.

\*3 MECHATROLINK-I/II in the field network are not complied.

\*4 3000 and 3300W types are not complied.

## 1.2 Overseas Standards Compliance List (Controller)

◎ : Standard Complied / ○ : Option

### ■ Controller

△ : Complied Under Special Order / × : No Plan for Compliance

Product Genre	Series Name	Type	Model	Revised RoHS Directive	CE Marking Compliance	UL Standards Compliance	TSCA		
Controllers for Single-Axis, Orthogonal Robot and SCARA Robots	PSEL	-	-	◎	◎	×	◎		
	ASEL	-	-	◎	◎	×	◎		
	SSEL	-	-	◎	◎	×	◎		
	MSEL	Standard	PC		◎	◎	×	◎	
		Safety Category Complied Type	PG		◎	◎	×	◎	
		56SP/60P/86P Motor Complied Type	PCF		◎	◎	×	◎	
		Safety Category Complied Type 56SP/60P/86P Motor Complied Type	PGF		◎	◎	×	◎	
	ROBONET	GatewayR Unit	RGW-DV/RGW-CC		◎	◎	◎	◎	
			RGW-PR/RGW-SIO		◎	◎	◎	◎	
		Controller Unit	RACON/RPCON		◎	◎	◎	◎	
		Simple Absolute R Unit	RABU		◎	◎	◎	◎	
		Expansion Unit	REXT		◎	◎	◎	◎	
		Expansion Unit (Unit Reversed) Expansion Unit (Controller Connection)	REXT-SIO REXT-CTL		◎	◎	◎	◎	
	MSEL	Standard	PCX3/PCX4		◎	×	×	◎	
		Safety Category Complied Type	PGX3/PGX4		◎	◎	×	◎	
	XSEL-RA/SA	Standard	RA/RAX/RAXD8		◎	◎	×	◎	
		Safety Category Complied Type	SA SAX/SAXD8		◎	◎	◎	◎	
	XSEL-R/S	Standard	R/RX/RXD8		×	×	×	×	
		Safety Category Complied Type	S/SX/SXD8		×	×	×	×	
	XSEL-P/Q	Standard	P		◎	◎	×	◎	
		Safety Category Complied Type	Q		◎	◎	◎	◎	
		SCARA	PX/QX		◎	◎	×	◎	
		CT4	PCT/QCT		◎	◎	◎	◎	
XSEL2	Safety Category Complied Type	TS/TL/TSX/TLX		◎	◎	*6	◎		
Driver Box	GRS	-	GRS-DB		◎	◎	×	◎	
Wire Controller	WC-EC	-	WC-EC		◎	◎	◎	◎	
Smart Web Unit	ICD	Smart Web Unit	ICD-CTU		◎	◎	×	*5	◎
		WLAN/Bluetooth Converter	ICD-WLBT		◎	×	×	*5	◎
		Ethernet/RS-485 Converter	ICD-ETSE		◎	◎	×	*5	◎

\*5 This product is not applicable.

\*6 XSEL2 is expected to obtain UL Standards.

## 1.3 Option

Options for our products that are applicable for the global standards are as shown in the table below.  
The data described in this manual is as June 2, 2025.

◎ : Standard Complied / ○ : Option

△ : Complied Under Special Order / × : No Plan for Compliance

### ■ Option

Product Genre	Series Name	Type	Model	Revised RoHS Directive	CE Marking Compliance	UL Standards Compliance	TSCA	
Teaching Pendant Tool	For Both Positioning Controller and Programming Controller	Standard	TB-01	◎	◎	×	◎	
			TB-02	◎	◎	×	◎	
		With Dead Man Switch	TB-01D/DR	◎	◎	×	◎	
			TB-02D	◎	◎	×	◎	
		Standard	TB-03	◎	◎	×	◎	
	Actuator Drive Power Unit	ADTB	◎	◎	×	◎		
	EC	Digital Speed Controller Teaching	TBD-1	◎	◎	×	◎	
		Remote Digital Speed Controller	TBD-1WL	◎	◎	×	◎	
	For EC (24V System) / RCP	Teaching Pendant Equipped with Power Supply Unit	TB-03E/03P	◎	◎	×	◎	
			TB-02E/02P	◎	◎	×	◎	
	RC System	General-Purpose Touch Panel Teaching Standard Type (Color LCD Type)	CON-PTA-C	◎	◎	×	◎	
			General-Purpose Touch Panel Teaching Enable Switch Equipped Type (Same as above)	CON-PDA-C	◎	◎	×	◎
			General-Purpose Touch Panel Teaching Safety Category Complied Type (Same as above)	CON-PGAS-C	◎	◎	×	◎
Quick Teaching	ERC3	RCM-PST	-	◎	×	×	◎	
MPG Cable	EC (200V Type)	Motor Cable	CB-EC-PW***-RB	◎	◎	×	◎	
	IXP/RCP6/RCP5/ RCP4-SA3·RA3/ RCP2/RCD	Motor/Encoder Integrated Cable	CB-CAN(2)-MPA	◎	◎	×	◎	
			CB-CAN(2)-MPA***-RB	◎	◎	×	◎	
			CB-ADPC(2)-MPA***	◎	◎	×	◎	
			CB-ADPC(2)-MPA***-RB	◎	◎	×	◎	
	RCP6/RCP5	Motor/Encoder Integrated Cable	CB-CFA3-MPA	◎	◎	×	◎	
	RCP4/RCD	Motor/Encoder Integrated Cable	CB-CA-MPA	◎	◎	×	◎	
			CB-CA-MPA***-RB	◎	◎	×	◎	
	RCP3/RCP2/ RCA2/RCA/RCL	Motor/Encoder Integrated Cable	CB-APSEP-MPA	◎	◎	×	◎	
			CB-RCAPC-MPA	◎	◎	×	◎	
			CB-RCAPC-MPA-RB	◎	◎	×	◎	
	RCP3/RCP2	Motor/Encoder Integrated Cable	CB-PCS-MPA	◎	◎	×	◎	
	RCP/RCP2	Motor/Encoder Integrated Cable	CB-PSEP-MPA	◎	◎	×	◎	
			Motor/Encoder Integrated Cable (Dedicated for Small Rotary)	CB-RPSEP-MPA	◎	◎	×	◎
			Motor Cable	CB-RCP2-MA	◎	◎	×	◎
		Encoder Cable	CB-RCP2-PB	◎	◎	×	◎	
			CB-RFA-PA	◎	◎	×	◎	
			CB-RCP2-PB***-RB	◎	◎	×	◎	
	CB-RFA-PA***-RB	◎	◎	×	◎			
	RCA2	Motor/Encoder Integrated Cable	CB-ACS-MPA	◎	◎	×	◎	
	RCA2/RCA/RCL	Motor/Encoder Integrated Cable	CB-ASEP-MPA	◎	×	×	◎	
			CB-ASEP2-MPA	◎	◎	×	◎	
		Motor Cable	CB-ACS-MA	◎	◎	×	◎	
			Encoder Cable	CB-ACS-PA	◎	◎	×	◎
	CB-ACS-PA***-RB	◎	◎	×	◎			
	RCS3-RA15R/20R	Motor Cable	CB-RCS3-MA***-RB	◎	◎	×	◎	
		Encoder Cable	CB-RCS3-PLA***-RB	◎	◎	×	◎	

◎ : Standard Complied / ○ : Option

△ : Complied Under Special Order / × : No Plan for Compliance

■ Option

Product Genre	Series Name	Type	Model	Revised RoHS Directive	CE Marking Compliance	UL Standards Compliance	TSCA
MPG Cable	RCS3/RCS2	Motor Cable	CB-RCC-MA	◎	◎	×	◎
			CB-RCC-MA***-RB	◎	◎	×	◎
		Encoder Cable	CB-RCS2-PA	◎	◎	×	◎
			CB-RCS2-PLA	◎	◎	×	◎
			CB-RCBC-PA	◎	◎	×	◎
			CB-RCS2-PLDA***(-RB)	◎	◎	×	◎
			CB-RCS2-PLLA (RA13R/Equipped with Loadcell)	◎	◎	×	◎
	CB-RCBC-PA***-RB	◎	◎	×	◎		
	XSEL	Motor Cable	CB-X-MA	◎	◎	×	◎
			CB-XMC-MA	◎	◎	×	◎
			CB-XEU-MA	◎	◎	×	◎
		Encoder Cable	CB-X-PA	◎	◎	×	◎
			CB-X1-PA/PLA	◎	◎	×	◎
			CB-X2-PA/PLA	◎	◎	×	◎
			CB-X1-PA***-WC	◎	◎	×	◎
	CB-X3-PA	◎	◎	×	◎		
	Limit switch Cable	CB-X-LC	◎	◎	×	◎	
	R-unit/SCON2	Motor Cable	CB-RCC1-MA***	◎	◎	×	◎
			CB-X2-MA***	◎	◎	×	◎
	Brake cable	IXA	-	CB-IXA-BK***	◎	◎	×
XSEL/XSEL2		External Brake Switch Connection Cable	CB-XRSA-BK***	◎	◎	×	◎
Power Supply/ I/O Cable	EC	PIO Type Power Supply	CB-EC-PWBIO***-RB	◎	◎	×	◎
			CB-EC2-PWBIO***-RB	◎	◎	×	◎
I/O Cable	MSEP	Standard	CB-MSEP-PIO	◎	◎	×	◎
		For LC	CB-PAC-PIO	◎	◎	×	◎
	PCON/ACON/DCON	For Standard (C/CA/CB/CG/CGB Type)	CB-PAC-PIO	◎	◎	×	◎
		For Solenoid Valve (CY Type)	CB-PACY-PIO	◎	◎	×	◎
		For Solenoid Valve (CYB Type)	CB-PAD-PIO	◎	◎	×	◎
		For Pulse Train Control (PL/PO Type)	CB-PACPU-PIO	◎	◎	×	◎
		For Pulse Train Control (PLB/POB Type)	CB-PAD-PIOS	◎	◎	×	◎
	SCON	For Standard	CB-PAC-PIO	◎	◎	×	◎
	MSEL	Standard	CB-PAC-PIO	◎	◎	×	◎
	PSEL/ASEL/SSEL	For Standard	CB-DS-PIO	◎	◎	×	◎
	XSEL/XSEL2	For Standard	CB-X-PIO	◎	◎	×	◎
	XSEL2	Standard SIO Communication Cable	CB-XSEL2-SIO***	◎	◎	×	◎
	ERC3	PIO Type Power Supply	CB-ERC3P-PWBIO	◎	◎	×	◎
		SIO Type Power Supply	CB-ERC3S-PWBIO	◎	◎	×	◎
	ERC/ERC2	PIO Type Power Supply	CB-ERC-PWBIO***(-RB)	◎	◎	×	◎
		Power & I/O Cable	CB-ERC-PWBIO***-H6	◎	◎	×	◎
CB-ERC-PWBIO***-RB-H6			◎	◎	×	◎	
SIO Type Power Supply	CB-ERC2-PWBIO***(-RB)	◎	◎	×	◎		
Communication cable for SIO	ERC3	-	CB-PST-SIO050	◎	◎	×	◎
Connection cable for RCON-EC	-	Standard Connector Cable	CB-REC-PWBIO***-RB	◎	◎	×	◎
		4-way Connector Cable	CB-REC2-PWBIO***-RB	◎	◎	×	◎
Other	EC	Interface Box Conversion Cable	CB-CVN-BJ002	◎	◎	×	◎
		Control Wire	CW-EC	◎	×	×	◎
	RCON/RSEL	Connection Cable for SCON	CB-RE-CTL***	◎	◎	×	◎
	RC System	PC Software	RCM-101-MW	◎	×	×	◎
			RCM-101-USB	◎	×	×	◎
			IA-OS-C	◎	×	×	◎
		External Communication Cable	CB-RCA-SIO***	◎	◎	×	◎
RS-232C Conversion Cable	RCB-CV-MW	◎	×	×	◎		

◎ : Standard Complied / ○ : Option

△ : Complied Under Special Order / × : No Plan for Compliance

## ■ Option

Product Genre	Series Name	Type	Model	Revised RoHS Directive	CE Marking Compliance	UL Standards Compliance	TSCA	
Other	RC System	USB Cable	CB-SEL-USB***	◎	◎	◎	◎	
		USB Conversion Adapter	RCB-CV-USB	◎	×	×	◎	
		Link Cable	CB-RCB-CTL***	◎	◎	×	◎	
		Unit Link Cable	CB-REXT-SIO***	◎	◎	×	◎	
		Controller Connection Cable	CB-REXT-CTL***	◎	◎	×	◎	
		TP Adapter to Controller Connection Cable	CB-CON-LB005	◎	◎	×	◎	
		Conversion Cable	CB-CAN-AJ002	◎	◎	×	◎	
		Conversion Connector	RCM-CV-APCS	◎	×	×	◎	
	SCON/SCON2	For CON-TG Adapter	RCB-LB-TGS	◎	◎	×	◎	
		Pulse Train Control Cable	CB-SC-PIOS	◎	◎	×	◎	
		I/O Cable for Safety Functional	CB-SC-STO030	◎	◎	×	◎	
	SCON2	Multifunction Connector Cable	CB-SC2-MFC***	◎	◎	×	◎	
	RCP6S	Connection Cable (between axes and GW)	CB-RCP6S-PWBIO□□□(-RB)	◎	◎	×	◎	
		Connection Cable (between hubs and GW)	CB-RCP6S-RLY□□□(-RB)	◎	◎	×	◎	
	ERC2	For PC Connection Cable	CB-ERC2-SIO***	◎	◎	×	◎	
		For Network Connection Cable	CB-ERC2-CTL***	◎	◎	×	◎	
	MSEL (Enclosed in this MSEL-ABB)	Connection Cable	CB-MSEL-AB***	◎	◎	×	◎	
	XSEL2	Motor Connector Conversion Unit	IA-CV-MOT	◎	×	×	◎	
		Cable for Motor Connector Conversion Unit	CB-XT4-MJ005	◎	×	×	◎	
	SEL System	PC Software (Cable + EMG BOX)	IA-101-X-MW	◎	×	×	◎	
			IA-101-XA-MW	◎	×	×	◎	
			IA-101-XA-USBMW-JS	◎	◎	×	◎	
			IA-101-X-USBS	◎	×	×	◎	
			IA-101-X-USBMW	◎	×	×	◎	
		PC Connection Cable (Single Item)	EMG SW BOX	◎	×	×	◎	
			CB-ST-E1MW***	◎	◎	×	◎	
			CB-ST-A2MW***	◎	◎	×	◎	
		USB Conversion Cable	CB-SEL-USB***	◎	◎	×	◎	
			IA-CV-USB	◎	×	×	◎	
			For SEL-TG Adapter	IA-LB-TGS	◎	◎	×	◎
			Joint Cable	CB-ST-232J001/CB-ST-422J010	◎	◎	×	◎
			SEL-TG Connection Cable	CB-SEL25-LBS***	◎	◎	×	◎
			Cable Between Brake Box and Controller	CB-XBB-PA030/050-CS	◎	◎	×	◎
			Brake Box Release Switch Cable	CB-XBB-SW020	◎	◎	×	◎
	Connection Cable (enclosed in EIOU-4)	CB-RS-IAN020	◎	×	×	◎		
	A/P/SSEL	SEL-TG Connection Cable	CB-SEL26H-LBS***	◎	◎	×	◎	
	DDA	Brake Box and Mechanical Connection Cable	CB-DDB-BK***	◎	◎	×	◎	
	SEL System	Panel Unit	PU-1	◎	×	×	◎	
		Connector Conversion Cable	CB-SEL-SJS***	◎	◎	×	◎	
	TTA	PC Software	IA-101-TTA-USB	◎	×	×	◎	
	On-Site Power Supply Unit	e-Wiring System	On-Site Power Supply Unit	EWS-OPS/OPSW	◎	◎	◎	◎
			Pressure welding connector	EWS-CN-C-05	◎	×(*3)	◎	◎
			Flat cable	CB-EWS-FL***-05/ CB-EWS-FLN***-05	◎	◎	×	◎
			EC connection cable	CB-EWS-EC***-05/ CB-EWS-ECW***-05	◎	◎	×	◎
			Small EC Connection Cable	CB-EWS-BJ***-05	◎	◎	×	◎
	Simple Absolute Unit	PCON/ACON	PCON-ABU/ACON-ABU	-	×	◎	×	
	Simple Absolute Battery Unit	ACON-CB/CGB	SEP-ABU/ABUS	-	◎	◎	×	
	24V DC Power Supply	-	PSA-24(L)	-	◎	◎	◎	◎
			PS-241/PS-242	-	×	×	×	◎
	DC Power Supply for EC Motor Drive	-	PSA-200	-	◎	◎	◎	◎

◎ : Standard Complied / ○ : Option

△ : Complied Under Special Order / / × : No Plan for Compliance

■ Option

Product Genre	Series Name	Type	Model	Revised RoHS Directive	CE Marking Compliance	UL Standards Compliance	TSCA			
PLC Connection Unit	RCP6S	RCB-P6PLC	-	◎	◎	◎	◎			
Hub Unit	RCP6S	RCM-P6HUB	-	◎	◎	◎	◎			
Gateway Unit	RCP6S	RCM-P6GW	-	◎	◎	◎	◎			
	ERC3	RCM-EGW	-	◎	×	×	◎			
RC Gateway (Communication Port Connection Dedicated Cable)	XSEL-P/Q	Communication Cable	CB-RCB-SIO***	◎	◎	×	◎			
	XSEL-R/S	Controller Link Cable	CB-RCB-CTL***	◎	◎	×	◎			
Expansion I/O Unit	SSEL	EIOU-1	-	◎	×	×	◎			
	MSEL						◎			
	TTA						◎			
	XSEL	EIOU-4	-	◎	×	×	◎			
Regenerative Resistor Unit	EC200V Type	RESU-1 RESUD-1	-	◎	◎	×	◎			
	R-unit (RCON-PS2-3)						◎			
	SCON2/SCON						◎			
	MSCON						◎			
	SSEL						◎			
	XSEL	◎								
	R-unit (RCON-PS2-3)	RESU-2 RESUD-2	-	◎	◎	×	◎			
	SCON2/SCON						◎			
	MSCON						◎			
	SSEL						◎			
	SCON (For RCS3-RA20R)	RESU-35T	-	◎	◎	×	◎			
SCON/SSEL	REU-2	-	◎	×	×	◎				
MSEP/MCON	RER-1	-	◎	×	×	◎				
Functional Safety Unit	SU	SU-S	-	◎	◎	◎	◎			
Absolute Battery	RCS-C/ECON	AB-1	-	(*1)	◎(*2)	×	◎			
	IX SCARA (For 250 to 800)	AB-3	-				◎			
	RCP2	AB-4	-				◎			
	XSEL-P/Q/R/S/RA/SA	AB-5	-				◎	◎	×	◎
	ASEL									◎
	ACON									◎
	SCON									◎
	MSCON									◎
	SSEL	◎								
	IX SCARA (For 120 to 180)	AB-6	-				◎	◎	×	◎
	PCON-ABU	AB-7	-				◎	◎	×	◎
	ACON-ABU									◎
	MCON									◎
MSEL	◎									
Driving Battery	TBD-1WL (REMOTE DIGITAL SPEED CONTROLLER)	AB-8	-	◎	◎	×	◎			
Absolute Battery Box	MSEP	MSEP-ABB	-	◎	◎	×	◎			
	MCON						◎			
	MSEL	MSEL-ABB	-	◎	◎	×	◎			
Dummy Plug	XSEL	DP-2	-	◎	◎	×	◎			
	PSEL	DP-4S	-	◎	◎	×	◎			
	ASEL						◎			
	SSEL						◎			
	MSEL						◎			

\*1 As it is complied with EU Batteries Directive (2006/66/E), it is not complied with RoHS Directive.

\*2 It is an option complied with EU Battery Regulation (2023/1542).

\*3 This product is not applicable.

◎ : Standard Complied / ○ : Option

△ : Complied Under Special Order / × : No Plan for Compliance

## ■Option

Product Genre	Series Name	Type	Model	Revised RoHS Directive	CE Marking Compliance	UL Standards Compliance	TSCA	
Dummy Plug	MCON	DP-5	-	◎	◎	×	◎	
	ACON-CGB						◎	
	DCON-CGB						◎	
	SCON-CGB/ CGBL/CAL						◎	
	RCON-SC/ SCON2/XSEL2	DP-6	-	◎	◎	×	◎	
Brake Release Box	-	BKR-01	-	◎	×	×	◎	
Brake Box	RCS2-RA13R	RCB-110-RA13-0	-	◎	×	×	◎	
	RCL	RCB-110-RCLB-0	-	◎	×	×	◎	
	DDA	IA-110-DD-4	-	◎	◎	×	◎	
Driver PC Board	MSEP (For Pulse Motor)	MSEP-PPD1/PD1/PD2	-	◎	×	×	◎	
	MSEP (For AC Servo Motor)	MSEP-AD1/AD2	-	◎	×	×	◎	
	MSEP (For DC Brush-less Motor)	MSEP-DD1/DD2	-	◎	×	×	◎	
	MCON (For Pulse Motor)	MCON-PPD1/PD1/PD2	-	◎	×	×	◎	
	MCON (For AC Servo Motor)	MCON-AD1/AD2	-	◎	×	×	◎	
	MCON (For DC Brush-less Motor)	MCON-DD1/DD2	-	◎	×	×	◎	
Fan unit	RCON	RCON-FU	-	◎	×	×	◎	
		RCON-FUH	-	◎	×	×	◎	
	PCON	PCON-FU	-	◎	×	×	◎	
	MSEP	MSEP-FU	-	◎	×	×	◎	
	MSCON	MSCON-FU	-	◎	×	×	◎	
	SCON2	SCON2-FU	-	◎	×	×	◎	
	SCON	SCON-FU	-	◎	×	×	◎	
	XSEL2	For Small Housing (TS/TSX)	UT-XSEL2-FNS	-	◎	×	×	◎
		For Big Housing (TL/TLX)	UT-XSEL2-FNL	-	◎	×	×	◎
PSA-24L	PSA-FU	-	◎	×	×	◎		
PIO Converter	ERC3	RCB-CV	-	◎	×	×	◎	
PIO Terminal Block	-	RCB-TU-PIO-A/B	-	◎	×	×	◎	
SIO Converter	-	RCB-TU-SIO-A/B	-	◎	×	×	◎	
RS-232 Conversion Unit	RCS	-	RCB-CV-MW	◎	×	×	◎	
	XSEL	RCB-CV-GW	-	◎	×	×	◎	
Pulse Converter	ACON/SCON	AK-04	-	◎	×	×	◎	
	SCON-CB	JM-08	-	◎	×	×	◎	
SIO Isolator	-	-	RCB-ISL-SIO	×	×	×	×	



# Overseas Standards Compliance Manual

---

## Chapter 2

# CE Marking

2.1	About CE Marking .....	2-1
2.2	Compliance Standards .....	2-3
2.3	Details of Caution Labels Attached on Devices .....	2-5
2.4	Environment .....	2-7
	2.4.1 Operating Environment .....	2-7
	2.4.2 Installation Environment .....	2-10
	2.4.3 Storage Environment .....	2-11
2.5	Space Required for Actuator Maintenance Inspection (Unit: mm) .....	2-12
2.6	Power Supply .....	2-18
2.7	Grounding .....	2-19
2.8	Construction of Peripheral Devices and Applicable Units ..	2-20
	2.8.1 ROBONET-RGW .....	2-23
	2.8.2 MSEP-C/LC, MCON-C/CG, MCON-LC/LCG .....	2-25
	2.8.3 PMEC-C (200V AC Power Supply Type) .....	2-27

2.8.4	ACON-C/CG/CY/PL/PO/SE/CA/CB/CGB/CYB/PLB/POB, DCON-CA/CB/CGB/CYB/PLB/POB, ASEP-C/CW, DSEP-C/CW .....	2-29
2.8.5	PCON-C/CG/CY/PL/PO/SE/CA/CB/CGB/CBP/CGBP/CYB/ PLB/POB, RCP2-C/CF, PSEP-C/CW .....	2-31
2.8.6	ASEL-C/CS, PSEL-C/CS .....	2-33
2.8.7	SCON-C/CA/CAL/CGAL/CB/CGB/LC/LCGB SCON-CGB-F (for 3000W and 3300W motors) .....	2-35
2.8.8	SCON2-CG .....	2-37
2.8.9	MSCON-C .....	2-39
2.8.10	SSEL-C/CS .....	2-41
2.8.11	XSEL2 .....	2-43
2.8.12	XSEL-P/RA .....	2-46
2.8.13	XSEL-Q/SA .....	2-49
2.8.14	XSEL-PX/RAX/RAXD .....	2-52
2.8.15	XSEL-QX/SAX/SAXD .....	2-56
2.8.16	TTA 2-61	
2.8.17	ERC/ERC2/ERC3 .....	2-62
2.8.18	MSEL-PC/PG/PCF/PGF .....	2-64
2.8.19	MSEL-PGX .....	2-66
2.8.20	RCON-GW/GWG .....	2-68
2.8.21	RSEL-G .....	2-70
2.8.22	RCON-SC .....	2-72
2.8.23	REC 2-74	
2.8.24	ELECYLINDER .....	2-75
2.8.25	ELECYLINDER 200V .....	2-77
2.8.26	ROBO PUMP .....	2-78
2.8.27	On-Site Power Supply Unit .....	2-79
2.8.28	e-Wiring System Connection Unit .....	2-80
2.9	Components for EMC Counteraction .....	2-82
2.9.1	Clamp Filter .....	2-82
2.9.2	Ring Core .....	2-84
2.9.3	Noise Filter .....	2-85
2.9.4	Surge Protector .....	2-95
2.9.5	24V DC Power Supply .....	2-98
2.10	Protection Equipment to Ensure Safety .....	2-101
2.10.1	No Fuse Breaker (Circuit Breaker) .....	2-101
2.10.2	Leakage Breaker .....	2-103
2.10.3	Contactator .....	2-104
2.10.4	Safety Relay .....	2-105
2.10.5	Fuse .....	2-106

## 2.1 About CE Marking

Display of CE Mark is compulsory for the specified products distributed in the areas of European Union (EU). The products with CE mark displayed on them are guaranteed for free sales and trade within the EU market.

The CE Marking declares that a product meets the compulsory safety requirements given in EU (EC) Directives, and the manufacturer is to display it on his product on his sole responsibility. As the compulsory safety requirements, “EMC Directive”, “Low Voltage Directive” and “Machinery Directive” were prescribed under the adoption of New Approach Directives in 1985, and these directives prescribe the compulsory requirements that each product should follow and define the EN standards to be embodied.

The application status of IAI products is as shown in [Chapter 1 Overseas Standards Compliance List] described in this manual.

Please note that there are some products that require an appropriate action to be taken such like connecting to peripheral devices to comply with the standard.

### [1] EMC Directive

It is a directive related to products that radiates electromagnetic wave or that the features may get affected by external electromagnetic wave.

There are design requests not to radiate strong electromagnetic wave externally or get affected by external electromagnetic wave.

IAI products satisfy the standards related to EMC Directive by themselves under the condition that the controller, actuator and the wiring layout and attachment of other peripheral devices are determined.

### [2] Low Voltage Directive

It is a directive about safety of electric appliances that drive with power source of 50 to 1000V AC or 75 to 1500V DC.

Some actuators models for RCS2/RCS3/RCS4/IF/IFA/FS/RS, ISA/ISPA, ISB/ISPB, ISDA/ISPDA, ISDB/ISPDB, ISDACR/ISPDACR, ISDBCR/ISPDBCR, ISWA/ISPWA, NS/NSA, SSPA, DD/DDA, DDW, DDCR/DDACR EC200V AC Servo motor actuators are designed to comply with the Low Voltage Directive under a combination with the controller. (EC200V AC Servo motor is integrated with controller)

24V related ROBO CYLINDER does not comply with this directive.

### [3] Machinery Directive

It is a directive about safety mainly for industrial machineries but also for general products with a risk confirmed at movable parts that machinery products have to satisfy.

IX/IXP (Dustproof/Splash Proof to be excluded) /IXA and TTA Series actuators comply with the Machinery Directive. Other IAI products do not comply with the Machinery Directive.

However, although some products are declared as “semi-finished products”, this does not guarantee that your equipment complies with EC (EU) Directive.

The customer must verify the conformity of the equipment with the EU (EC) Directives before the customer completes the equipment with our products and ships it as a final product within Europe or uses it within Europe.

### [4] RoHS3 Directive

This is an EU (EC) directive to which our products are subject and which requires that the specified contained substances be kept below the specified values.

The models and some of the options (cables, etc.) that are with the EC declaration of conformity in [1] and [2] above are all complied with directive.

## 2.2 Compliance Standards

Refer to EC Declaration of Conformity of each model for the compliant standards.

### <EMC Directive>

EMC Directive: 2014/30/EU

EN55011: 2016/A1: 2017/A11: 2020

(Industrial, scientific and medical(ISM) radio-frequency equipment-Electromagnetic disturbance characteristics)

EN61000-6-2: 2005/AC: 2005 <sup>(\*1)</sup> (Immunity standard for industrial environments)

EN61800-3: 2004/A1: 2012 (EMC requirements and test conditions)

EN61000-3-2: 2014 (Method of emission tests for harmonics)

EN61000-3-3: 2013 (Method of emission tests for voltage variations)

\*1 Listed below are the standards that EN61000-6-2 : 2005/AC : 2005 refers to.

EN61000-4-2 (Electrostatic discharge immunity test)

EN61000-4-3 (Radiated, radio-frequency, electromagnetic field immunity test)

EN61000-4-4 (Electrical fast transient/burst immunity test)

EN61000-4-5 (Surge immunity tests)

EN61000-4-6 (RF conducted disturbances immunity test)

EN61000-4-8 (Power frequency magnetic field immunity test)

EN61000-4-11 (Immunity tests for voltage dips, short interruptions and voltage variations)

### <Low Voltage Directive>

Low Voltage Directive: 2014/35/EU

EN61800-5-1: 2007 (Variable-speed driving system)

### <Machinery Directive>

Machinery Directive: 2006/42/EC

EN ISO 12100: 2010 (Safety of machinery, Basic terminology, methodology, Technical principles, Risk assessment)

EN ISO 10218-1: 2011 <sup>(\*2)</sup> (Safety requirements – Part 1: Robots for industrial environment)

\*2 Listed below is the standard that EN ISO10218-1 : 2011 refers to.

EN ISO 13849-1: 2006 (General principles for design for safety of machinery and safety-related parts of control systems)

### <RoHS3 Directive>

RoHS3 Directive: 2011/65/EU+ (EU) 2015/863

EN IEC 63000: 2018 (Technical documentation for the assessment of electrical and electronic products with respect to the restriction of hazardous substances)

### <Wireless Devices Directive>

Radio equipment directive: 2014/53/EU

EN55032: 2015 (Electromagnetic compatibility of multimedia equipment - Emission Requirements)

ESTI EN 300 328 V2.2.2

## 2.3 Details of Caution Labels Attached on Devices

Some labels as shown below may be attached on the actuator that you have purchased. For those models with these labels, please comprehend the meanings of the labels and pay attention so the product can be handled safely.

[1] Electric Shock Caution Label



### **Electric Shock Caution**

This model contains high voltage in the live parts. Make sure to turn the power OFF before disconnecting a connector for service and maintenance to avoid electric shock.

[2] High Temperature Caution Label



### **High Temperature Caution**

This model may generate heat during its operation. Make sure to leave it for enough time before providing a service or maintenance to avoid a burn.

[3] Pinching Caution Label



### **Pinching Caution**

Do not attempt to touch moving parts of the rod or slider while it is moving. Your hand may get caught and injured.

[4] Hitting Caution Label



### **Hitting Caution**

Do not get close to the actuator while it is moving. The rod or slider may touch and may cause injury.

[5]-1 Vertical Mount Caution Label



**Vertical Mount Caution**

The moving part may drop when the servo or power is turned off if this model is mounted in vertical orientation.

[5]-2 Holding Area Caution Label



**Holding Area Caution**

When transporting this model, make sure to hold the base area, not the motor cover. Doing so may damage and drop the product and may cause an injury since it is a high-weighted product.

[5]-3 High Weight Transportation Caution Label



**High Weight Transportation Caution**

This model has high weight over 20kgs. Make sure to transport the product with 2 or more persons since it may hurt your back if you carry it only with one person.

[6] Strong Magnetic Field Caution Label



**Strong Magnetic Field Caution**

This model leaks relatively big magnetic flux compared to other models for the constructional reasons. Do not get closer than 50cm if you are a person who needs a support of a medical device such as a pacemaker since the magnetic flux leakage may give an influence to your device.

## 2.4 Environment

### 2.4.1 Operating Environment

The CE compliance products of IAI can be used under the conditions shown in the table below:

Item	Actuator Standard	Controller Standard	Applicable Standard
Overvoltage Category <sup>(*1)</sup>	II	II or III	IEC 60364-4-44: 2007
Pollution Degree <sup>(*2)</sup>	2 or 3	2	IEC 60664-1: 2007
IP Code	IP67 to IP20 <sup>(*4)</sup>	IP20	IEC 60529: 2001
Appliance Class <sup>(*3)</sup>	I	I	IEC 60335-1: 2001
Altitude	1000m or less	1000m or less	—
Ambient Temperature Range	0 to 40°C	0 to 40°C	—
Ambient humidity Range	Max85% (Not suitable in condensation)	Max85% (Not suitable in condensation)	—

\*1 Overvoltage Category:

It is also expressed as “Installation Category”, and identifies the performance of the voltage durability against the impulse voltage (transitional excess voltage) that a wiring system or electrical equipment connected to the AC power source can stand.

Nominal Voltage of Power Supply [V]		Necessary Impulse Voltage Durability [V]	
3-phase	Split-phase	Overvoltage Category	
		III	II
—	120-240	2500	1500
230/400	—	4000	2500
400/690	—	6000	4000

\*2 Pollution Degree:

The surrounding environment may often be a cause of pollution to the insulation performance. Solid particles, dust, liquid (water) or vapor (gas) can cause short-circuit, degradation in insulation or change in resistance. There is also a case the humidity makes the machine's conductivity. Such environmental condition is categorized and specified into several degrees.

Pollution Degree 2 ... Environment that may cause non-conductive pollution or transient conductive pollution by frost. It is the environmental level in control panel.

Pollution Degree 3 ... Environment that may cause conductive pollution or cause the conductivity by condensing dry non-conductive pollution. It is the environmental level in an averaged factory.

## \*3 Appliance Class: Categorization related to protection against electric shock

Appliance Class I ... These are the appliances that have an additional safety measure, not relying only on the basic insulation for electrical shock protection, by connecting the ground to the electrical protection grounding conductor on the main cables of the facility so the touchable conductive part would not become a live conductor in the case the basic insulation is failed. In short, they are the electrical appliances with grounding connection required as a compulsory.

## \*4 IP Code:

Solid Particle Protection	
IP0X	No Protection
IP1X	No ingress of solid particle over $\varnothing 50\text{mm}$
IP2X	No ingress of solid particle over $\varnothing 12.5\text{mm}$
IP3X	No ingress of solid particle over $\varnothing 2.5\text{mm}$
IP4X	No ingress of solid particle over $\varnothing 1\text{mm}$
IP5X	Ingress of dust is not entirely prevented, but it must not enter in sufficient quantity to interfere with the satisfactory operation of the equipment
IP6X	No ingress of dust; complete protection against contact

Liquid Ingress Protection	
IPX0	No Protection
IPX1	Vertically falling drops of water shall have no harmful effect
IPX2	Vertically dripping water shall have no harmful effect when the enclosure is tilted at an angle up to 15deg from its normal position
IPX3	Water falling as a spray at any angle up to 60deg from the vertical shall have no harmful effect
IPX4	Water splashing against the enclosure from any direction shall have no harmful effect
IPX5	Water projected against enclosure from any direction shall have no harmful effects
IPX6	Water projected in powerful jets against the enclosure from any direction shall have no harmful effects
IPX7	Ingress of water in harmful quantity shall not be possible when the enclosure is immersed in water under defined conditions of pressure and time
IPX8	No ingress of water inside enclosure shall occur after continuous immersion in water

[Complying with Low Voltage Directive Demands]

For a 200V type actuator (models subject to Low Voltage Directive), in order to comply with the demands for the Low Voltage Directive, it is necessary to have the connector covers clamp with a zip ties at a point that the connector covers are overlapped with each other after establishing connectivity of the connectors on the motor cable and encoder cable with connectors on the relay cables and overlap a connector cover to another.

Clamp the connectors again after the work when a connector is unplugged for such reason as maintenance.

\* The applicable models are described in [2.1 About CE Marking [2] Low Voltage Directive]

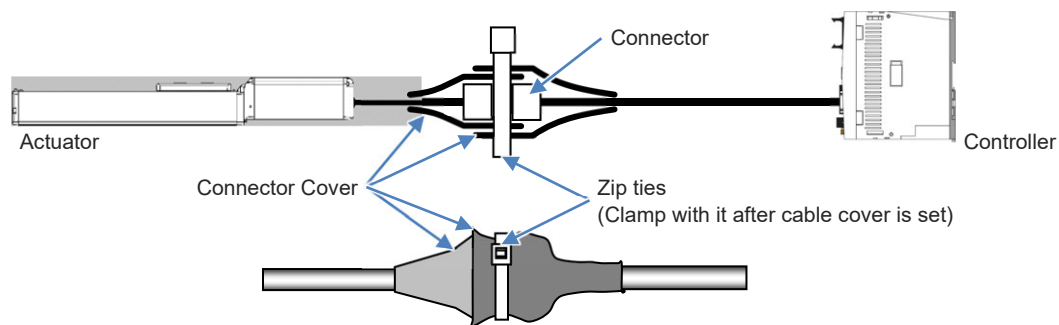

### 2.4.2 Installation Environment

---

#### a) Installation environment of the actuator

- There should be no direct sunlight.
- Any radiant heat from a large heat source such as a heat treatment furnace should not be directed at the machine main body.
- There should be no corrosive gas or flammable gas.
- It should be a normal assembling work environment where there is not too much dust.
- Oil mist or cutting liquid should not be directed at the machine.
- An impact or vibration should not be transmitted to it.
- There should be no strong electromagnetic waves, ultraviolet rays or radiation.
- Chemical resistance specification is not considered to this product.

It is generally the environment where a worker can work without any protection gear.

#### b) Installation environment of the controller

- It should be installed in a control panel that possesses a structure that would not let in water, oil, carbon or dust (IP54).

### 2.4.3 Storage Environment

---

Storage environment is basically the same as the use and installed environments. However, prevent an environment that would cause condensation for a long-term storage.

Unless specially specified, moisture absorbency protection is not included in the package when the machine is delivered. In the case that the machine is to be stored in an environment where dew condensation is anticipated, take the condensation preventive measures from outside of the entire package, or directly after opening the package.

For storage temperature, the machine withstands temperatures up to 60°C for a short time, but in the case of the storage period of 1 month or more, control the temperature to 50°C or less.

## 2.5 Space Required for Actuator Maintenance Inspection (Unit: mm)

For the models not shown in the pictures below, please contact us.

a) RCA2-SA2AC

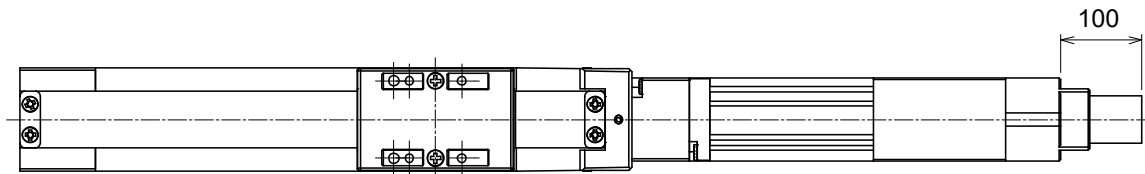

b) RCA2-SA2AR

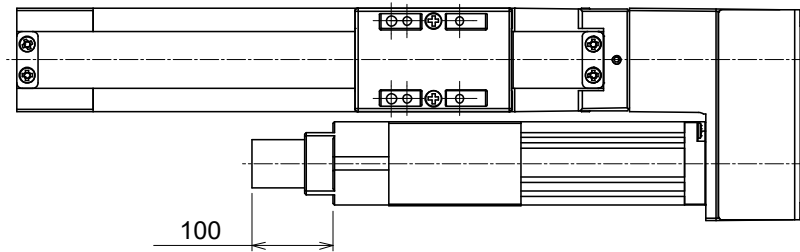

c) RCA2-RA2AC

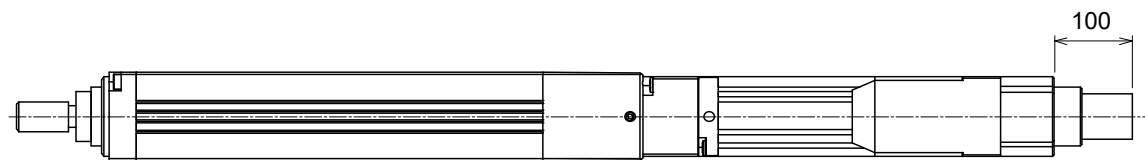

d) RCA2-RA2AR



e) RCA/RCP2-SRA4R

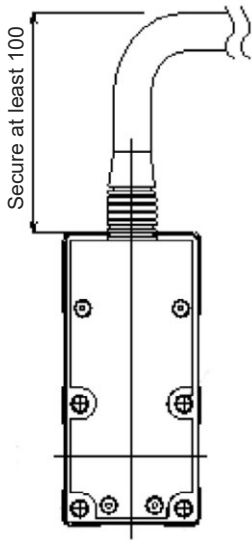

f) RCA/RCP2-SRGS4R

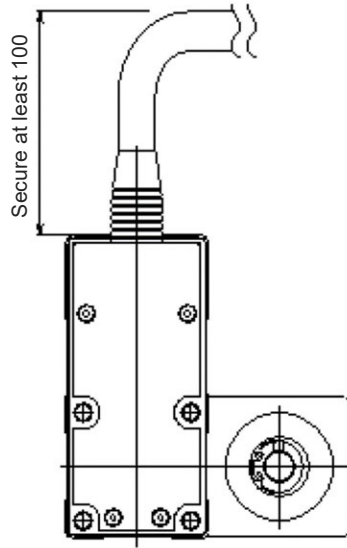

g) RCA/RCP2-SRGD4R

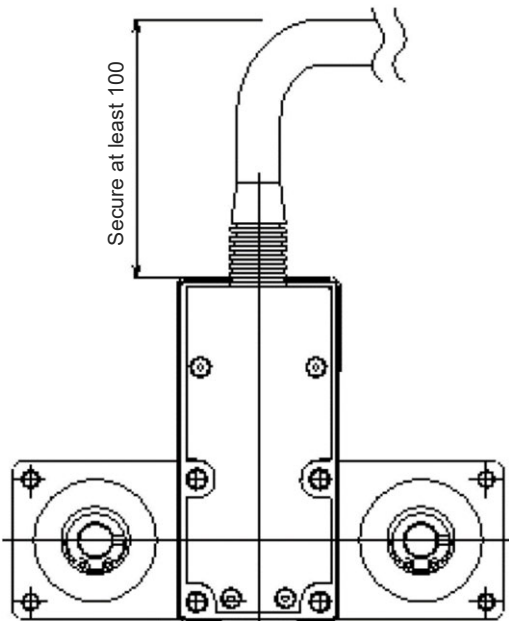

h) RCP2-GRSS (Same for other gripper type actuators)

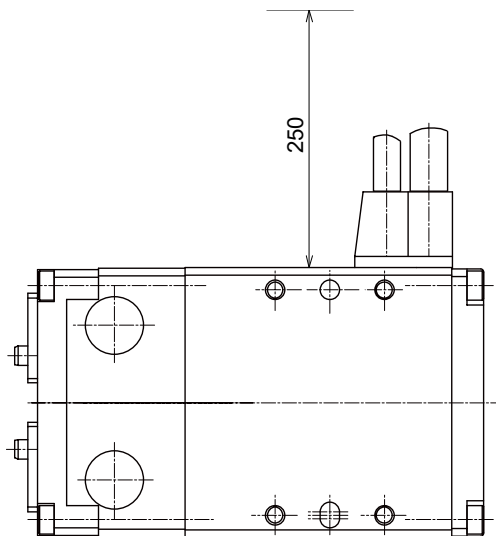

i) RCP2-RTB  
(Same for other rotary type actuators)

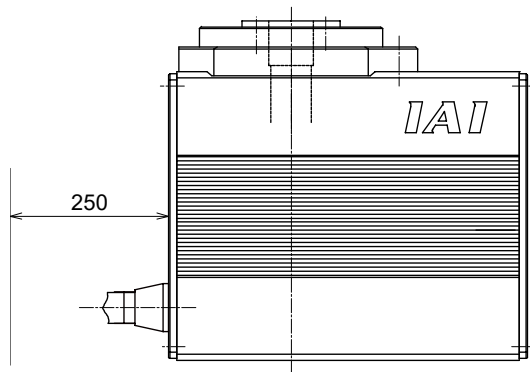

j) RCP2-SRA4R  
(Same for other short type actuators)

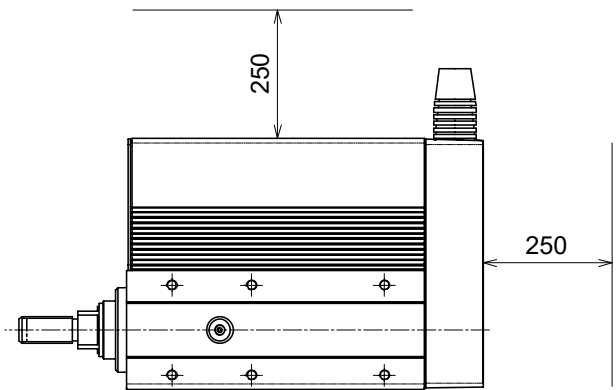

k) Rod Type (Those except for above, including ERC2)

[Motor Straight Type]

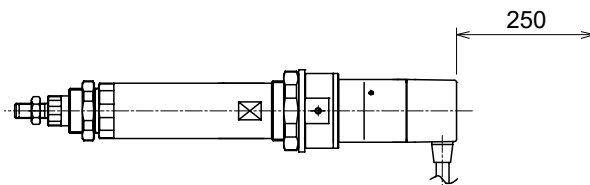

[Motor Reversing Type]

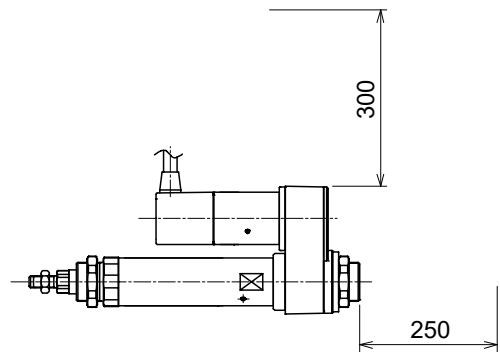

l) Slider Type (Those except for above, including ERC2)

[Motor Straight Type]

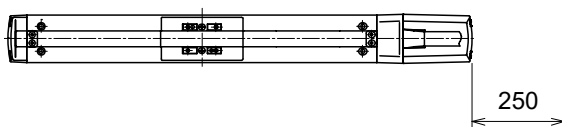

[Motor Reversing Type]

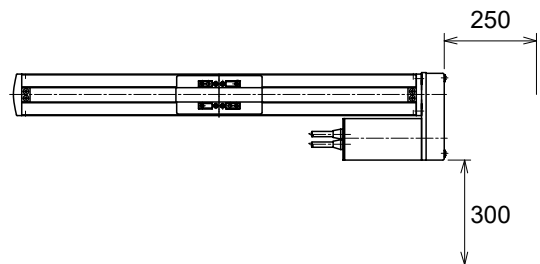

m) Slider Belt Type

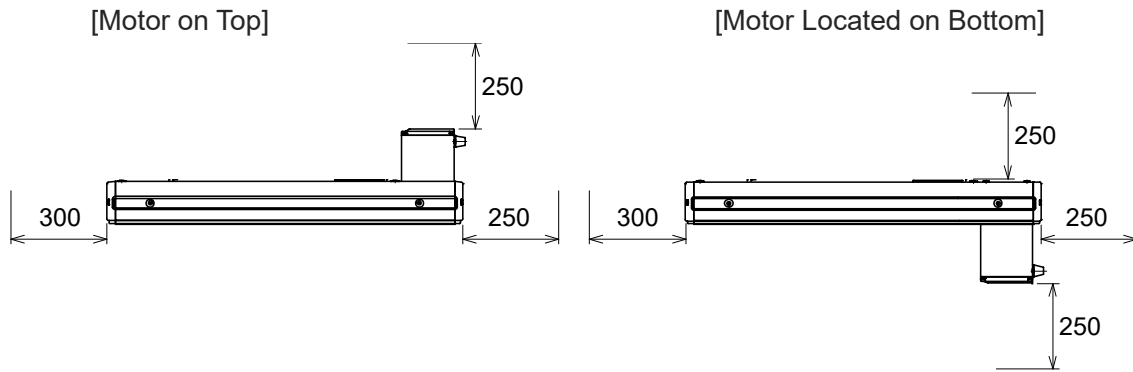

n) ISA-LX\* (Same for other IS Series models)

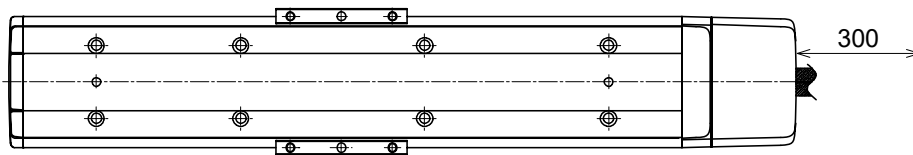

o) IF/IFA Series

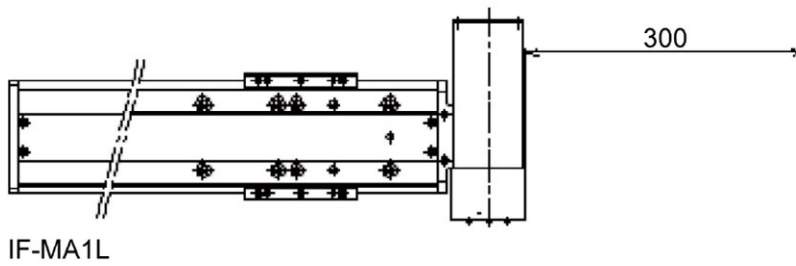

p) FS Series

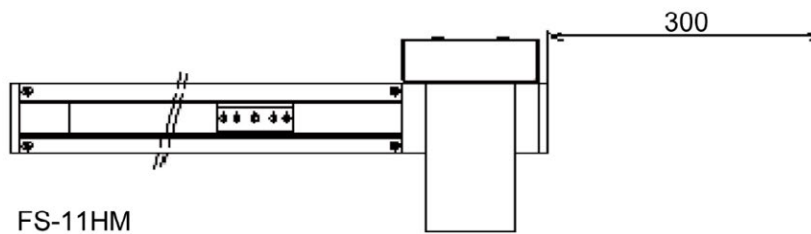

q) RS Series

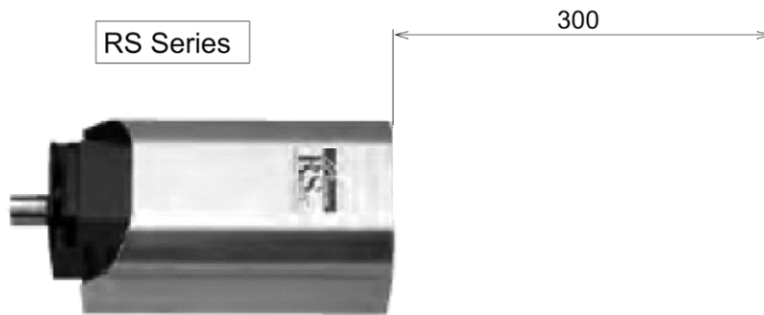

r) TTA Series

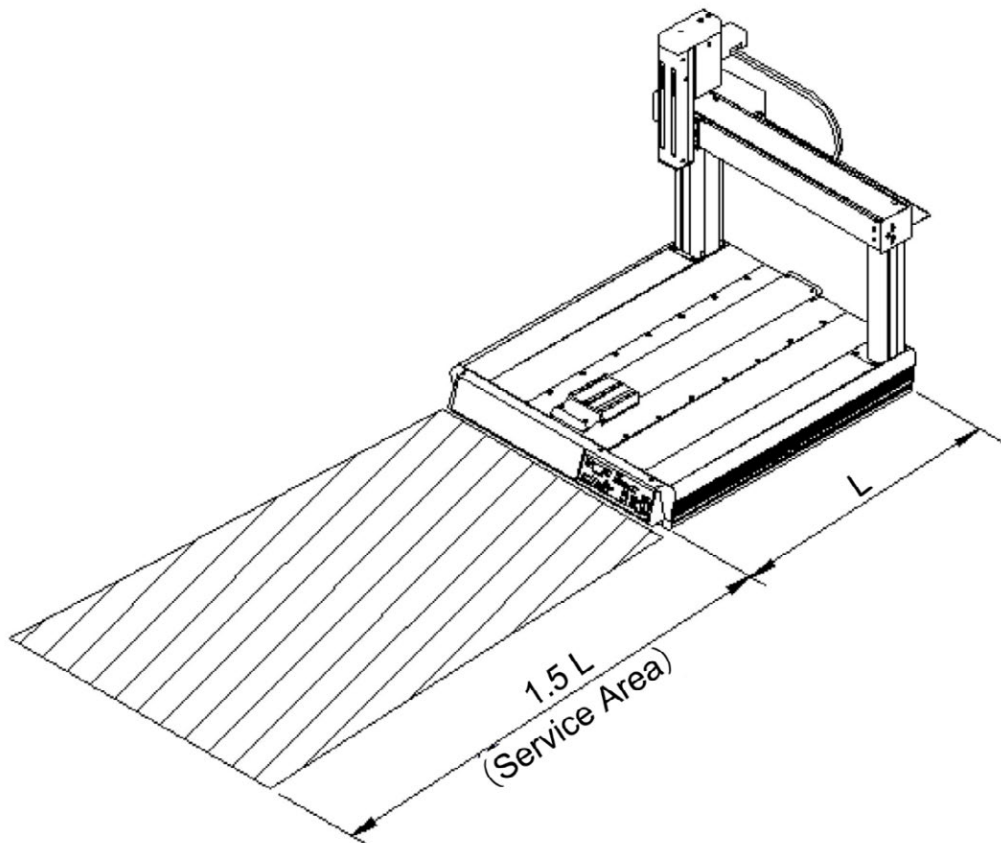

s) EC Series

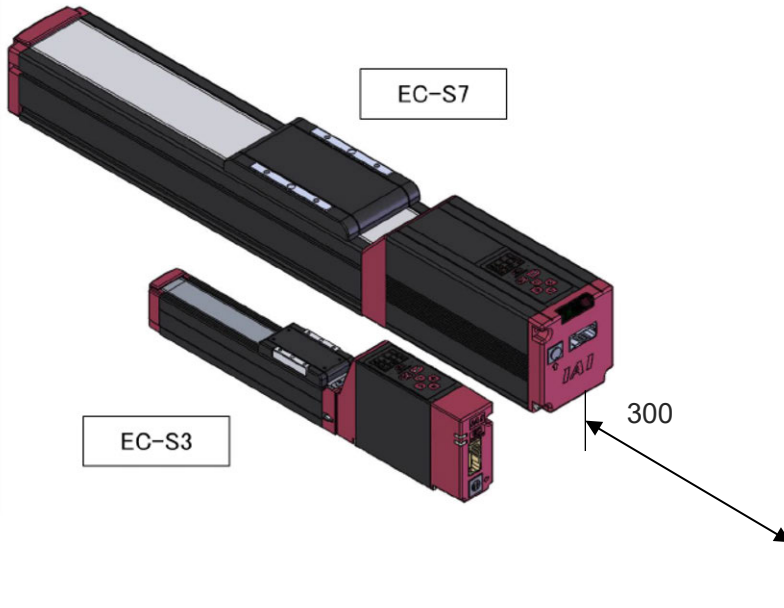

## 2.6 Power Supply

Use (both controller and actuator) under the environment that meets the overvoltage category II or III specified in IEC 60364-4-44: 2007. (For details, refer to [2.4 Environment])

Make sure to install the circuit breaker and leakage breaker complied with the standard specified by the law to 100V AC and 200V AC controllers.

For 24V controller, 200V external supply brake and I/O power supply, use 24V DC power supply that complies with CE Marking which is safety insulated (SELV <sup>(\*)</sup>).

For the wirings of actuator and controller, refer to [Each instruction manual].

\*1 Safety Extra-Low Voltage : SELV (Safty Extra-Low Voltate)

The circuit should be non-grounded and be separated with the double insulation or more than equivalent insulation which would not generate a voltage exceeding 42.4V at peak or 60V DC in the normal condition or single failure condition. Although, a transient voltage up to 71V at peak or 120V DC is to be accepted at a failure. For the secondary circuit of the Class I equipment, the potential difference of the safety ground of a part that a user may be able to touch has to be protected with a structure to avoid a dangerous voltage and the potential difference from the voltage between lines or grounding should be 42.4V at peak, 60V DC or less. (IEC 60950)

## 2.7 Grounding

To prevent an electric shock, make sure to have the ground terminal of the AC power supply cable of the controller and the protective grounding (grounding plate) of the control panel grounded with a “twisted cable” with the wire diameter  $1.3\text{mm}^2$  (AWG16 or equivalent) or more.

## 2.8 Construction of Peripheral Devices and Applicable Units

For some of IAI products to meet the requirements in each directive, it is necessary to follow this manual and install the protection devices such as a circuit breaker and leakage breaker, and noise filters and clamp filters for EMC counteraction. Instruction for each controller is provided below. Please follow the appropriate ones.

Please conduct wirings between these applications with a twisted cable with the wire diameter  $0.5\text{mm}^2$  (AWG20 or equivalent) or more.

Use in a way other than indicated may cause a dissatisfaction in meeting the directive requirements (which disables CE declaration of Conformity). Please contact us in such a case.

Since IAI products are to be installed to variety of systems, the tests are conducted under a certain condition of the installation distance, wirings, etc. and the units are complied with the standards related to EMC Directive under that condition.

However, regarding the EMC performance, it is not possible for us to confirm or ensure the compliance in the condition of customer's use because the condition will differ due to the construction of devices including the host controller (such as PLC), network (<sup>Note 1</sup>) construction, control panel structure, wiring condition and the positions of the devices. Therefore, we would like you to have a responsibility for preparation for CE compliance of the whole equipment.

Note 1 Each fieldbus such as DeviceNet, CC-Link, PROFIBUS, Ethernet, CompoNet that IAI controllers can be applied

In the manual, there is no instruction given when a single cable is required only to go straight through in the clamp filter (1T = 1 turn). Have the cable go into the filter twice if the indication is (2T).

(Number of Turns) = (Number of single cable to go around the inside face of clamp filter) + 1

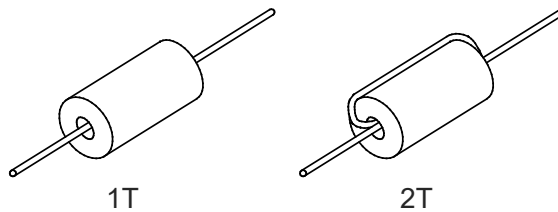

## Actuator Combined with each Controller

Indicated Location (Section No.)	Controller	Combined Actuator
2.8.1	ROBONET-RGW-***	RCA/RCACR/RCAW/RCA2/RCA2CR/RCA2W RCP2/RCP2CR/RCP2W/RCP3
2.8.2	MSEP-C/LC	RCP2/RCP3/RCP4/RCP5/RCA/RCA2 RCP5CR/RCP5W/RCP2CR/RCP2W/RCP4CR/RCP4 W/RCACR/RCAW/RCD
	MCON-C/CG MCON-LC/LCG	RCP2/RCP3/RCP4/RCP5/RCP6/RCA/RCA2 RCP5CR/RCP5W/RCP2CR/RCP2W/RCP4CR/RCP4 W/RCP6W/RCP6CR RCACR/RCAW/RCD
2.8.3	PMEC-C(200V AC type)	RCP2/RCP2CR/RCP2W/RCP3
2.8.4	ACON-C/CG/CY/PL/PO/SE/CA/ CB/CGB/CYB/PLB/POB, ASEP-C/CW	RCA/RCACR/RCAW/RCA2/RCA2CR/RCA2W
	DSEP-C/CW	RCD
	DCON-CA/CB/CGB/CYB/PLB/POB	
2.8.5	PCON-C/CG/CY/PL/PO/SE/CF PSEP-C/CW, RCP2	RCP2/RCP2CR/RCP2W/RCP3
	PCON-CA/CFA	RCP2/RCP3/RCP4/RCP5 RCP2CR/RCP2W/RCP4CR/RCP4W/RCP5CR RCP5W
	PCON-CB/CGB/CFB/CGFB/ CBP/CGBP/CYB/ PLB/POB	RCP2/RCP3/RCP4/RCP5/RCP6 RCP2CR/RCP2W/RCP4CR/RCP4W/RCP5CR RCP5W/RCP6CR/RCP6W
2.8.6	ASEL-C/CS	RCA/RCACR/RCAW/RCA2
	PSEL-C/CS	RCP2/RCP2CR/RCP2W/RCP3
2.8.7	SCON-CB/CGB/LC/LCG CGB-F (for 3000W and 3300W motors) SCON-C/CA (*1) SCON-CAL/CGAL (*2)	ISA/ISDA/ISDACR/ISDCR(ESD)/ISWA ISPA/ISPDA/ISPDACR/ISPWA ISB/ISDB/ISDBCR ISPB/ISPDB/ISPDBCR SSPA/SSPDACR NS/NSA/IF/IFA/FS/RS/DD/DDCR/DDW/DDA/DDACR
	2.8.8	RCS2/RCS2CR/RCS2W
	2.8.9	RCS3/RCS3P/RCS3CR/RCS3PCR
	2.8.10	RCS4/RCS4CR
	2.8.11	
	2.8.12	
	2.8.13	
	2.8.14	IXA (*3)
	2.8.15	IX
	2.8.16	TTA (Integrated actuator and controller)
	2.8.17	ERC/ERC2/ERC3 (Integrated actuator and controller)

Note 1 SCON-C/CA is not applicable for RCS4/RCS4CR.

Note 2 There are some actuators unavailable to connect to SCON-CAL/CGAL.

Check those actuators in the [Instruction manual for SCON-CAL/CGAL].

Note 3 IXA is applicable only for XSEL-RAX/SAX.

Indicated Location (Section No.)	Controller		Combined Actuator
2.8.18	MSEL-PC/PG/PCF/PGF		RCP2/RCP3/RCP4/RCP5/RCP6 RCP2CR/RCP2W/RCP4CR/RCP4W/RCP5CR RCP5W/RCP6CR/RCP6W
2.8.29	MSEL-PGX		IXP
2.8.20 2.8.21 2.8.22	RCON RSEL	RCON-PC/PCF	RCP2/RCP3/RCP4/RCP5/RCP6 RCP2CR/RCP4CR/RCP5CR/RCP6CR RCP2W/RCP4W/RCP5W/RCP6W
		RCON-AC	RCA/RCA2/RCACR/RCAW/RCL
		RCON-DC	RCD
		RCON-SC	RCS2/RCS3/RCS3P/RCS4 RCS2CR/RCS3CR/RCS3PCR/RCS4CR RCS2W ISA/ISPA/ISB/ISPB/ISDA/ISDA/ISDB/ISPDB ISDACR/ISPDACR/ISDBCR/ISPDBCR SSPA/SSPDACR/IF/IFA/FS/RS/NS/NSA DD/DDA/DDCR/DDACR/DDW LSA/LSAS ISWA/ISPWA
2.8.23	REC	RCON-EC	EC
2.8.24	EC		EC (Integrated actuator and controller)
2.8.25	EC200V		EC200V (Integrated actuator and controller)



### Caution

- Do not have the motor/encoder cable and I/O cable connected to the controller with their lengths exceeding the following values.
  - Controllers with power voltage 100/200V : 30m
  - Controllers with power voltage 24V except for ERC2/ERC3 and RCD: 20m
  - ERC2/ERC3 and RCD: 10m
- For those controllers getting the brake power supplied from an external device, use a shielded 2-core (1-paired) twisted cable with AWG16 to 20 (1.25 to 0.5mm<sup>2</sup>), and ground the shield on the 24V DC power supply side.
- For the cable to connect the safety relay unit and the system I/O used in XSEL-Q/QX/SA/SAX type controller, use a shielded 9-paired (or more) twisted cable with AWG16 to 20 (1.25 to 0.5mm<sup>2</sup>), and ground the shield on the safety relay unit side. However, there is no specific restriction if it is XSEL-P/PX/RA/RAX type and connected directly to the emergency stop switch (with 2 cable cores).
- Ensure that the cable connected to the WLAN/Bluetooth converter does not exceed the length specified below.
  - Power supply cable : 3m
  - Ethernet Cable : 10m

2.8.1 ROBONET-RGW

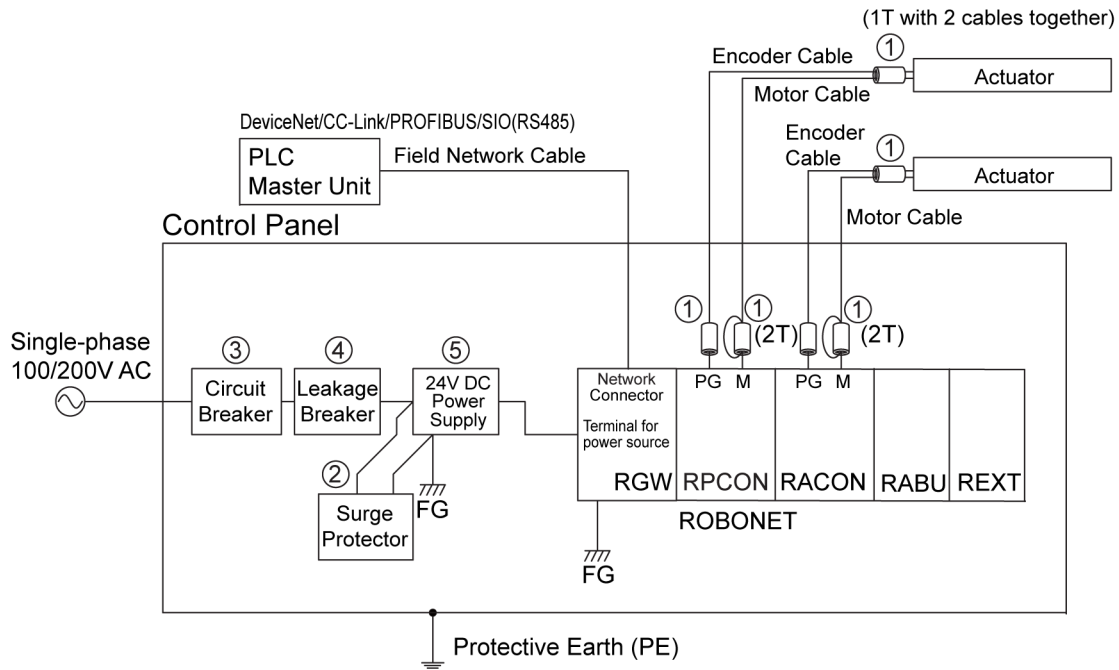

[Examples of components for EMC counteraction and protection devices and power source to ensure safety]

No.	Name	Model	Supplier	Quantity	Remarks
①	Clamp Filter (1)	ZCAT3035-1330	TDK Corporation	3×Number of Axes	
②	Surge Protector (1)	R•A•V-781BWZ-2A	OKAYA Electric Industries Co., Ltd.	1	
③	Circuit Breaker (1)	NF32-SVF-3P-15A	Mitsubishi Electric Corporation	1	100V/200V AC Input in common
④	Leakage Breaker (1)	NV32-SVF-2P-15A-AC100-240V-30mA-CE•CCC	Mitsubishi Electric Corporation	1	100V/200V AC Input in common
⑤	24V DC Power Supply (1)	ZWS150BAF-24	TDK-Lambda Corporation	1	100V/200V AC Input in common

\* The number in the brackets shows the part number described below.

Even though the diagram shown above is that for 2-axis actuator, the same treatment is required also for other cases no matter how many axes.

Mount the clamp filter as close to the cable terminal as possible, and affix with a zip ties so it would not move.

Also, put the motor cable and encoder cable together into one clamp filter on the actuator side.

Have 2 turns on the controller side for the motor cable.

The circuit breaker, leakage breaker and 24V DC power supply are the delegated samples. When choosing a circuit breaker, choose one that the cutoff current would not trip with the in-rush current.

Choose a harmonic and surge-applicable type for the leakage breaker.

Choose a CE complied type that is safety-insulated one for the 24V DC power supply.

In the actual use, the setting will vary depending on the capacity of the combined actuator. Choose the appropriate equipment following [ROBONET Instruction Manual].

2.8.2 MSEP-C/LC, MCON-C/CG, MCON-LC/LCG

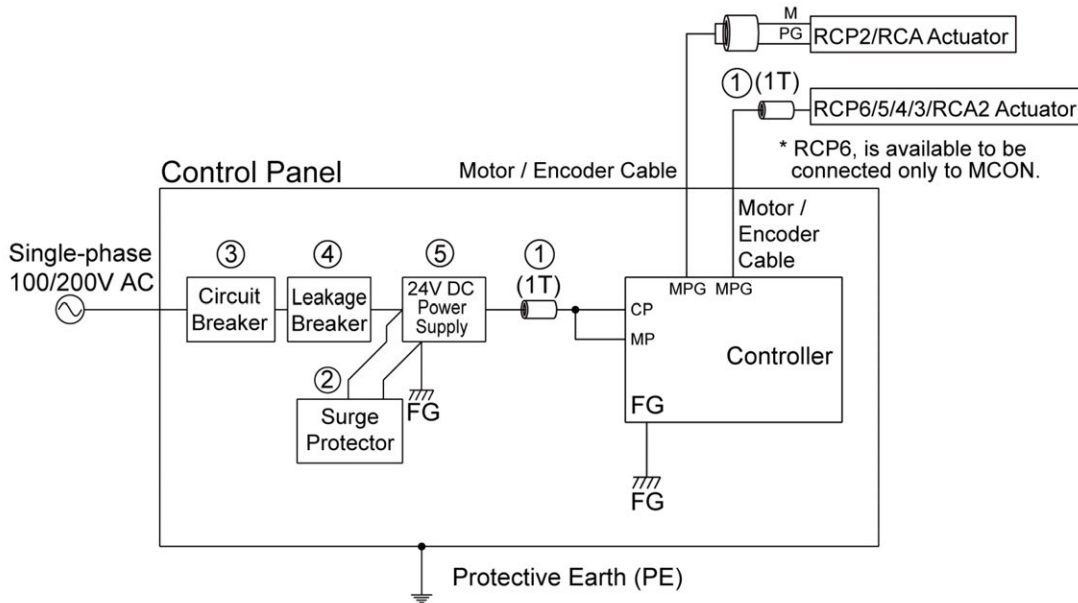

[Examples of components for EMC counteraction and protection devices and power source to ensure safety]

No.	Name	Model	Supplier	Quantity	Remarks
①	Clamp Filter (1)	ZCAT3035-1330	TDK Corporation	1+Number of Axes	
②	Surge Protector (1)	R•A•V-781BWZ-2A	OKAYA Electric Industries Co., Ltd.	1	
③	Circuit Breaker (1)	NF32-SVF-3P-15A	Mitsubishi Electric Corporation	1	100V/200V AC Input in common
④	Leakage Breaker (1)	NV32-SVF-2P-15A-AC100-240V-30mA-CE•CCC	Mitsubishi Electric Corporation	1	100V/200V AC Input in common
⑤	24V DC Power Supply (3)	ADA600F-24	COSEL	1	100V/200V AC Input in common

\* The number in the brackets shows the part number described below.

Mount the clamp filter as close to the cable terminal as possible, and affix with a zip ties so it would not move.

If the actuator is RCA2/RCP6/RCP5/RCP4 or RCP3, the wires for motor and encoder are integrated in one cable, thus put that cable into the clamp filter in this case.

If the actuator is RCP2, RCA it has separate motor cable and encoder cable. In this case, put two cables together into one clamp filter.

The circuit breaker, leakage breaker and 24V DC power supply are the delegated samples. When choosing a circuit breaker, choose one that the cutoff current would not trip with the in-rush current.

Choose a harmonic and surge-applicable type for the leakage breaker.

Choose a CE complied type that is safety-insulated one for the 24V DC power supply.

In the actual use, the setting will vary depending on the capacity of the combined actuator. Choose the appropriate equipment following the instruction manual of each model.

2.8.3 P MEC-C (200V AC Power Supply Type)

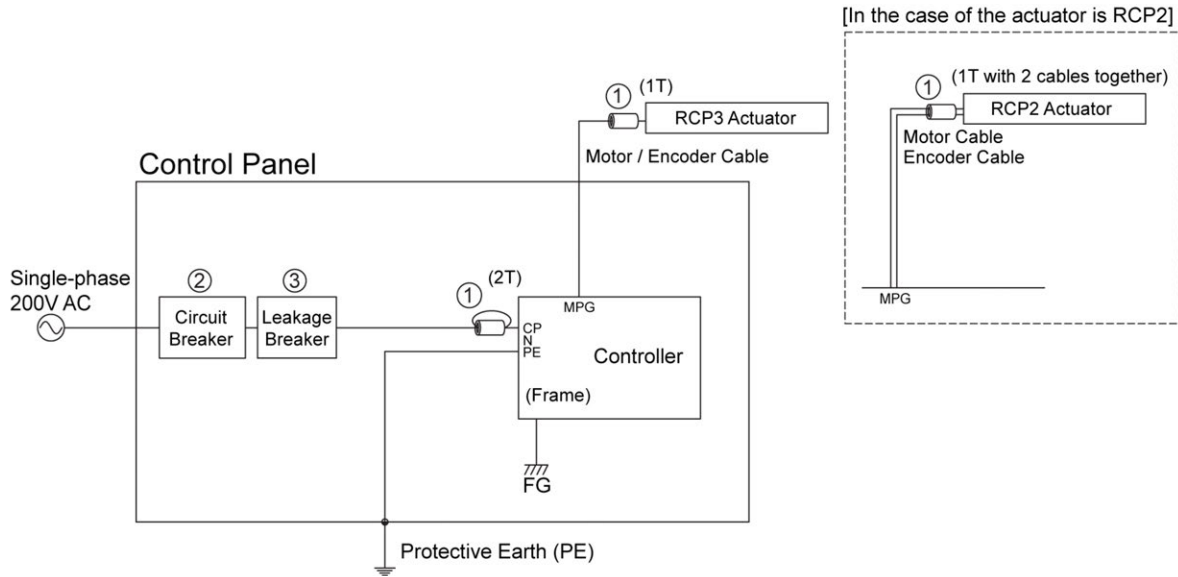

2: CE Marking

[Examples of components for EMC counteraction and protection devices to ensure safety]

No.	Name	Model	Supplier	Quantity	Remarks
①	Clamp Filter (2)	E04SR401938	SEIWA Electronics Co., Ltd	2	
②	Circuit Breaker (1)	NF32-SVF-3P-15A	Mitsubishi Electric Corporation	1	
③	Leakage Breaker (1)	NV32-SVF-2P-15A-AC100-240V-30mA-CE•CCC	Mitsubishi Electric Corporation	1	

\* The number in the brackets shows the part number described below.

Mount the clamp filter as close to the cable terminal as possible, and affix with a zip ties so it would not move.

If the actuator is RCP3, the wires for motor and encoder are integrated in one cable, thus put that cable into the clamp filter in this case.

If the actuator is RCP2, it has separate motor cable and encoder cable. In this case, put two cables together into one clamp filter.

For the 200V AC power cable, have 2 turns on the P MEC end at the point closer than or equal to 120mm.

The circuit breaker and the leakage breaker are the delegated samples.

When choosing a circuit breaker, choose one that the cutoff current would not trip with the in-rush current.

Choose a harmonic and surge-applicable type for the leakage breaker.

In the actual use, the setting will vary depending on the capacity of the combined actuator. Choose the appropriate equipment following [PMEC/AMEC MEC Controller Instruction Manual].



### Caution

- 100V AC power supply type PMEC does not comply with the CE mark.
-

**2.8.4 ACON-C/CG/CY/PL/PO/SE/CA/CB/CGB/CYB/PLB/POB,  
DCON-CA/CB/CGB/CYB/PLB/POB, ASEP-C/CW, DSEP-C/CW**

Controller : ACON-C/CG/CY/PL/PO/SE

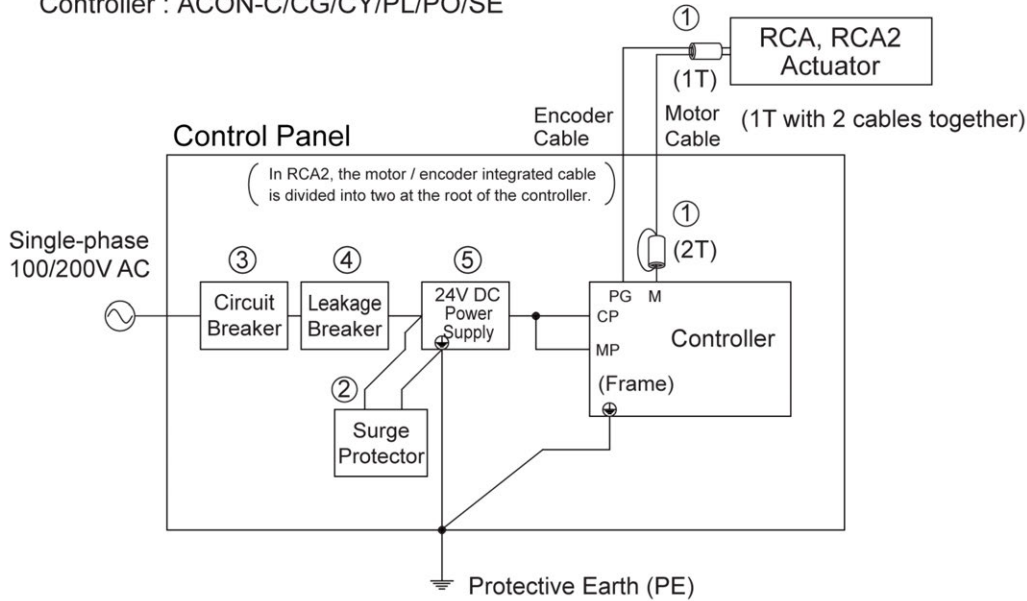

Controller : DCON-CA/CB/CGB/  
CYB/PLB/POB  
DSEP-C/CW

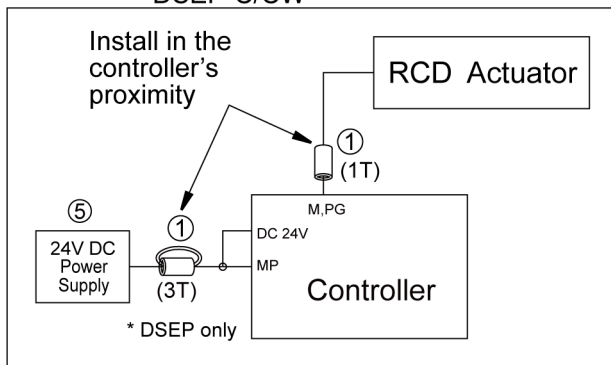

Controller : ACON-CA/CB/CGB/  
CYB/PLB/POB  
ASEP-C/CW

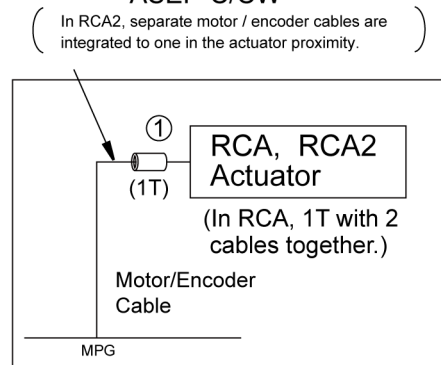

\* It is not necessary to attach a clamp filter on the power supply cable.

[Examples of components for EMC counteraction and protection devices and power source to ensure safety]

No.	Name	Model	Supplier	Quantity	Remarks
①	Clamp Filter (1)	ZCAT3035-1330	TDK Corporation	1 or 2	
②	Surge Protector (1)	R•A•V-781BWZ-2A	OKAYA Electric Industries Co., Ltd.	1	
③	Circuit Breaker (1)	NF32-SVF-3P-15A	Mitsubishi Electric Corporation	1	100V/200V AC Input in common
④	Leakage Breaker (1)	NV32-SVF-2P-15A-AC100-240V-30mA-CE•CCC	Mitsubishi Electric Corporation	1	100V/200V AC Input in common
⑤	24V DC Power Supply (1)	ZWS150BAF-24	TDK-Lambda Corporation	1	100V/200V AC Input in common

\* The number in the brackets shows the part number described below.

Mount the clamp filter as close to the cable terminal as possible, and affix with a zip ties so it would not move.

If the actuator is RCA2, the wires for motor and encoder are integrated in one cable, thus put that cable into the clamp filter in this case.

If the actuator is RCA it has separate motor cable and encoder cable. In this case, put two cables together into one clamp filter.

If the controller is of ACON-C/CG/CY/PL/PO/SE, have two turns on the controller side. The clamp filter on the controller side is not necessary when the controller is ACON-CA/CB/CGB/CYB/PLB/POB or ASEP-C/CW.

When the controller is DSEP-C/CW or DCON-CA-CB/CGB/CYB/PLB/POB, have one clamp filter mounted on the controller side with one turn and another one clamp filter on the power supply cable with three turns (only for DSEP) near the controller.

The circuit breaker, leakage breaker and 24V DC power supply are the delegated samples.

When choosing a circuit breaker, choose one that the cutoff current would not trip with the in-rush current.

Choose a harmonic and surge-applicable type for the leakage breaker.

Choose a CE complied type that is safety-insulated one for the 24V DC power supply.

In the actual use, the setting will vary depending on the capacity of the combined actuator. Choose the appropriate equipment following the instruction manual of each model.

**2.8.5 PCON-C/CG/CY/PL/PO/SE/CA/CB/CGB/CBP/CGBP/CYB/PLB/POB, RCP2-C/CF, PSEP-C/CW**

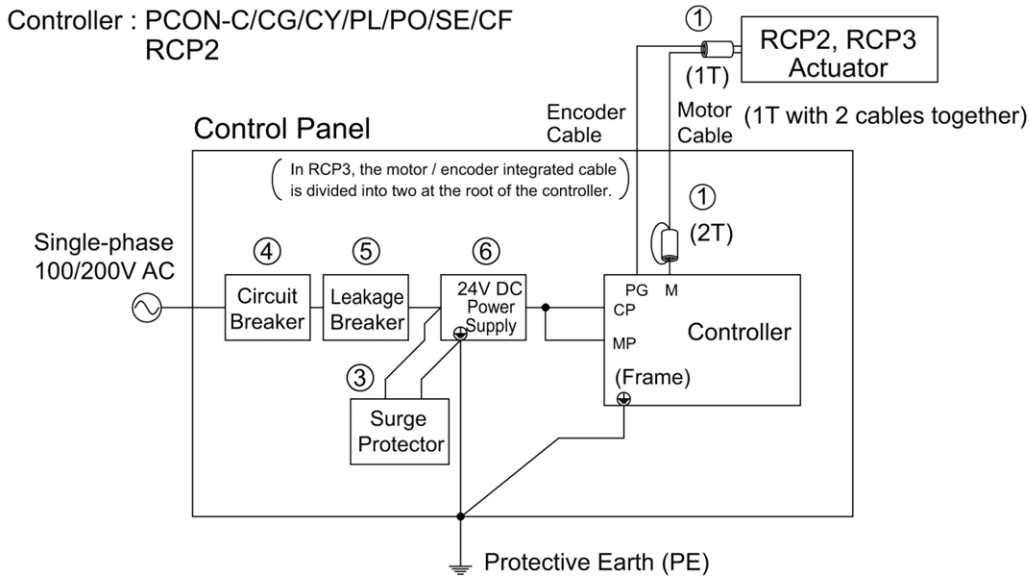

Controller : PCON-CA/CB/CGBCFA/CFB/  
CGFB/CYB/PLB/POB  
PSEP-C/CW

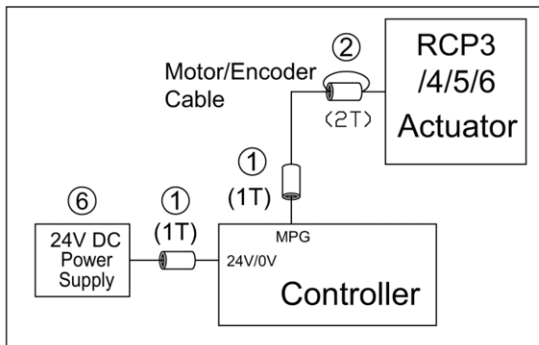

Controller : PCON-CA/CB/CGBCFA/CFB/  
CGFB/CBP/CGBP/CYB/  
PLB/POB/PSEP-C/CW

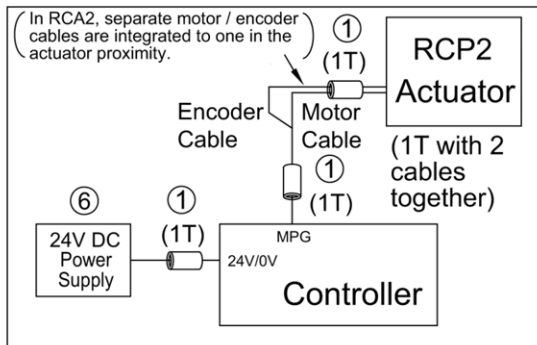

Note PSEP is not applicable for RCP4/5/6. PCON-CA/CFA are not applicable for RCP6.

[Examples of components for EMC counteraction and protection devices and power source to ensure safety]

No.	Name	Model	Supplier	Quantity	Remarks
①	Clamp Filter (1)	ZCAT3035-1330	TDK Corporation	2 or 3	Quantity differs depending on the actuator. Refer to the [above figure]
②	Clamp Filter (2)	E04SR401938	SEIWA Electronics Co., Ltd	1 or 0	
③	Surge Protector (1)	R•A•V-781BWZ-2A	OKAYA Electric Industries Co., Ltd.	1	
④	Circuit Breaker (1)	NF32-SVF-3P-15A	Mitsubishi Electric Corporation	1	100V/200V AC Input in common
⑤	Leakage Breaker (1)	NV32-SVF-2P-15A-AC100-240V-30mA-CE•CCC	Mitsubishi Electric Corporation	1	100V/200V AC Input in common
⑥	24V DC Power Supply (3)	ADA600F-24	COSEL	1	100V/200V AC Input in common

\* The number in the brackets shows the part number described below.

Mount the clamp filter as close to the cable terminal as possible, and affix with a zip ties so it would not move.

If the actuator is RCP6/RCP5/RCP4 or RCP3, the wires for motor and encoder are integrated in one cable, thus put that cable into the clamp filter as shown in diagram on the previous page. If the actuator is RCP2, it has separate motor cable and encoder cable. In this case, put two cables together into one clamp filter.

When the controller is PCON-C/CG/CY/PL/PE/SE/CF or RCP2 (controller dedicated for RCP2/RCP3), have two turns on the controller side.

Also, when the controller is PCON-CA/CB/CGB/CFA/CFB/CGFB/CBP/CGBP/CYB/PLB/POB and the actuator is RCP6/RCP5/RCP4/RCP3, have two turns on the actuator side and one turn on the controller side. When the controller is the same and the actuator is RCP2, have one turn each on the actuator side and controller side. In both cases, have one clamp filter mounted on the power supply cable with one turn.

The circuit breaker, leakage breaker and 24V DC power supply are the delegated samples. When choosing a circuit breaker, choose one that the cutoff current would not trip with the in-rush current.

Choose a harmonic and surge-applicable type for the leakage breaker.

Choose a CE complied type that is safety-insulated one for the 24V DC power supply.

In the actual use, the setting will vary depending on the capacity of the combined actuator. Choose the appropriate equipment following the [instruction manual of each model].

2.8.6 ASEL-C/CS, PSEL-C/CS

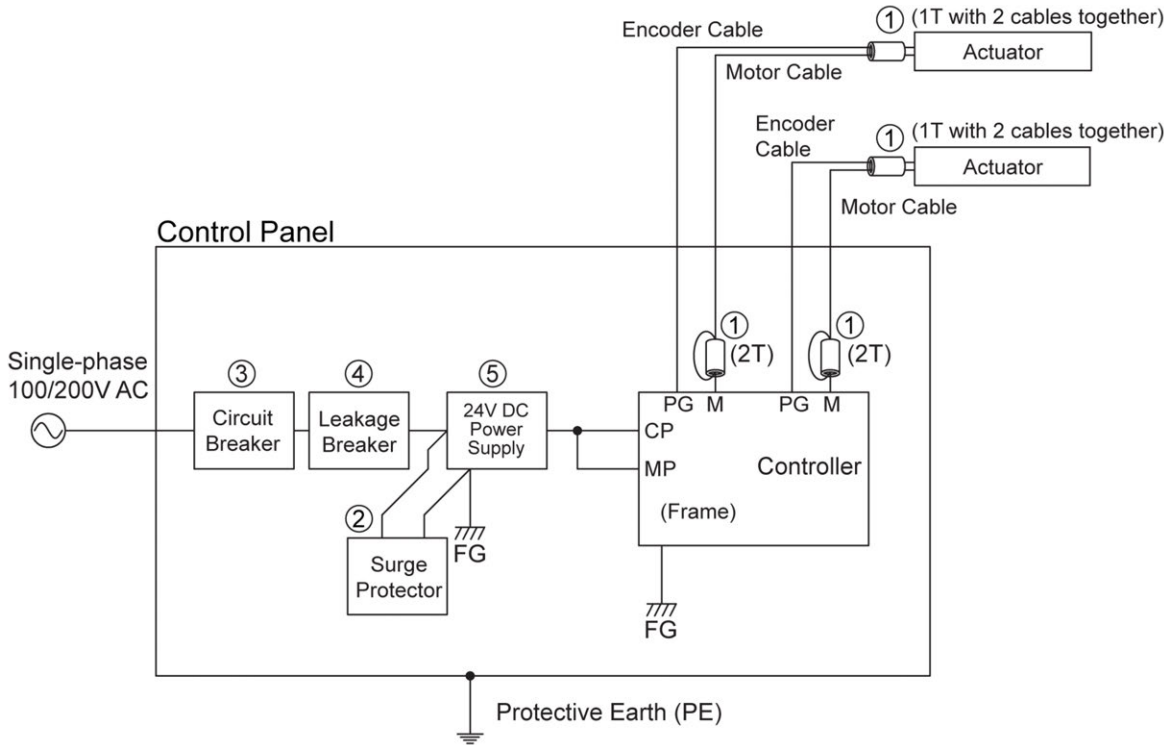

[Examples of components for EMC counteraction and protection devices and power source to ensure safety]

No.	Name	Model	Supplier	Quantity	Remarks
①	Clamp Filter (1)	ZCAT3035-1330	TDK Corporation	2×Number of Axes	
②	Surge Protector (1)	R•A•V-781BWZ-2A	OKAYA Electric Industries Co., Ltd.	1	
③	Circuit Breaker (1)	NF32-SVF-3P-15A	Mitsubishi Electric Corporation	1	100V/200V AC Input in common
④	Leakage Breaker (1)	NV32-SVF-2P-15A-AC100-240V-30mA-CE•CCC	Mitsubishi Electric Corporation	1	100V/200V AC Input in common
⑤	24V DC Power Supply (1)	ZWS150BAF-24	TDK-Lambda Corporation	1	100V/200V AC Input in common

\* The number in the brackets shows the part number described below.

Mount the clamp filter as close to the cable terminal as possible, and affix with a zip ties so it would not move.

Also, put the motor cable and encoder cable together going through (only passing through) in one clamp filter on the actuator end. Have 2 turns on the controller side for the motor cable. It is not necessary to have a clamp filter on the encoder cable.

The circuit breaker, leakage breaker and 24V DC power supply are the delegated samples. When choosing a circuit breaker, choose one that the cutoff current would not trip with the in-rush current.

Choose a harmonic and surge-applicable type for the leakage breaker.

Choose a CE complied type that is safety-insulated one for the 24V DC power supply.

In the actual use, the setting will vary depending on the capacity of the combined actuator. Choose the appropriate equipment following the [instruction manual of each model].

### 2.8.7 SCON-C/CA/CAL/CGAL/CB/CGB/LC/LCGB SCON-CGB-F (for 3000W and 3300W motors)

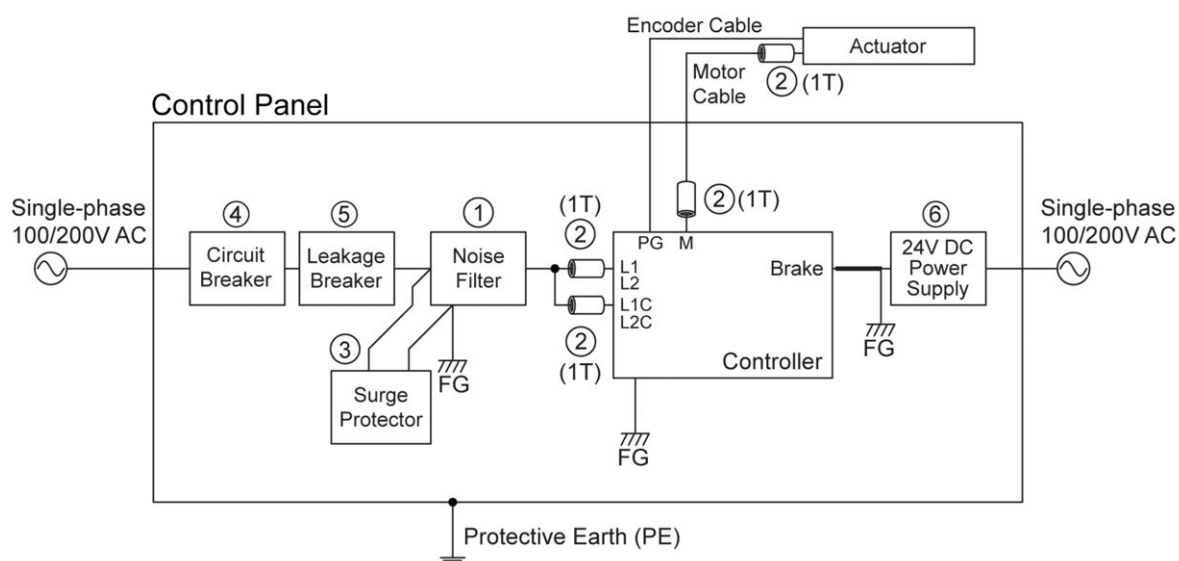

[Examples of components for EMC counteraction and protection devices and power source to ensure safety]

#### SCON-C/CA/CAL/CGAL/CB/CGB/LC/LCG

No.	Name	Model	Supplier	Quantity	Remarks
①	Noise Filter (3)	NAC-10-472	COSEL	1	
		or NF2010A-UP	Soshin Electronics Co., Ltd		
②	Clamp Filter (1)	ZCAT3035-1330	TDK Corporation	4	
③	Surge Protector (1)	R•A•V-781BWZ-2A	OKAYA Electric Industries Co., Ltd.	1	
④	Circuit Breaker (1)	NF32-SVF-3P-15A	Mitsubishi Electric Corporation	1	100V/200V AC Input in common
⑤	Leakage Breaker (1)	NV32-SVF-2P-15A-AC100-240V-30mA-CE•CCC	Mitsubishi Electric Corporation	1	100V/200V AC Input in common
⑥	24V DC Power Supply (2)	ZWS75BAF-24	TDK-Lambda Corporation	1	100V/200V AC Input in common

\* The number in the brackets shows the part number described below.

#### SCON-CGB(For 3000W and 3300W motors)

No.	Name	Model	Supplier	Quantity	Remarks
①	Noise Filter (1)	TAC-20-683	COSEL	1	
②	Clamp Filter (1)	ZCAT3035-1330	TDK Corporation	4	
③	Surge Protector (3)	R•A•V-781BXZ-4	OKAYA Electric Industries Co., Ltd.	1	
④	Circuit Breaker (1)	NF32-SVF-3P-30A	Mitsubishi Electric Corporation	1	
⑤	Leakage Breaker (1)	NV32-SVF-3P-30A-AC100-240V-30mA-CE•CCC	Mitsubishi Electric Corporation	1	
⑥	24V DC Power Supply (2)	ZWS75BAF-24	TDK-Lambda Corporation	1	

\* The number in the brackets shows the part number described below.

Mount the clamp filter as close to the cable terminal as possible, and affix with a zip ties so it would not move.

Have only the motor cable go through in a clamp filter on both the actuator and the controller ends. For the power cable, separate into motor power lines (L1 and L2) and control power lines (L1C and L2C) and put each bundle through the cable clamps.

Attach a noise filter to the point where the cable length is 300mm or less from the controller.

For the brake power supply cable, use a shielded 2-core (1-paired) twisted cable with AWG16 to 20 (1.25 to 0.5mm<sup>2</sup>), and ground the shield on the 24V DC power supply side.

The circuit breaker, leakage breaker and 24V DC power supply are the delegated samples.

When choosing a circuit breaker, choose one that the cutoff current would not trip with the in-rush current.

Choose a harmonic and surge-applicable type for the leakage breaker.

Choose a CE complied type that is safety-insulated one for the 24V DC power supply.

In the actual use, the setting will vary depending on the capacity of the combined actuator. Choose the appropriate equipment following [SCON-C Controller Instruction Manual, SCON-CA Controller Instruction Manual or SCON-CB Controller Instruction Manual].

2.8.8 SCON2-CG

● Block Diagram for Peripheral Devices for SCON2

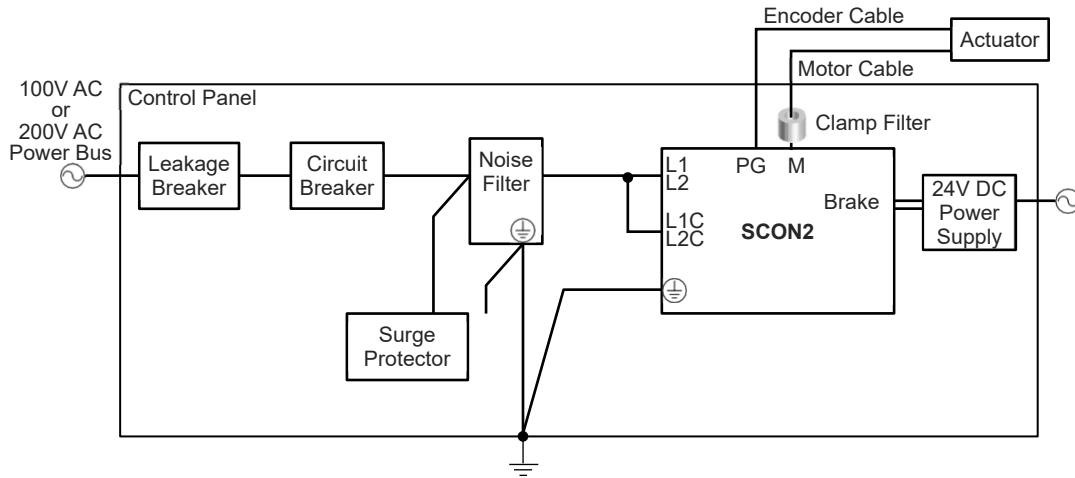

● Block Diagram for Peripheral Devices for SCON2+SU

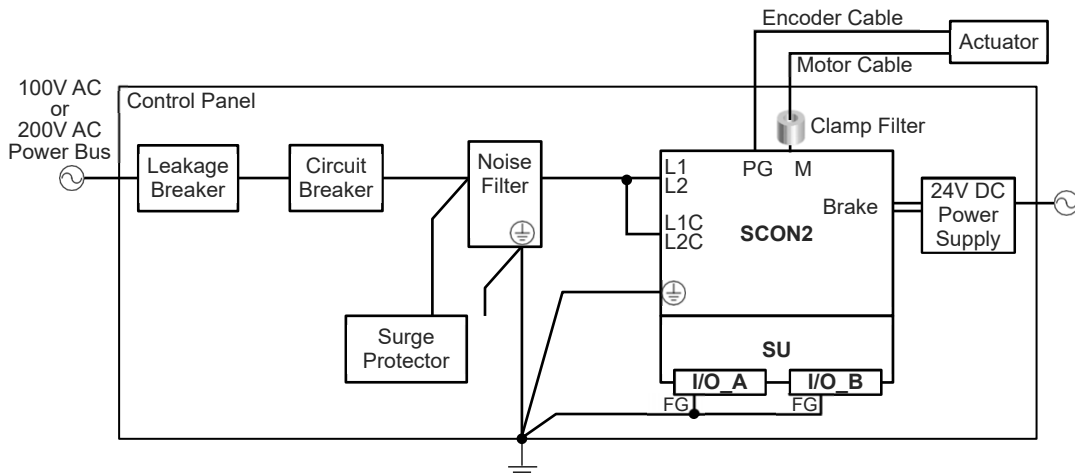

[Examples of components for EMC counteraction and protection devices and power source to ensure safety]

No.	Name	Model	Supplier	Quantity	Remarks
①	Noise Filter (3)	NAC-10-472	COSEL	1	
		or NF2010A-UP	Soshin Electronics Co., Ltd		
②	Clamp Filter (1)	ZCAT3035-1330	TDK Corporation	4	
③	Surge Protector (1)	R•A•V-781BWZ-2A	OKAYA Electric Industries Co., Ltd.	1	
④	Circuit Breaker (1)	NF32-SVF-3P-15A	Mitsubishi Electric Corporation	1	100V/200V AC Input in common
⑤	Leakage Breaker (1)	NV32-SVF-2P-15A-AC100-240V-30mA-CE•CCC	Mitsubishi Electric Corporation	1	100V/200V AC Input in common
⑥	24V DC Power Supply (2)	ZWS75BAF-24	TDK-Lambda Corporation	1	100V/200V AC Input in common

\* The number in the brackets shows the part number described below.

Mount the clamp filter as close to the cable terminal as possible, and affix with a zip ties so it would not move.

Have only the motor cable go through in a clamp filter on both the actuator and the controller ends. For the power cable, separate into motor power lines (L1 and L2) and control power lines (L1C and L2C) and put each bundle through the cable clamps.

Attach a noise filter to the point where the cable length is 300mm or less from the controller.

For the brake power supply cable, use a shielded 2-core (1-paired) twisted cable with AWG16 to 20 (1.25 to 0.5mm<sup>2</sup>), and ground the shield on the 24V DC power supply side.

The circuit breaker, leakage breaker and 24V DC power supply are the delegated samples.

When choosing a circuit breaker, choose one that the cutoff current would not trip with the in-rush current.

Choose a harmonic and surge-applicable type for the leakage breaker.

Choose a CE complied type that is safety-insulated one for the 24V DC power supply.

In the actual use, the setting will vary depending on the capacity of the combined actuator.

Choose the appropriate equipment following [SCON2 Instruction Manual].

2.8.9 MSCON-C

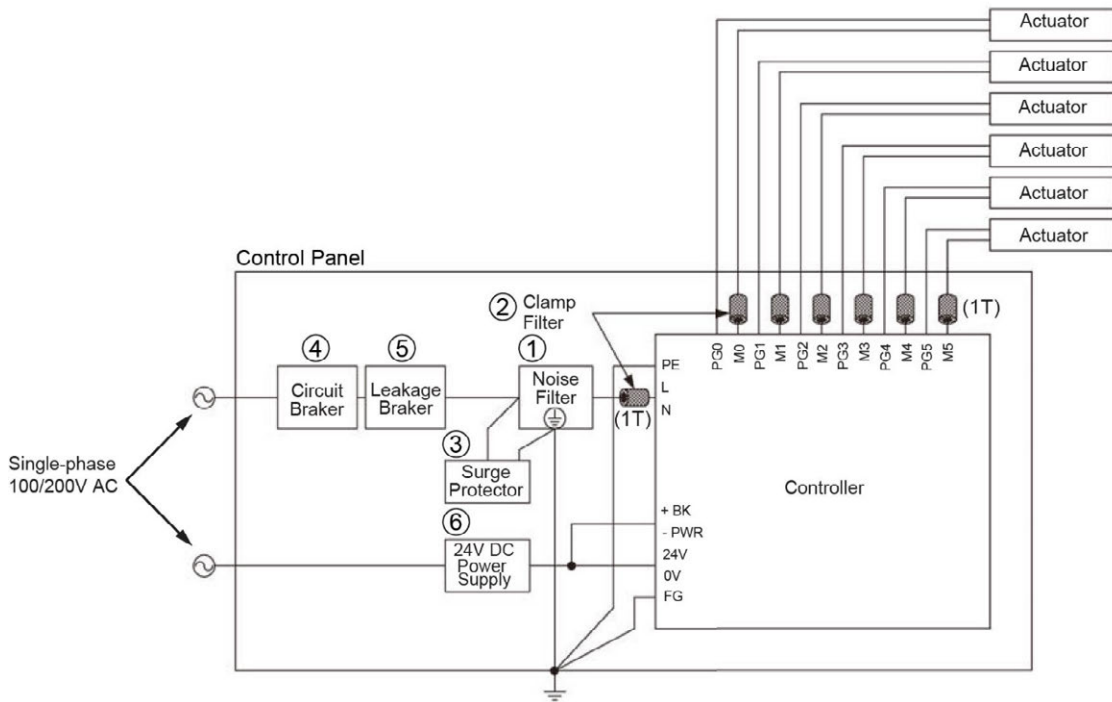

[Examples of components for EMC counteraction and protection devices and power source to ensure safety]

No.	Name	Model	Supplier	Quantity	Remarks
①	Noise Filter (4)	NBC-10-472	COSEL	1	
②	Clamp Filter (1)	ZCAT3035-1330	TDK Corporation	1+Number of Axes	
③	Surge Protector (1)	R•A•V-781BWZ-2A	OKAYA Electric Industries Co., Ltd.	1	
④	Circuit Breaker (1)	NF32-SVF-3P-15A	Mitsubishi Electric Corporation	1	100V/200V AC Input in common
⑤	Leakage Breaker (1)	NV32-SVF-2P-15A-AC100-240V-30mA-CE•CCC	Mitsubishi Electric Corporation	1	100V/200V AC Input in common
⑥	24V DC Power Supply (2)	ZWS75BAF-24	TDK-Lambda Corporation	1	100V/200V AC Input in common

\* The number in the brackets shows the part number described below.

Mount the clamp filter as close to the cable terminal as possible, and affix with a zip ties so it would not move.

Also, put only the motor cable through the clamp filter.

For the power supply cable, pick up only the wires for power supply (L and N) and put together through the cable clamp.

Attach a noise filter to the point where the cable length is 300mm or less from the controller.

For the brake power supply cable, use a shielded 2-core (1-paired) twisted cable with AWG16 to 20 (1.25 to 0.5mm<sup>2</sup>), and ground the shield on the 24V DC power supply side.

The circuit breaker, leakage breaker and 24V DC power supply are the delegated samples. When choosing a circuit breaker, choose one that the cutoff current would not trip with the in-rush current.

Choose a harmonic and surge-applicable type for the leakage breaker.

Choose a CE complied type that is safety-insulated one for the 24V DC power supply.

In the actual use, the setting will vary depending on the capacity of the combined actuator.

Choose the appropriate equipment following [MSCON Controller Instruction Manual].

## 2.8.10 SSEL-C/CS

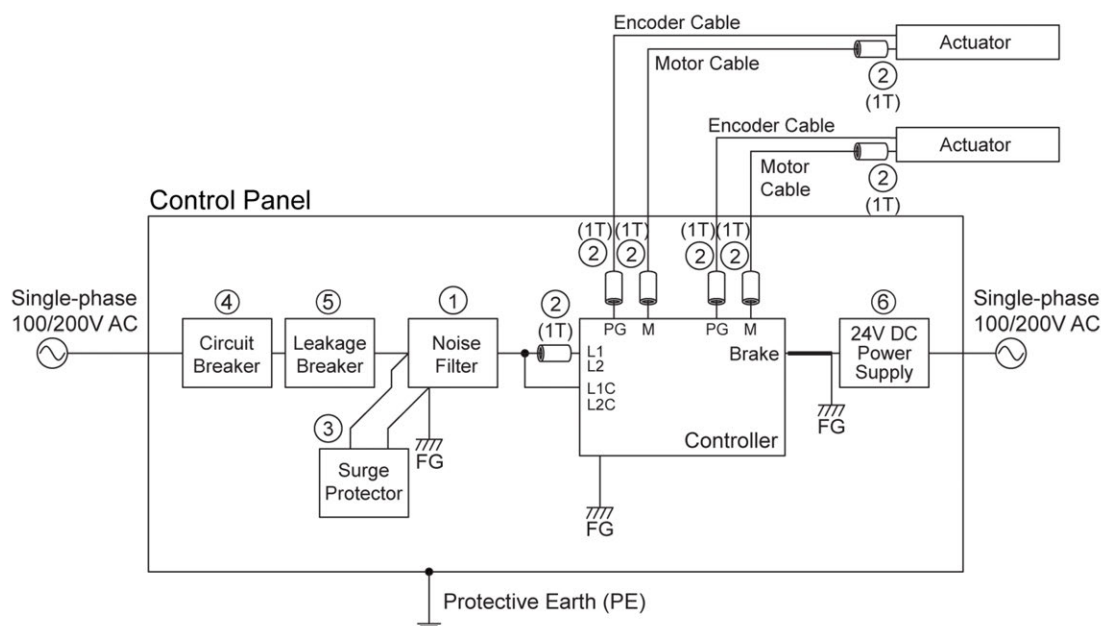

[Examples of components for EMC counteraction and protection devices and power source to ensure safety]

No.	Name	Model	Supplier	Quantity	Remarks
①	Noise Filter (3) *1	NAC-10-472	COSEL	1	
		NF2010A-UP	Soshin Electronics Co., Ltd		
②	Clamp Filter (1)	ZCAT3035-1330	TDK Corporation	3×Number of Axes+1	
③	Surge Protector (1)	R•A•V-781BWZ-2A	OKAYA Electric Industries Co., Ltd.	1	
④	Circuit Breaker (1)	NF32-SVF-3P-15A	Mitsubishi Electric Corporation	1	100V/200V AC Input in common
⑤	Leakage Breaker (1)	NV32-SVF-2P-15A-AC100-240V-30mA-CE•CCC	Mitsubishi Electric Corporation	1	100V/200V AC Input in common
⑥	24V DC Power Supply (2)	ZWS75BAF-24	TDK-Lambda Corporation	1	100V/200V AC Input in common

\* The number in the brackets shows the part number described below.

\*1 Select from either NAC-10-472 (COSEL) or NF2010A-UP (Soshin Electronics Co., Ltd) for Noise Filter (3).

Mount the clamp filter as close to the cable terminal as possible, and affix with a zip ties so it would not move.

Have the motor cable go through in a clamp filter on both the actuator and the controller ends.

Have only the controller end for the encoder cable to go through in a clamp filter.

For the power cable, separate into motor power lines (L1 and L2) and control power lines (L1C and L2C) and put only the bundle of motor power lines through the cable clamps.

A clamp filter is not needed on the control power lines (L1C and L2C).

Attach a noise filter to the point where the cable length is 300mm or less from the controller.

For the brake power supply cable, use a shielded 2-core (1-paired) twisted cable with AWG16 to 20 (1.25 to 0.5mm<sup>2</sup>), and ground the shield on the 24V DC power supply side.

The circuit breaker, leakage breaker and 24V DC power supply are the delegated samples.

When choosing a circuit breaker, choose one that the cutoff current would not trip with the in-rush current.

Choose a harmonic and surge-applicable type for the leakage breaker.

Choose a CE complied type that is safety-insulated one for the 24V DC power supply.

In the actual use, the setting will vary depending on the capacity of the combined actuator. Choose the appropriate equipment following [SSEL Controller Instruction Manual].

2.8.11 XSEL2

[For Single-phase Power Supply]

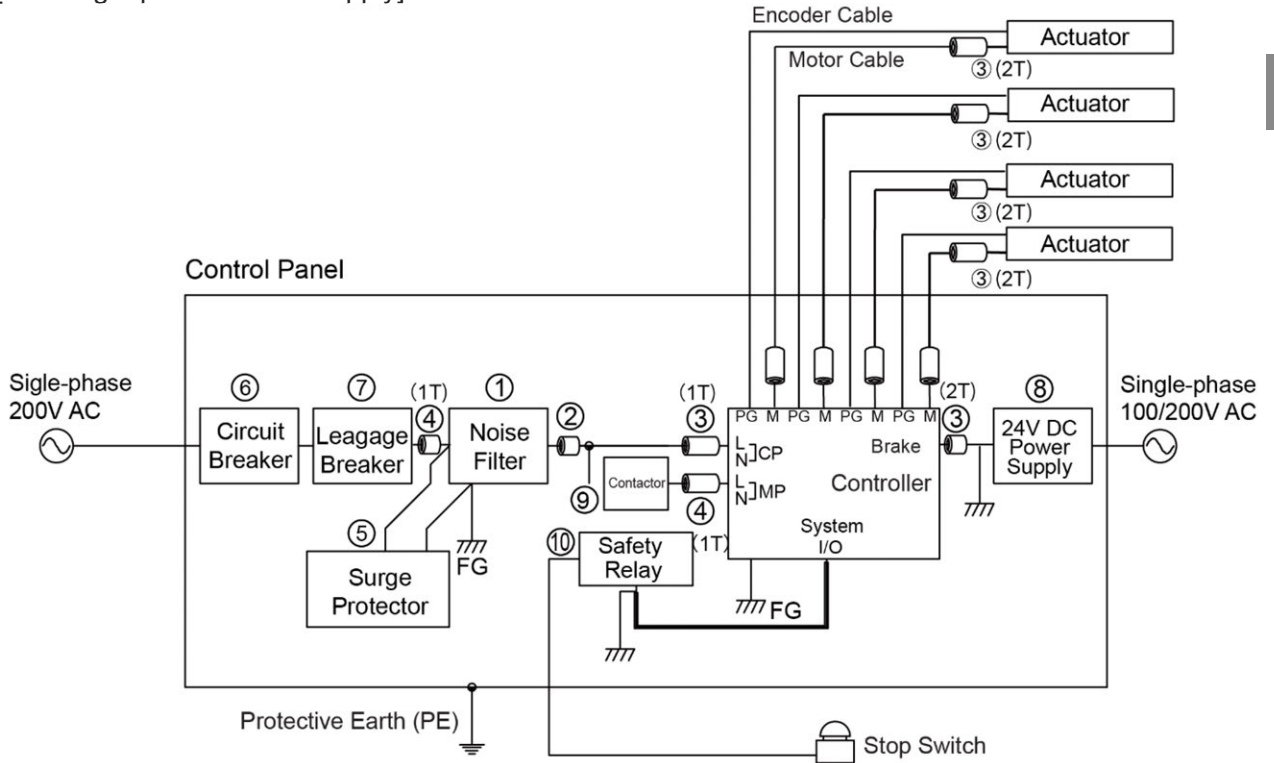

[For 3-phase Power Supply]

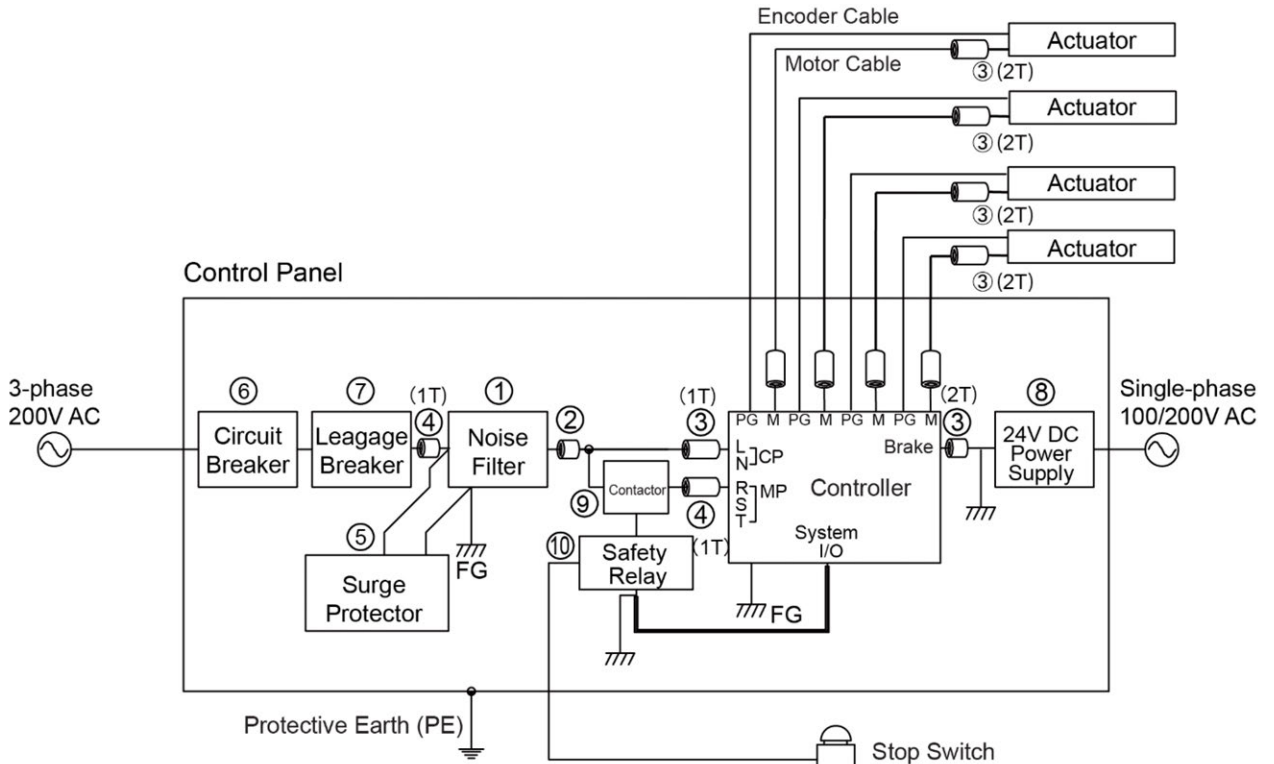

[Examples of components for EMC counteraction and protection devices and power source to ensure safety]

No.	Name	Model	Supplier	Quantity	Remarks
①	Noise Filter (6) *1	FSB-30-324-H	COSEL	1	For 3-phase / Single-phase power supply in common
		HF3030C-SZA	Soshin Electronics Co., Ltd		
②	Ring Core	ESD-R-25	TOKIN Corporation	1	
③	Clamp Filter (1)	ZCAT3035-1330	TDK Corporation	2+2×Number of Axes	
④	Clamp Filter (2)	E04SR401938	SEIWA Electronics Co., Ltd	1	
⑤	Surge Protector (3)	R•A•V-781BXZ-4	OKAYA Electric Industries Co., Ltd.	1	For 3-phase power supply type
	Surge Protector (1)	R•A•V-781BWZ-2A	OKAYA Electric Industries Co., Ltd.	1	For Single-phase power supply type
⑥	Circuit Breaker (1)	NF32-SVF-3P-15A	Mitsubishi Electric Corporation	1	100V/200V AC Input in common
⑦	Leakage Breaker (1)	NV32-SVF-3P-15A-AC100-240V-30mA-CE•CCC	Mitsubishi Electric Corporation	1	100V/200V AC Input in common
⑧	24V DC Power Supply (4)	S8JX-N15024C	OMRON	1	
⑨	Contactator (1)	SC-0/G	Fuji Electric Co., Ltd.	1×Number of Axes	
⑩	Safety Relay (1)	G9SA-301	OMRON	1×Number of Axes	

\* The number in the brackets shows the part number described below.

\*1 Select from either FSB-30-324-H (COSEL) or HF3030C-SZA (Soshin Electronics Co., Ltd) for Noise Filter (6).

Mount the clamp filter as close to the cable terminal as possible, and affix with a zip ties so it would not move.

Have the motor cable go through in a clamp filter on both the actuator and the controller ends. It is not necessary to have a clamp filter on the encoder cable.

For the power cable, separate into motor power lines (1Ph: L and N, 3Ph: R, S and T) and control power lines (1Ph: L and N, 3Ph: L and N) and put each bundle through the cable clamps.

Put the motor and control power lines together and put it through a ring core.

Attach a noise filter to the point where the cable length is 300mm or less from the controller.

For the brake power supply cable, use a shielded 2-core (1-paired) twisted cable with AWG16 to 20 (1.25 to 0.5mm<sup>2</sup>), and ground the shield on the 24V DC power supply side.

For the cable to connect the safety relay unit and the system I/O, use a shielded 9-paired (or more) twisted cable with AWG16 to 24, and ground the shield on the safety relay unit side.

The circuit breaker, leakage breaker and 24V DC power supply are the delegated samples.

When choosing a circuit breaker, choose one that the cutoff current would not trip with the in-rush current. Choose a harmonic and surge-applicable type for the leakage breaker.

Choose a CE complied type that is safety-insulated one for the 24V DC power supply.

XSEL2 type Controller does not possess the drive cutoff circuit inside so a free construction of the safety circuit (⑨ Contactor • ⑩ Safety Relay) suitable for the structure of your equipment can be built outside the controller.

Construct a safety circuit following the instruction manual of the applicable XSEL Controller before start using. Also, as the protection devices listed in the list may not be used, refer to the instruction manual of the applicable XSEL Controller and choose the appropriate protection device.

2.8.12 XSEL-P/RA

[For Single-phase Power Supply]

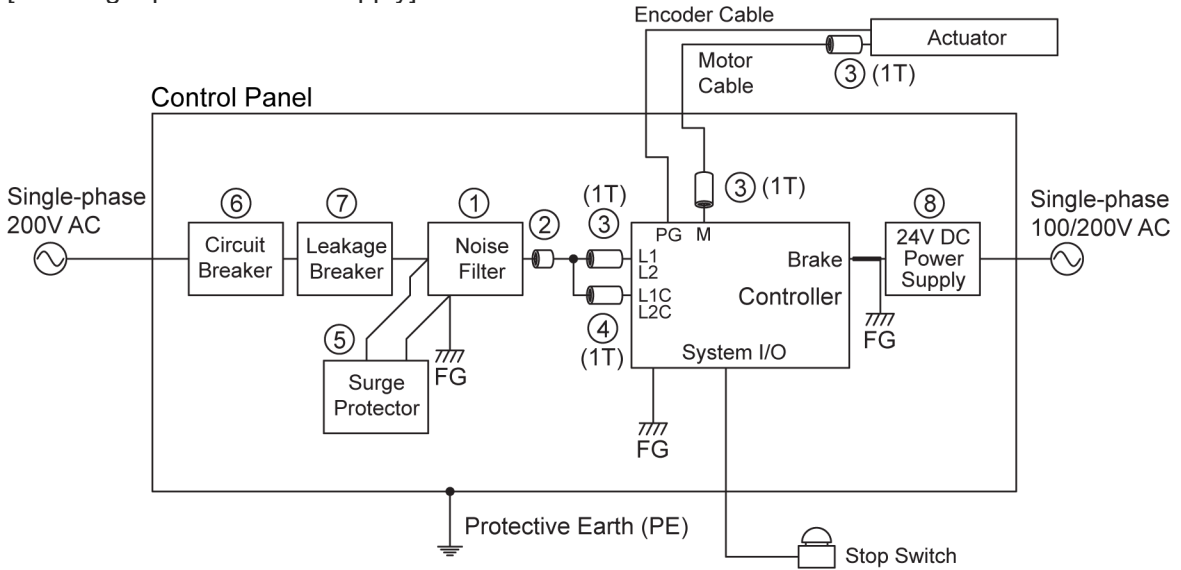

[For 3-phase Power Supply]

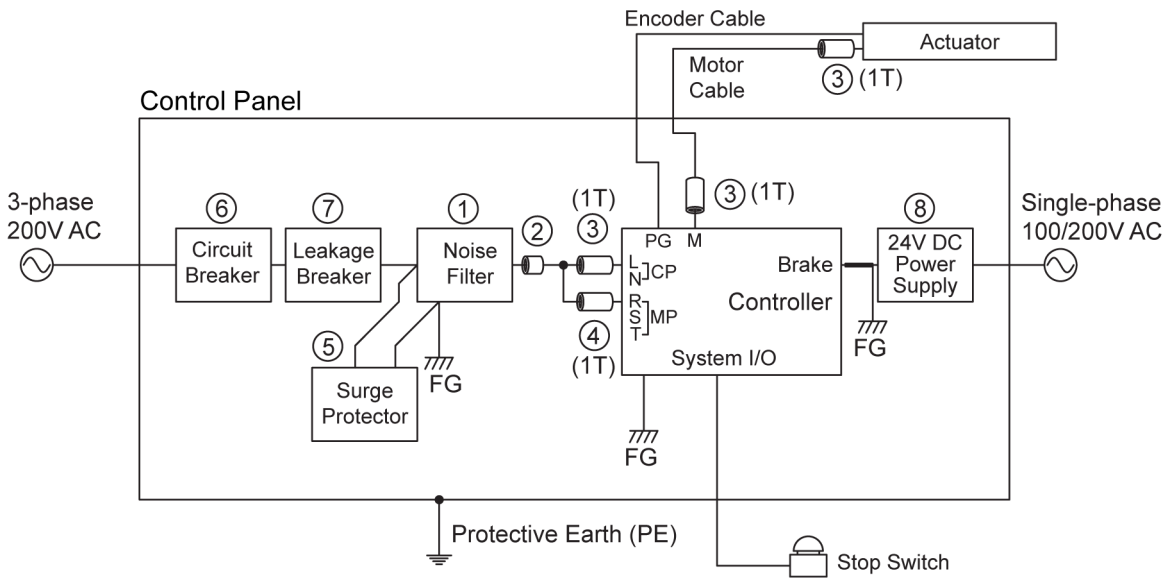

[Examples of components for EMC counteraction and protection devices and power source to ensure safety]

No.	Name	Model	Supplier	Quantity	Remarks
①	Noise Filter (1) *1	TAC-20-683	COSEL	1	For 3-phase power supply type
		NF3020C-SVA	Soshin Electronics Co., Ltd		
	Noise Filter (2) *2	NBH-20-432	COSEL	1	For Single-phase power supply type
		SUP-EL20-ER-6	OKAYA Electric Industries Co., Ltd.		
②	Ring Core	ESD-R-25	TOKIN Corporation	1	
③	Clamp Filter (1)	ZCAT3035-1330	TDK Corporation	1+2×Number of Axes	
④	Clamp Filter (3)	RFC-H13	Kitagawa Industries Co., Ltd	1	
⑤	Surge Protector (3)	R•A•V-781BXZ-4	OKAYA Electric Industries Co., Ltd.	1	For 3-phase power supply type
	Surge Protector (1)	R•A•V-781BWZ-2A	OKAYA Electric Industries Co., Ltd.	1	For Single-phase power supply type
⑥	Circuit Breaker (1)	NF32-SVF-3P-15A	Mitsubishi Electric Corporation	1	100V/200V AC Input in common
⑦	Leakage Breaker (1)	NV32-SVF-3P-15A-AC100-240V-30mA-CE•CCC	Mitsubishi Electric Corporation	1	100V/200V AC Input in common
⑧	24V DC Power Supply (2)	ZWS75BAF-24	TDK-Lambda Corporation	1	100V/200V AC Input in common

\* The number in the brackets shows the part number described below.

\*1 Select from either TAC-20-683 (COSEL) or NF3020C-SVA (Soshin Electronics Co., Ltd) for Noise Filter (1).

\*2 Select from either NBH-20-432 (COSEL) or SUP-EL20-ER-6 (OKAYA Electric Industries Co., Ltd.) for Noise Filter (2).

Mount the clamp filter as close to the cable terminal as possible, and affix with a zip ties so it would not move.

Have the motor cable go through in a clamp filter on both the actuator and the controller ends. It is not necessary to have a clamp filter on the encoder cable.

For the power cable, separate into motor power lines (1Ph: L1 and L2, 3Ph: R, S and T) and control power lines (1Ph: L1C and L2C, 3Ph: L and N) and put each bundle through the cable clamps.

Put the motor and control power lines together and put it through a ring core.

Attach a noise filter to the point where the cable length is 300mm or less from the controller.

For the brake power supply cable, use a shielded 2-core (1-paired) twisted cable with AWG16 to 20 (1.25 to 0.5mm<sup>2</sup>), and ground the shield on the 24V DC power supply side.

The circuit breaker, leakage breaker and 24V DC power supply are the delegated samples. When choosing a circuit breaker, choose one that the cutoff current would not trip with the in-rush current.

Choose a harmonic and surge-applicable type for the leakage breaker.

Choose a CE complied type that is safety-insulated one for the 24V DC power supply.

In the actual use, the protection devices listed in the list may not be used depending on the capacity of the combined actuator. Refer to the [instruction manual of the applicable XSEL Controller] and choose the appropriate protection device.

2.8.13 XSEL-Q/SA

[For Single-phase Power Supply]

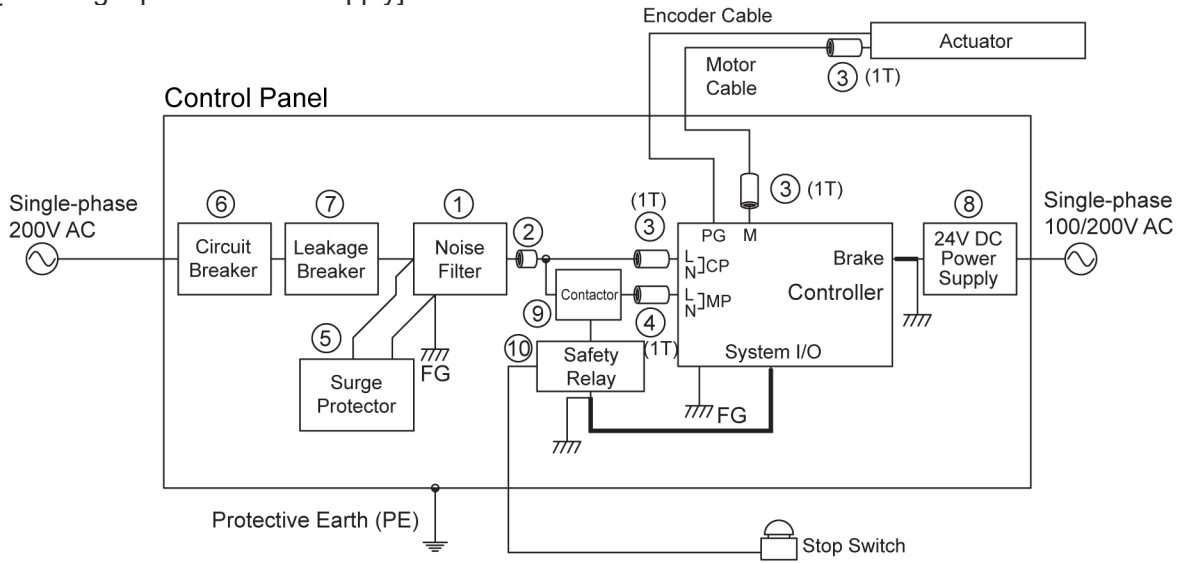

[For 3-phase Power Supply]

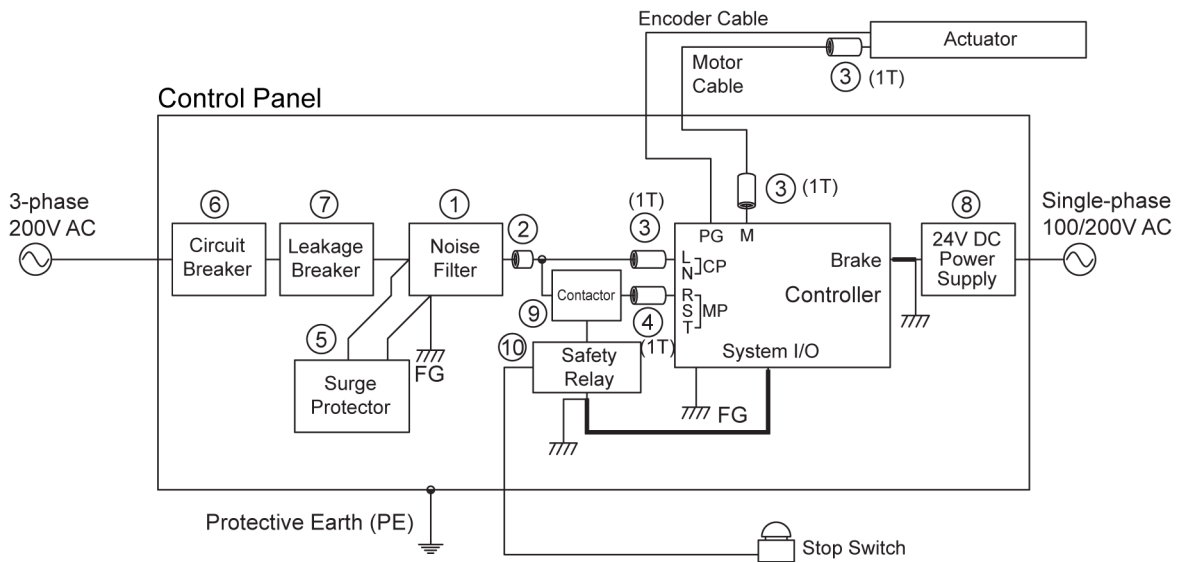

[Examples of components for EMC counteraction and protection devices and power source to ensure safety]

No.	Name	Model	Supplier	Quantity	Remarks
①	Noise Filter (1) *1	TAC-20-683	COSEL	1	For 3-phase power supply type
		NF3020C-SVA	Soshin Electronics Co., Ltd		
	Noise Filter (2) *2	NBH-20-432	COSEL	1	For Single-phase power supply type
		SUP-EL20-ER-6	OKAYA Electric Industries Co., Ltd.		
②	Ring Core	ESD-R-25	TOKIN Corporation	1	
③	Clamp Filter (1)	ZCAT3035-1330	TDK Corporation	1+2×Number of Axes	
④	Clamp Filter (3)	RFC-H13	Kitagawa Industries Co., Ltd	1	
⑤	Surge Protector (3)	R•A•V-781BXZ-4	OKAYA Electric Industries Co., Ltd.	1	For 3-phase power supply type
	Surge Protector (1)	R•A•V-781BWZ-2A	OKAYA Electric Industries Co., Ltd.	1	For Single-phase power supply type
⑥	Circuit Breaker (1)	NF32-SVF-3P-15A	Mitsubishi Electric Corporation	1	100V/200V AC Input in common
⑦	Leakage Breaker (1)	NV32-SVF-3P-15A-AC100-240V-30mA-CE•CCC	Mitsubishi Electric Corporation	1	100V/200V AC Input in common
⑧	24V DC Power Supply (2)	ZWS75BAF-24	TDK-Lambda Corporation	1	100V/200V AC Input in common
⑨	Contactator (1)	SC-0/G	Fuji Electric Co., Ltd.	1×Number of Axes	
⑩	Safety Relay (1)	G9SA-301	OMRON	1×Number of Axes	

\* The number in the brackets shows the part number described below.

\*1 Select from either TAC-20-683 (COSEL) or NF3020C-SVA (Soshin Electronics Co., Ltd) for Noise Filter (1).

\*2 Select from either NBH-20-432 (COSEL) or SUP-EL20-ER-6 (OKAYA Electric Industries Co., Ltd.) for Noise Filter (2).

Mount the clamp filter as close to the cable terminal as possible, and affix with a zip ties so it would not move.

Have the motor cable go through in a clamp filter on both the actuator and the controller ends. It is not necessary to have a clamp filter on the encoder cable.

For the power cable, separate into motor power lines (1Ph: L1 and L2, 3Ph: R, S and T) and control power lines (1Ph: L1C and L2C, 3Ph: L and N) and put each bundle through the cable clamps.

Put the motor and control power lines together and put it through a ring core.

Attach a noise filter to the point where the cable length is 300mm or less from the controller.

For the brake power supply cable, use a shielded 2-core (1-paired) twisted cable with AWG16 to 20 (1.25 to 0.5mm<sup>2</sup>), and ground the shield on the 24V DC power supply side.

For the cable to connect the safety relay unit and the system I/O, use a shielded 9-paired (or more) twisted cable with AWG16 to 24, and ground the shield on the safety relay unit side.

The circuit breaker, leakage breaker and 24V DC power supply are the delegated samples.

When choosing a circuit breaker, choose one that the cutoff current would not trip with the in-rush current. Choose a harmonic and surge-applicable type for the leakage breaker.

Choose a CE complied type that is safety-insulated one for the 24V DC power supply.

XSEL Q/SA type Controller does not possess the drive cutoff circuit inside so a free construction of the safety circuit (⑨ Contactor • ⑩ Safety Relay) suitable for the structure of your equipment can be built outside the controller.

Construct a safety circuit following the instruction manual of the applicable XSEL Controller before start using. Also, as the protection devices listed in the list may not be used, refer to the instruction manual of the applicable XSEL Controller and choose the appropriate protection device.

2.8.14 XSEL-PX/RAX/RAXD

Note: Extra-Small IX (arm length 120/150/180) is excluded

[For Single-phase Power Supply : IX]

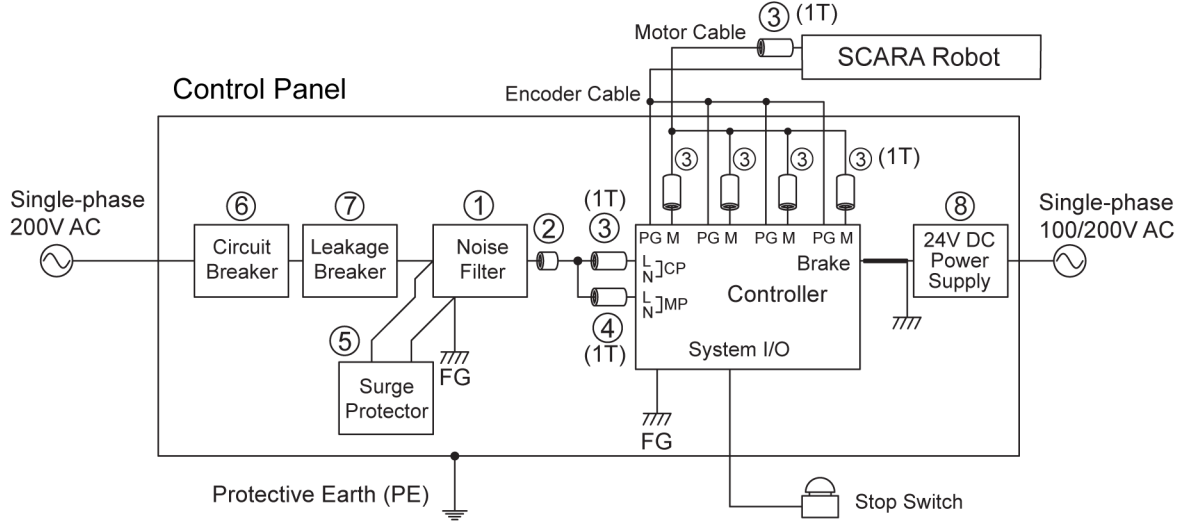

[For 3-phase Power Supply : IX]

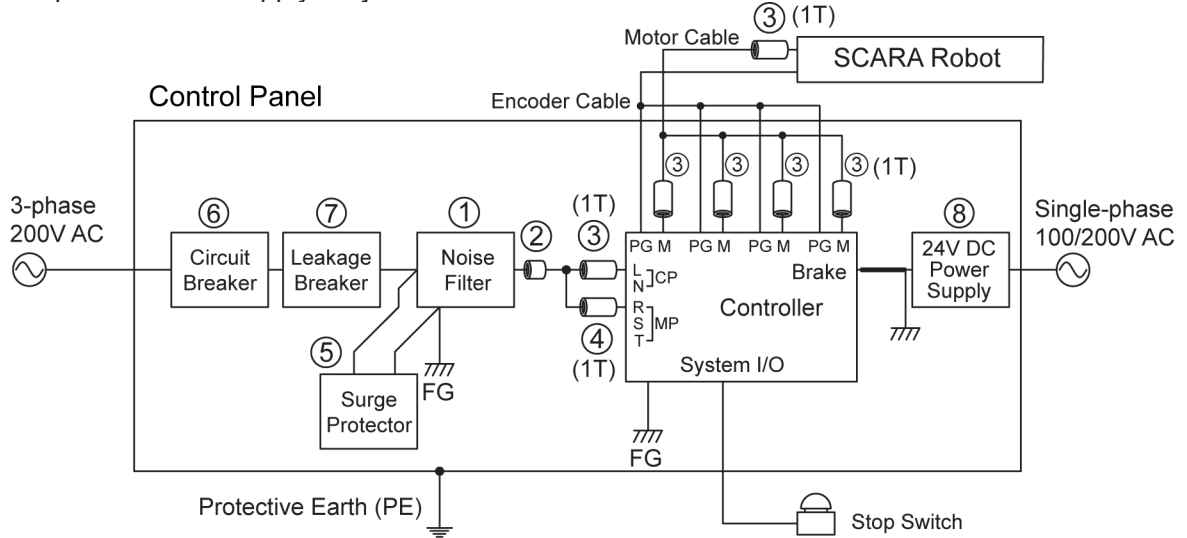

[For 3-phase Power Supply : IXA]

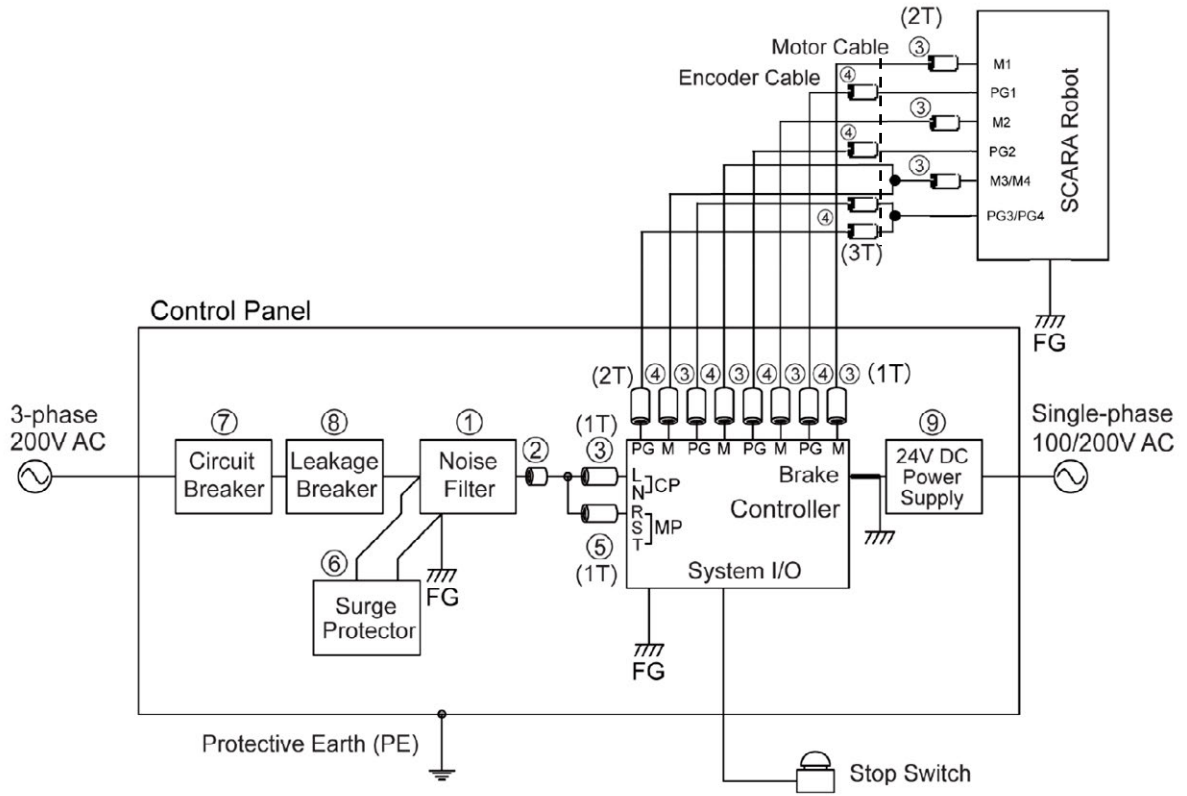

[Examples of components for EMC counteraction and protection devices and power source to ensure safety]

## ● IX

No.	Name	Model	Supplier	Quantity	Remarks
①	Noise Filter (1) *1	TAC-20-683	COSEL	1	For 3-phase power supply type
		NF3020C-SVA	Soshin Electronics Co., Ltd		
	Noise Filter (2) *2	NBH-20-432	COSEL	1	For Single-phase power supply type
		SUP-EL20-ER-6	OKAYA Electric Industries Co., Ltd.		
②	Ring Core	ESD-R-25	TOKIN Corporation	1	
③	Clamp Filter (1)	ZCAT3035-1330	TDK Corporation	6	
④	Clamp Filter (3)	RFC-H13	Kitagawa Industries Co., Ltd	1	
⑤	Surge Protector (3)	R•A•V-781BXZ-4	OKAYA Electric Industries Co., Ltd.	1	For 3-phase power supply type
	Surge Protector (1)	R•A•V-781BWZ-2A	OKAYA Electric Industries Co., Ltd.	1	For Single-phase power supply type
⑥	Circuit Breaker (1)	NF32-SVF-3P-15A	Mitsubishi Electric Corporation	1	100V/200V AC Input in common
⑦	Leakage Breaker (1)	NV32-SVF-3P-15A-AC100-240V-30mA-CE•CCC	Mitsubishi Electric Corporation	1	100V/200V AC Input in common
⑧	24V DC Power Supply (2)	ZWS75BAF-24	TDK-Lambda Corporation	1	100V/200V AC Input in common

\* The number in the brackets shows the part number described below.

\*1 Select from either TAC-20-683 (COSEL) or NF3020C-SVA (Soshin Electronics Co., Ltd) for Noise Filter (1).

\*2 Select from either NBH-20-432 (COSEL) or SUP-EL20-ER-6 (OKAYA Electric Industries Co., Ltd.) for Noise Filter (2).

## ● IXA

No.	Name	Model	Supplier	Quantity	Remarks
①	Noise Filter (1) *1	TAC-20-683	COSEL	1	
		NF3020C-SVA	Soshin Electronics Co., Ltd		
②	Ring Core	ESD-R-25	TOKIN Corporation	1	
③	Clamp Filter (1)	ZCAT3035-1330	TDK Corporation	8	
④	Clamp Filter (2)	E04SR401938	SEIWA Electronics Co., Ltd	7	
⑤	Ring Core (3)	RFC-H13	Kitagawa Industries Co., Ltd	1	
⑥	Surge Protector (3)	R•A•V -781BXZ-4	OKAYA Electric Industries Co., Ltd.	1	
⑦	Circuit Breaker (1)	NF32-SVF-3P-15A	Mitsubishi Electric Corporation	1	
⑧	Leakage Breaker (1)	NV32-SVF-3P-15A-AC100-240V-30mA-CE•CCC	Mitsubishi Electric Corporation	1	
⑨	24V DC Power Supply (4)	S8JX-N15024C	OMRON	1	

\* The number in the brackets shows the part number described below.

\*1 Select from either TAC-20-683 (COSEL) or NF3020C-SVA (Soshin Electronics Co., Ltd) for Noise Filter (1).

Mount the clamp filter as close to the cable terminal as possible, and affix with a zip ties so it would not move.

Have the motor cable go through in a clamp filter on both the actuator and the controller ends. On the actuator side, the motor cable is integrated to one, thus put that cable straight into the clamp filter. It is not necessary to have a clamp filter on the encoder cable.

For the power cable, separate into motor power lines (1Ph: MP-L and N, 3Ph: MP-R, S and T) and control power lines (1Ph / 3Ph: CP-L and N) and put each bundle through the cable clamps.

Put the motor and control power lines together and put it through a ring core.

Attach a noise filter to the point where the cable length is 300mm or less from the controller.

For the brake power supply cable, use a shielded 2-core (1-paired) twisted cable with AWG16 to 20 (1.25 to 0.5mm<sup>2</sup>), and ground the shield on the 24V DC power supply side.

The circuit breaker, leakage breaker and 24V DC power supply are the delegated samples.

When choosing a circuit breaker, choose one that the cutoff current would not trip with the in-rush current.

Choose a harmonic and surge-applicable type for the leakage breaker.

Choose a CE complied type that is safety-insulated one for the 24V DC power supply.

In the actual use, the protection devices listed in the list may not be used depending on the capacity of the combined actuator. Refer to the [instruction manual of the applicable XSEL Controller] and choose the appropriate protection device.

2.8.15 XSEL-QX/SAX/SAXD

Note: Extra-Small IX (arm length 120/150/180) is excluded

[For Single-phase Power Supply : IX]

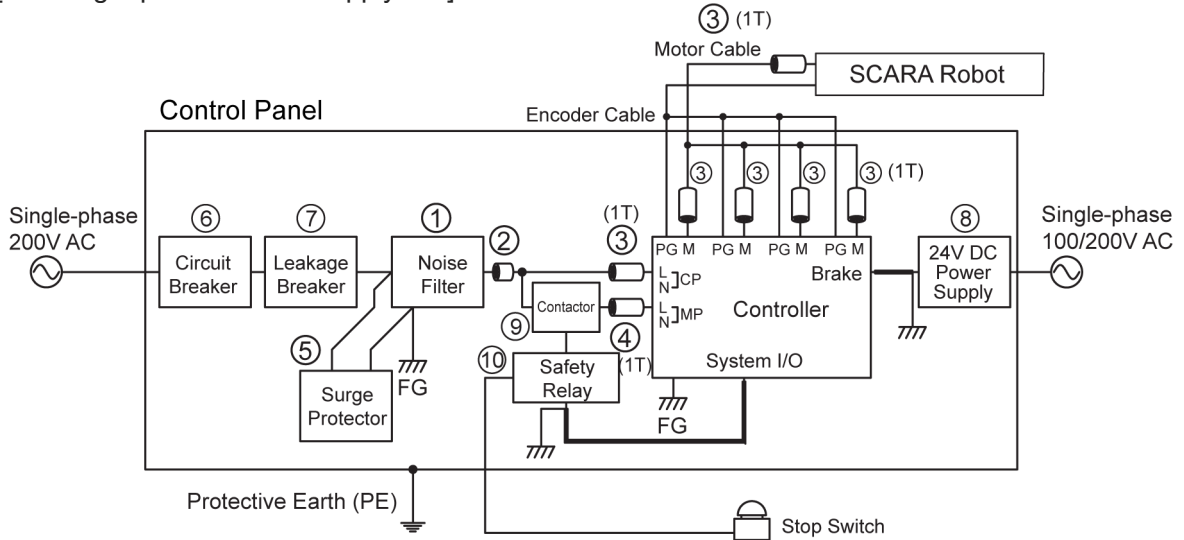

[For 3-phase Power Supply : IX]

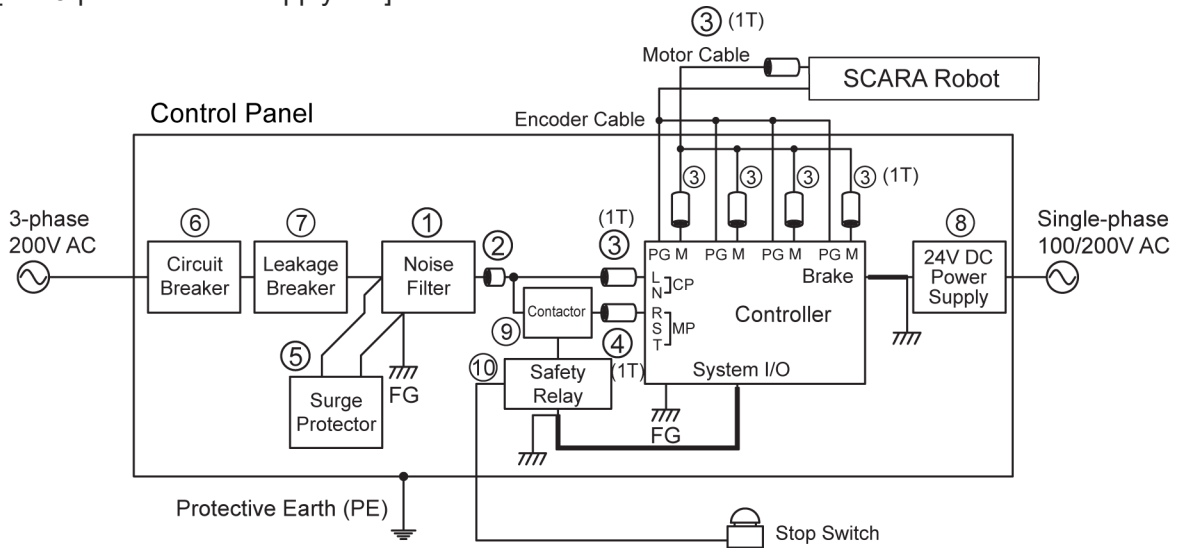

[For 3-phase Power Supply : IXA]

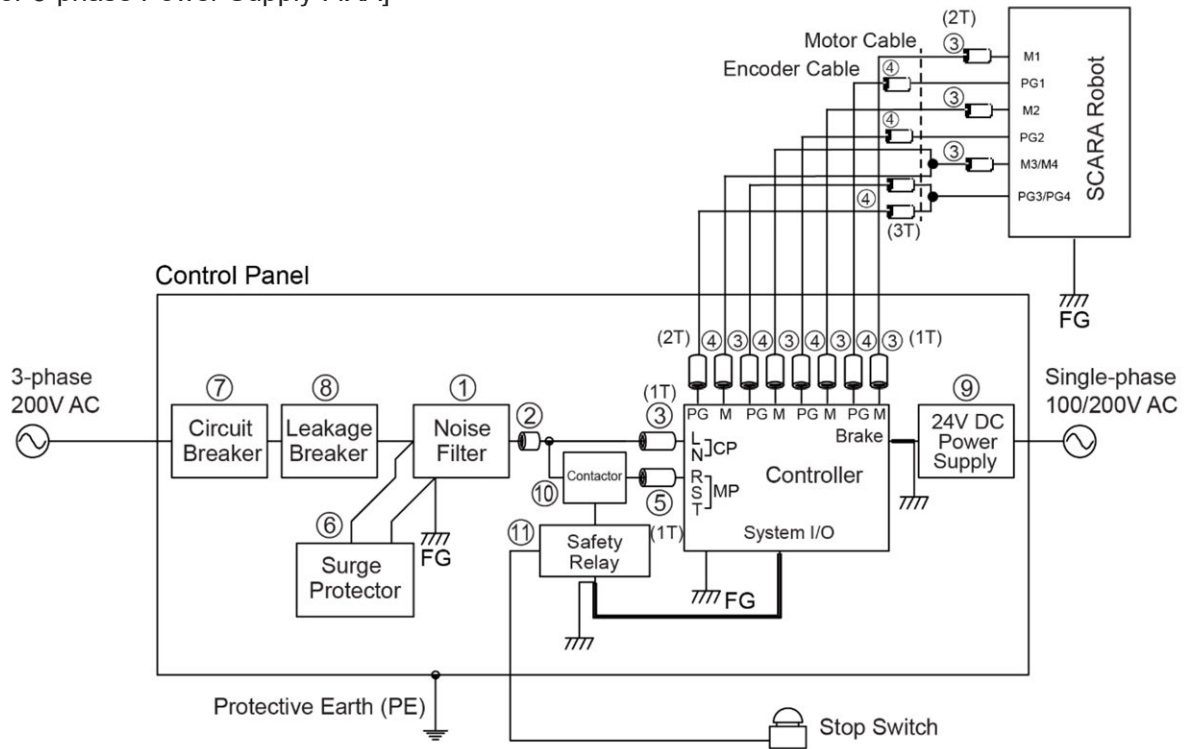

[For 3-phase Power Supply : IXA (XSEL-SAX4\_high capacity types)]

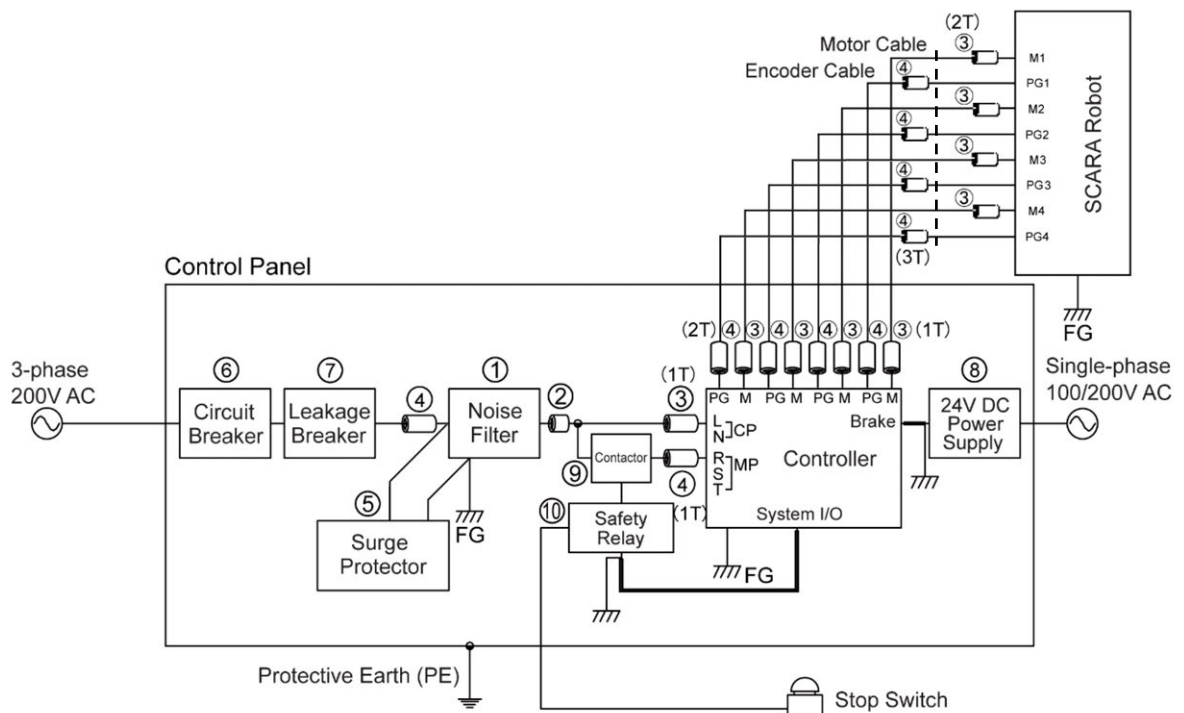

[Examples of components for EMC counteraction and protection devices and power source to ensure safety]

## ● IX

No.	Name	Model	Supplier	Quantity	Remarks
①	Noise Filter (1) *1	TAC-20-683	COSEL	1	For 3-phase power supply type
		NF3020C-SVA	Soshin Electronics Co., Ltd		
	Noise Filter (2) *2	NBH-20-432	COSEL	1	For Single-phase power supply type
		SUP-EL20-ER-6	OKAYA Electric Industries Co., Ltd.		
②	Ring Core	ESD-R-25	TOKIN Corporation	1	
③	Clamp Filter (1)	ZCAT3035-1330	TDK Corporation	6	
④	Clamp Filter (3)	RFC-H13	Kitagawa Industries Co., Ltd	1	
⑤	Surge Protector (3)	R•A•V -781BXZ-4	OKAYA Electric Industries Co., Ltd.	1	For 3-phase power supply type
	Surge Protector (1)	R•A•V -781BWZ-2A	OKAYA Electric Industries Co., Ltd.	1	For Single-phase power supply type
⑥	Circuit Breaker (1)	NF32-SVF-3P-15A	Mitsubishi Electric Corporation	1	100V/200V AC Input in common
⑦	Leakage Breaker (1)	NV32-SVF-3P-15A-AC100-240V-30mA-CE•CCC	Mitsubishi Electric Corporation	1	100V/200V AC Input in common
⑧	24V DC Power Supply (2)	ZWS75BAF-24	TDK-Lambda Corporation	1	100V/200V AC Input in common
⑨	Contactator (1)	SC-0/G	Fuji Electric Co., Ltd.	1×Number of Axes	
⑩	Safety Relay (1)	G9SA-301	OMRON	1×Number of Axes	

\* The number in the brackets shows the part number described below.

\*1 Select from either TAC-20-683 (COSEL) or NF3020C-SVA (Soshin Electronics Co., Ltd) for Noise Filter (1).

\*2 Select from either NBH-20-432 (COSEL) or SUP-EL20-ER-6 (OKAYA Electric Industries Co., Ltd.) for Noise Filter (2).

## ● IXA

No.	Name	Model	Supplier	Quantity	Remarks
①	Noise Filter (1) *1	TAC-20-683	COSEL	1	
		NF3020C-SVA	Soshin Electronics Co., Ltd		
②	Ring Core	ESD-R-25	TOKIN Corporation	1	
③	Clamp Filter (1)	ZCAT3035-1330	TDK Corporation	8	
④	Clamp Filter (2)	E04SR401938	SEIWA Electronics Co., Ltd	7	
⑤	Clamp Filter (3)	RFC-H13	Kitagawa Industries Co., Ltd	1	
⑥	Surge Protector (3)	R•A•V-781BXZ-4	OKAYA Electric Industries Co., Ltd.	1	
⑦	Circuit Breaker (1)	NF32-SVF-3P-15A	Mitsubishi Electric Corporation	1	
⑧	Leakage Breaker (1)	NV32-SVF-3P-15A-AC100-240V-30mA-CE•CCC	Mitsubishi Electric Corporation	1	
⑨	24V DC Power Supply (4)	S8JX-N15024C	OMRON	1	
⑩	Contactora (1)	SC-0/G	Fuji Electric Co., Ltd.	1×Number of Axes	
⑪	Safety Relay (1)	G9SA-301	OMRON	1×Number of Axes	

\* The number in the brackets shows the part number described below.

\*1 Select from either TAC-20-683 (COSEL) or NF3020C-SVA (Soshin Electronics Co., Ltd) for Noise Filter (1).

## ● IXA (high capacity types)

No.	Name	Model	Supplier	Quantity	Remarks
①	Noise Filter (5)	NF3030C-SVF	Soshin Electronics Co., Ltd	1	
②	Ring Core	ESD-R-25	TOKIN Corporation	1	
③	Clamp Filter (1)	ZCAT3035-1330	TDK Corporation	8	
④	Clamp Filter (2)	E04SR401938	SEIWA Electronics Co., Ltd	10	
⑤	Surge Protector (3)	R•A•V-781BXZ-4	OKAYA Electric Industries Co., Ltd.	1	
⑥	Circuit Breaker (1)	NF32-SVF-3P-30A	Mitsubishi Electric Corporation	1	
⑦	Leakage Breaker (1)	NV32-SVF-3P-30A-AC100-240V-30mA-CE•CCC	Mitsubishi Electric Corporation	1	
⑧	24V DC Power Supply (4)	ZWS75BAF-24	TDK-Lambda Corporation	1	
⑨	Contactora (1)	SC-0/G	Fuji Electric Co., Ltd.	1×Number of Axes	
⑩	Safety Relay (1)	G9SA-301	OMRON	1×Number of Axes	

\* The number in the brackets shows the part number described below.

Mount the clamp filter as close to the cable terminal as possible, and affix with a zip ties so it would not move.

Have the motor cable go through in a clamp filter on both the actuator and the controller ends.

On the actuator side, the motor cable is integrated to one, thus put that cable straight into the clamp filter. It is not necessary to have a clamp filter on the encoder cable.

For the power cable, separate into motor power lines (1Ph: MP-L and N, 3Ph: MP-R, S and T) and control power lines (1Ph / 3Ph: CP-L and N) and put each bundle through the cable clamps.

Put the motor and control power lines together and put it through a ring core.

Attach a noise filter to the point where the cable length is 300mm or less from the controller.

For the brake power supply cable, use a shielded 2-core (1-paired) twisted cable with AWG16 to 20 (1.25 to 0.5mm<sup>2</sup>), and ground the shield on the 24V DC power supply side.

For the cable to connect the safety relay unit and the system I/O, use a shielded 9-paired (or more) twisted cable with AWG16 to 24, and ground the shield on the safety relay unit side.

The circuit breaker, leakage breaker and 24V DC power supply are the delegated samples.

When choosing a circuit breaker, choose one that the cutoff current would not trip with the in-rush current.

Choose a harmonic and surge-applicable type for the leakage breaker.

Choose a CE complied type that is safety-insulated one for the 24V DC power supply.

XSEL QX/SAX type Controller does not possess the drive cutoff circuit inside so a free construction of the safety circuit (Ⓢ Contactor • Ⓢ Safety Relay) suitable for the structure of your equipment can be built outside the controller.

Construct a safety circuit following the instruction manual of the applicable XSEL Controller before start using. Also, as the protection devices listed in the list may not be used, refer to the [instruction manual of the applicable XSEL Controller] and choose the appropriate protection device.

2.8.16 TTA

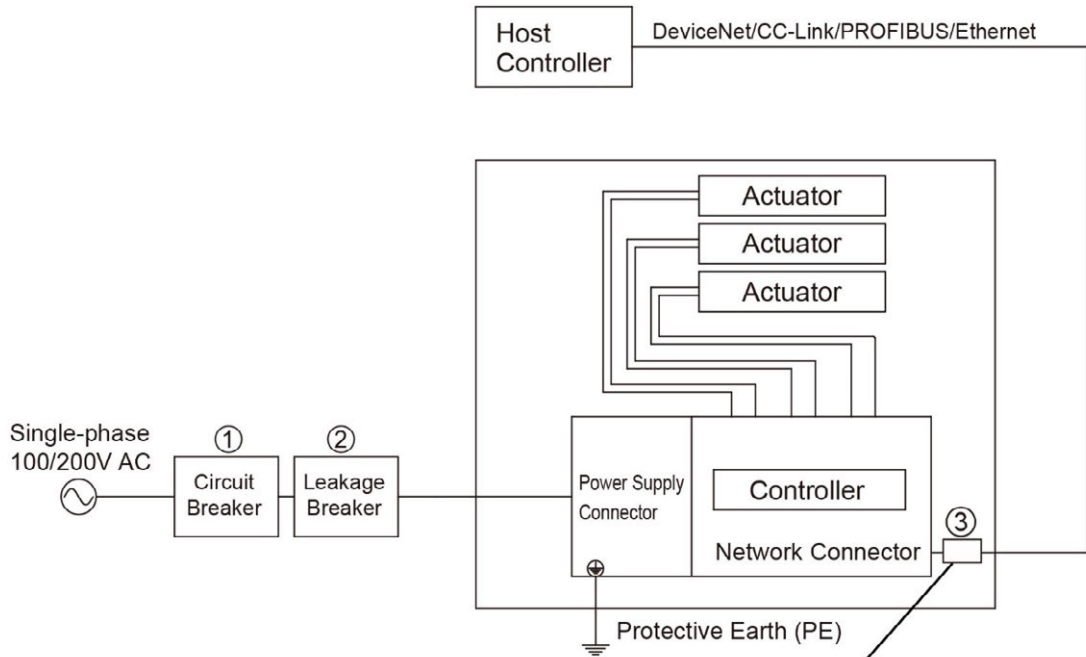

Apply a clamp filter for one turn for EtherNet/IP type of TTA.

\* The diagram above shows that for 3-axis type. Have the same treatment also for 2-axis type and 4-axis type.

[Examples of component for protection devices to ensure safety]

No.	Name	Model	Supplier	Quantity	Remarks
①	Circuit Breaker (1)	NF32-SVF-3P-15A	Mitsubishi Electric Corporation	1	100V/200V AC Input in common
②	Leakage Breaker (1)	NV32-SVF-3P-15A-AC100-240V-30mA-CE•CCC	Mitsubishi Electric Corporation	1	100V/200V AC Input in common
③	Clamp Filter (1)	ZCAT3035-1330	TDK Corporation	1	

\* The number in the brackets shows the part number described below.

2.8.17 ERC/ERC2/ERC3

[SIO]

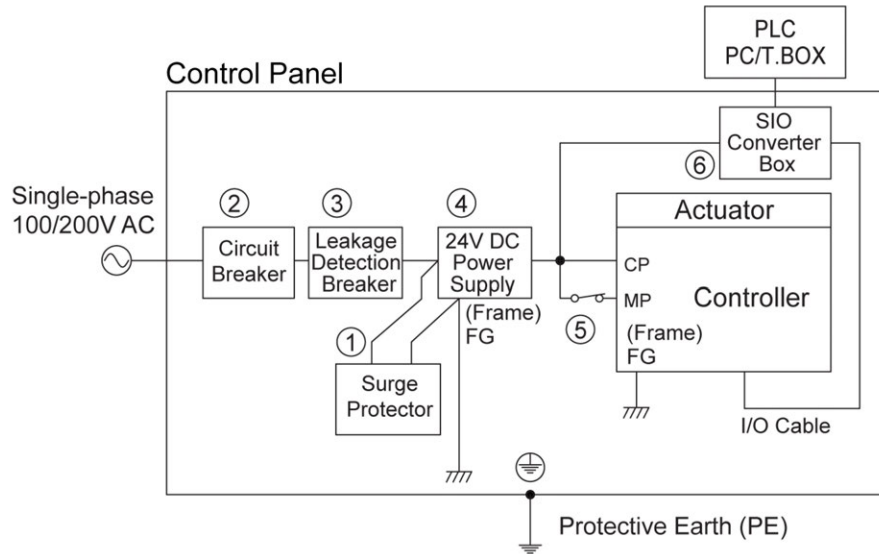

[PIO]

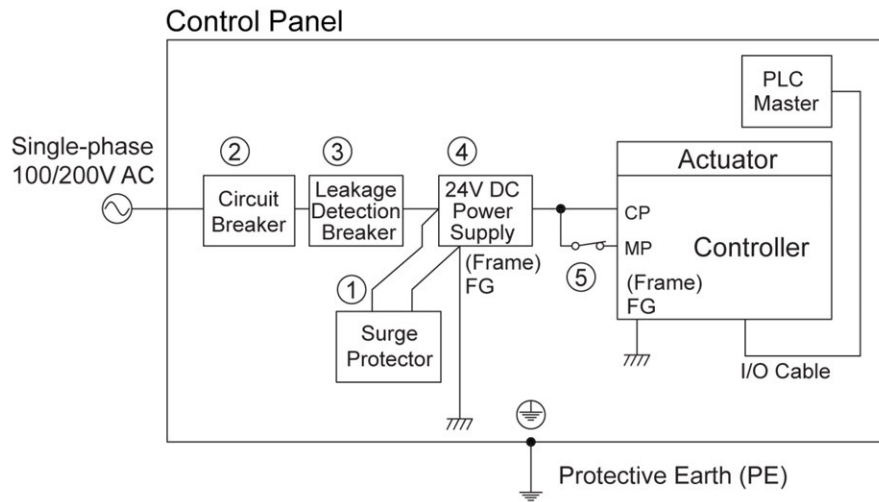

[Examples of component for protection devices to ensure safety]

No.	Name	Model	Supplier	Quantity	Remarks
①	Surge Protector (2)	R•A•V-781BWZ-2A	OKAYA Electric Industries Co., Ltd.	1	
②	Circuit Breaker (1)	NF32-SVF-3P-15A	Mitsubishi Electric Corporation	1	100V/200V AC Input in common
③	Leakage Breaker (1)	NV32-SVF-2P-15A-AC100-240V-30mA-CE•CCC	Mitsubishi Electric Corporation	1	100V/200V AC Input in common
④	24V DC Power Supply (1)	ZWS150BAF-24	TDK-Lambda Corporation	1	100V/200V AC Input in common
⑤	Relay	LY Series	OMRON	1	
		HC Relay Series	Panasonic Electric Works Co., Ltd.	(1)	
⑥	SIO Converter	RCB-TU-SIO-A(B)	IAI	1	

\* The number in the brackets shows the part number described below.

The circuit breaker, leakage breaker and 24V DC power supply are the delegated samples.

When choosing a circuit breaker, choose one that the cutoff current would not trip with the in-rush current.

Choose a harmonic and surge-applicable type for the leakage breaker.

Choose a CE complied type that is safety-insulated one for the 24V DC power supply.

In the actual use, the setting will vary depending on the capacity of the combined actuator. Choose the appropriate equipment following refer to [the instruction manual of each model].

2.8.18 MSEL-PC/PG/PCF/PGF

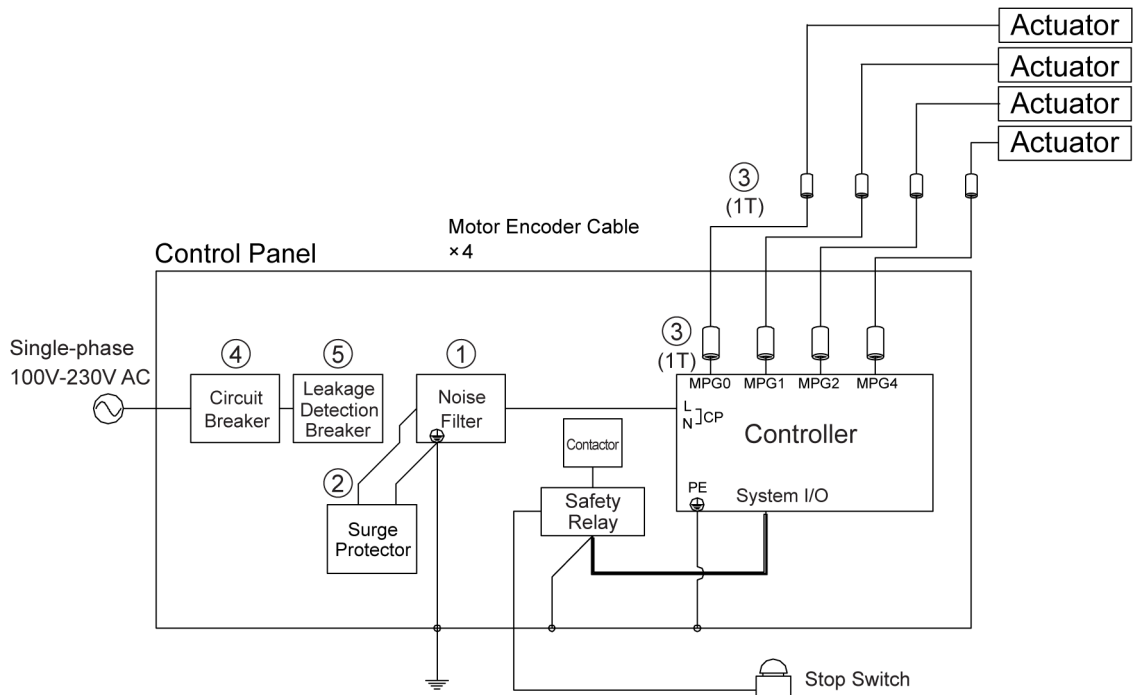

[Examples of component for protection devices to ensure safety]

No.	Name	Model	Supplier	Quantity	Remarks
①	Noise Filter (3) *1	NAC-10-472	COSEL	1	
		NF2010A-UP	Soshin Electronics Co., Ltd		
②	Surge Protector (1)	R•A•V-781BWZ-2A	OKAYA Electric Industries Co., Ltd.	-	It is not always necessary to install it, but it is recommended to do so.
③	Clamp Filter (1)	ZCAT3035-1330	TDK Corporation	2×Number of Axes	
④	Circuit Breaker (1)	NF32-SVF-3P-15A	Mitsubishi Electric Corporation	1	100V/200V AC Input in common
⑤	Leakage Breaker (1)	NV32-SVF-2P-15A-AC100-240V-30mA-CE•CCC	Mitsubishi Electric Corporation	1	100V/200V AC Input in common

\* The number in the brackets shows the part number described below.

\*1 Select from either NAC-10-472 (COSEL) or NF2010A-UP (Soshin Electronics Co., Ltd) for Noise Filter (3).

Mount Clamp Filters ③ as close to the both ends (1T turns on actuator end / 1T turn on controller end) of the motor and encoder cable as possible, and affix with a zip ties so it would not move.

Make sure to have PE terminal on the controller connected with a strand with size of 1.25-0.5mm<sup>2</sup> (AWG16-20) to the main frame of the controller panel.

Attach Noise Filter ① to a position that makes the cable length 300mm or less from the controller. Circuit Breaker ④ and Leakage Breaker ⑤ are representative examples.

When choosing a circuit breaker, choose one that the cutoff current would not trip with the in-rush current.

Select a leakage breaker that is applicable for higher harmonic wave and surge.

2.8.19 MSEL-PGX

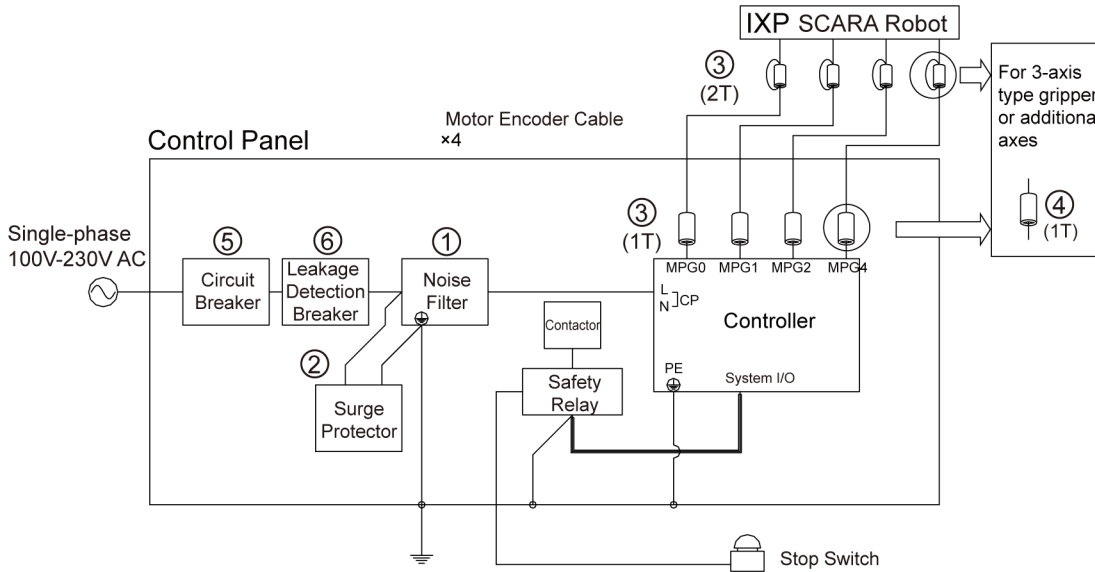

[Examples of components for EMC counteraction and protection devices and power source to ensure safety]

No.	Name	Model	Supplier	Quantity	Remarks
①	Noise Filter (3) *1	NAC-10-472	COSEL	1	
		NF2010A-UP	Soshin Electronics Co., Ltd		
②	Surge Protector (1)	R•A•V-781BWZ-2A	OKAYA Electric Industries Co., Ltd.	-	It is not always necessary to install it, but it is recommended to do so.
③	Clamp Filter (3)	E04SR401938	SEIWA Electronics Co., Ltd	3-axis type : 6 4-axis type : 8	SCARA robot
④	Clamp Filter (1)	ZCAT3035-1330	TDK Corporation	2	Gripper or additional axes
⑤	Circuit Breaker (1)	NF32-SVF-3P-15A	Mitsubishi Electric Corporation	1	100V/200V AC Input in common
⑥	Leakage Breaker (1)	NV32-SVF-2P-15A-AC100-240V-30mA-CE•CCC	Mitsubishi Electric Corporation	1	100V/200V AC Input in common

\* The number in the brackets shows the part number described below.

\*1 Select from either NAC-10-472 (COSEL) or NF2010A-UP (Soshin Electronics Co., Ltd) for Noise Filter (3).

Mount Clamp Filters ③ as close to the both ends (2T turns on actuator end / 1T turn on controller end) of the motor and encoder cable as possible, and affix with a zip ties so it would not move. Make sure to have PE terminal on the controller connected with a strand with size of 1.25-0.5mm<sup>2</sup> (AWG16-20) to the main frame of the controller panel.

Attach Noise Filter ① to a position that makes the cable length 300mm or less from the controller. Circuit Breaker ⑤ and Leakage Breaker ⑥ are representative examples.

When choosing a circuit breaker, choose one that the cutoff current would not trip with the in-rush current.

Select a leakage breaker that is applicable for higher harmonic wave and surge.

2.8.20 RCON-GW/GWG

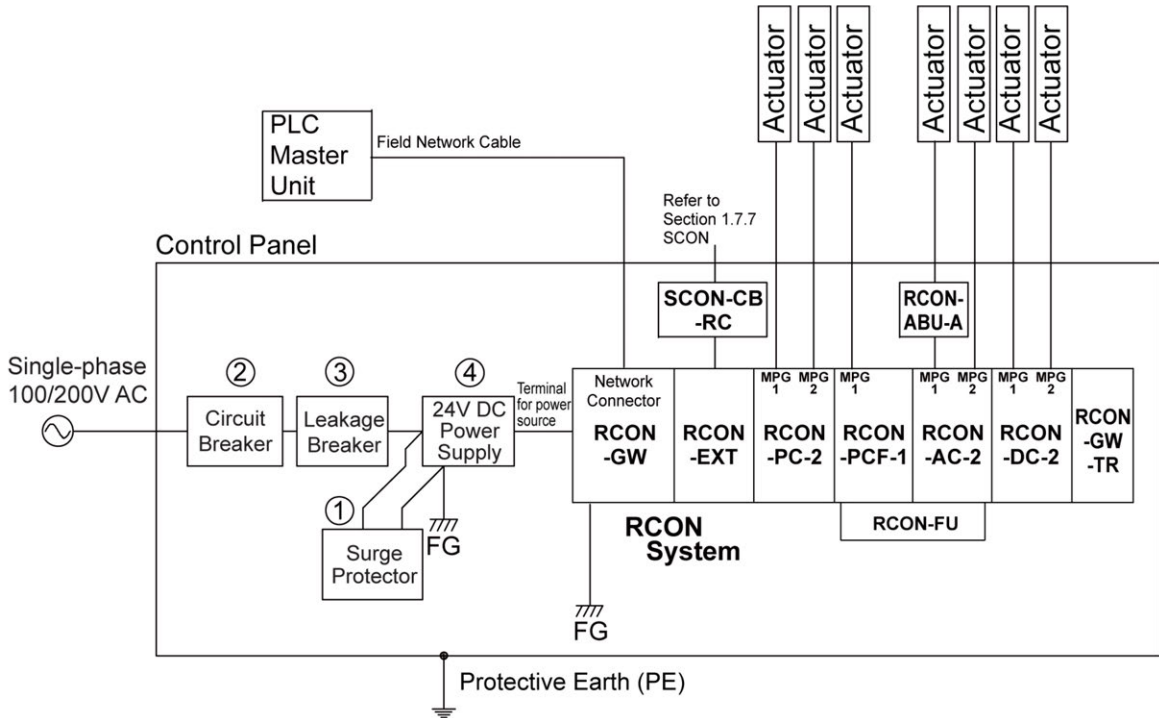

[Examples of components for EMC counteraction and protection devices and power source to ensure safety]

No.	Name	Model	Supplier	Quantity	Remarks
①	Surge Protector (1)	R•A•V-781BWZ-2A	OKAYA Electric Industries Co., Ltd.	1	
②	Circuit Breaker (1)	NF32-SVF-3P-15A	Mitsubishi Electric Corporation	1	100V/200V AC Input in common
③	Leakage Breaker (1)	NV32-SVF-2P-15A-AC100-240V-30mA-CE•CCC	Mitsubishi Electric Corporation	1	100V/200V AC Input in common
④	24V DC Power Supply (5)	HWS1500-24	TDK-Lambda Corporation	1	100V/200V AC Input in common

\* The number in the brackets shows the part number described below.

The diagram below shows an example for a construction with one driver unit (RCON-PC/PCF/AC/DC), one SCON expansion unit (RCON-EXT), one simple absolute unit (RCON-ABU-A) and one fan unit (RCON-FU). The same process with no exception should be conducted no matter how many units there are in the construction.

The PIO/SIO/SCON expansion unit (RCON-EXT-NP/PN), PIO unit (RCON-NP/PN) and the simple absolute unit for pulse motor (RCON-ABU-P) also complies with EMC Directive.

The circuit breaker, leakage breaker and 24V DC power supply are the delegated samples. When choosing a circuit breaker, choose one that the cutoff current would not trip with the in-rush current.

Choose a harmonic and surge-applicable type for the leakage breaker.

Choose a CE complied type that is safety-insulated one for the 24V DC power supply.

In the actual use, the setting will vary depending on the capacity of the combined actuator. Choose the appropriate equipment following the [RCON System Instruction Manual (ME0384)].

2.8.21 RSEL-G

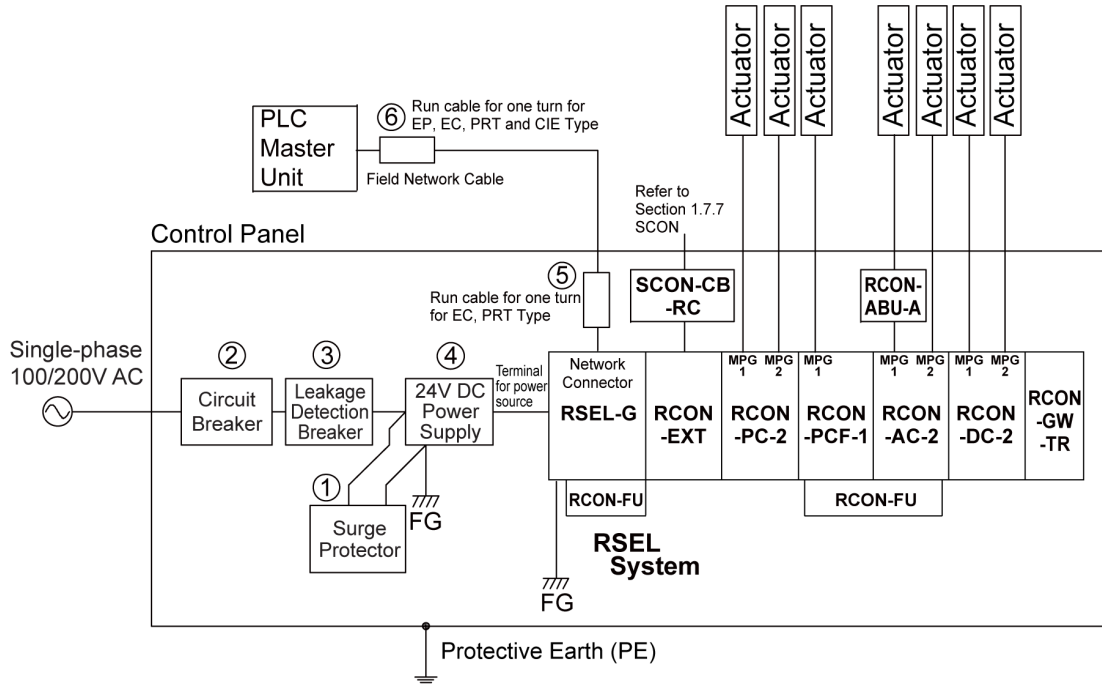

[Examples of components for EMC counteraction and protection devices and power source to ensure safety]

No.	Name	Model	Supplier	Quantity	Remarks
①	Surge Protector (1)	R•A•V-781BWZ-2A	OKAYA Electric Industries Co., Ltd.	1	
②	Circuit Breaker (1)	NF32-SVF-3P-15A	Mitsubishi Electric Corporation	1	100V/200V AC Input in common
③	Leakage Breaker (1)	NV32-SVF-2P-15A-AC100-240V-30mA-CE•CCC	Mitsubishi Electric Corporation	1	100V/200V AC Input in common
④	24V DC Power Supply (5)	HWS1500-24	TDK-Lambda Corporation	1	100V/200V AC Input in common
⑤	Clamp Filter (1)	ZCAT3035-1330	TDK Corporation	1	Only for EC and PRT
⑥	Clamp Filter (4)	E04SR211132	SEIWA Electronics Co., Ltd	1	Only for DSEP EP, EC, PRT and CIE type

\* The number in the brackets shows the part number described below.

The diagram below shows an example for a construction with one driver unit (RCON-PC/PCF/AC/DC), one SCON expansion unit (RCON-EXT), one simple absolute unit (RCON-ABU-A) and one fan unit (RCON-FU). The same process with no exception should be conducted no matter how many units there are in the construction.

The PIO/SIO/SCON expansion unit (RCON-EXT-NP/PN), PIO unit (RCON-NP/PN) and simple absolute unit for pulse motor (RCON-ABU-P) also complies with EMC Directive.

The circuit breaker, leakage breaker and 24V DC power supply are the delegated samples. When choosing a circuit breaker, choose one that the cutoff current would not trip with the in-rush current.

Choose a harmonic and surge-applicable type for the leakage breaker.

Choose a CE complied type that is safety-insulated one for the 24V DC power supply.

In the actual use, the setting will vary depending on the capacity of the combined actuator. Choose the appropriate equipment following the [RSEL System Instruction Manual (ME0392)].

2.8.22 RCON-SC

[For 3-phase Power Supply]

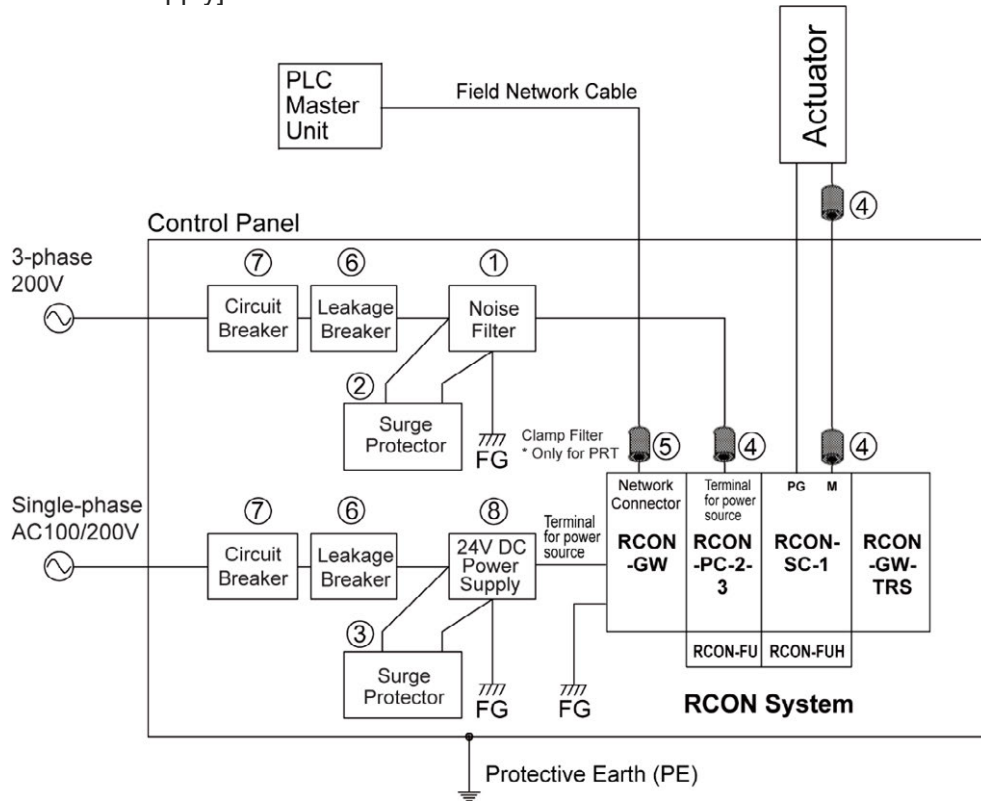

[For Single-phase Power Supply]

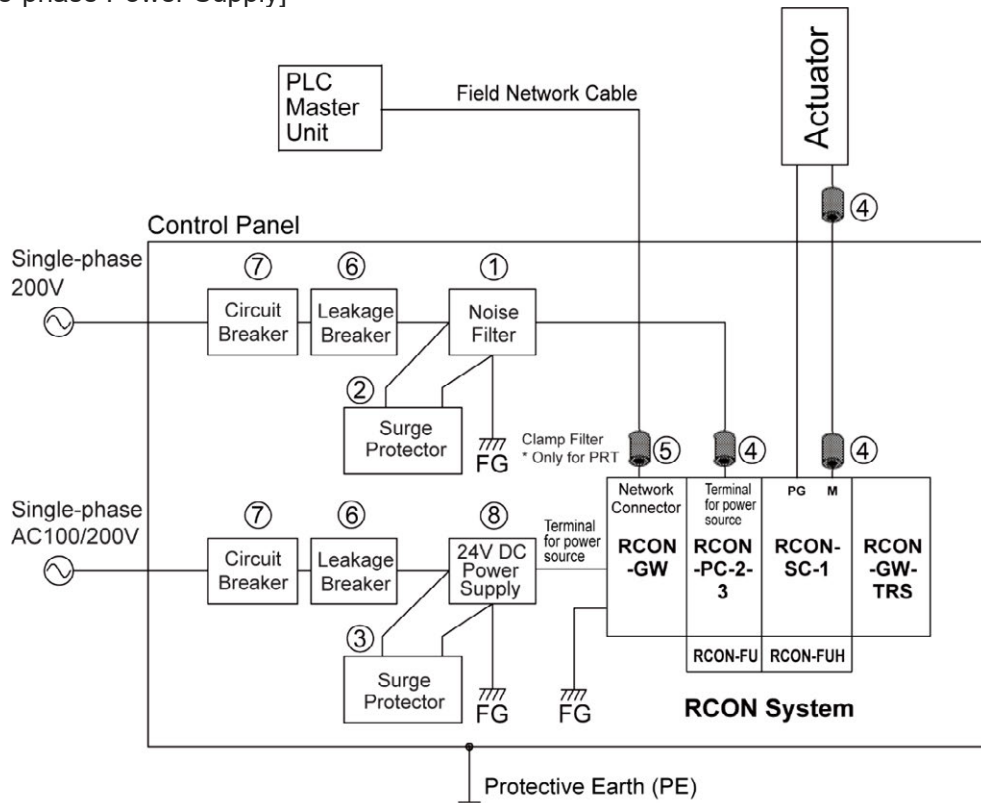

[Examples of components for EMC counteraction and protection devices and power source to ensure safety]

No.	Name	Model	Supplier	Quantity	Remarks
①	Noise Filter (2) *1	NBH-20-432	COSEL	1	For Single-phase power supply type
		SUP-EL20-ER-6	OKAYA Electric Industries Co., Ltd.		
	Noise Filter (1)	TAC-20-683	COSEL	1	For 3-phase power supply type
②	Surge Protector (1)	R•A•V-781BWZ-2A	OKAYA Electric Industries Co., Ltd.	1	For Single-phase power supply type
	Surge Protector (3)	R•A•V-781BXZ-4	OKAYA Electric Industries Co., Ltd.	1	For 3-phase power supply type
③	Surge Protector (1)	R•A•V-781BWZ-2A	OKAYA Electric Industries Co., Ltd.	1	
④	Clamp Filter (2)	E04SR401938	SEIWA Electronics Co., Ltd	3	
⑤	Clamp Filters (5)	ZCAT2032-0930	TDK Corporation	1	Used only in PRT Type
⑥	Leakage Breaker (1)	NV32-SVF-3P-15AAC100-240V-30mACE•CCC	Mitsubishi Electric Corporation	1	100V/200V AC Input in common
⑦	Circuit Breaker (1)	NF32-SVF-3P-15A	Mitsubishi Electric Corporation	1	100V/200V AC Input in common
⑧	24V DC Power Supply (6) *2	PSA-24	IAI	1	100V/200V AC Input in common

\* The number in the brackets shows the part number described below.

\*1 Select from either NBH-20-432 (COSEL) or SUP-EL20-ER-6 (OKAYA Electric Industries Co., Ltd.) for Noise Filter (2).

\*2 Refer to the [PSA-24 instruction Manual (ME0379)] for the details of PSA-24.

Shown in the figure above is an example of construction with one unit each of a gateway unit (RCON-GW), 200V power supply unit (RCON-PS2-3), 200V drive unit (RCON-SC-1), 200V terminal unit (RCON-GW-TRS) and fan unit (RCON-FU, RCON-FUH). Have the same measure no matter of the number of the units for construction.

Also, when RSEL-G is to be used instead of RCON-GW, follow the construction in [2.8.20 RSEL-G] for treatments.

The circuit breaker, leakage breaker and 24V DC power supply are the delegated samples.

When choosing a circuit breaker, choose one that the cutoff current would not trip with the in-rush current.

Choose a harmonic and surge-applicable type for the leakage breaker.

Choose a CE complied type that is safety-insulated one for the 24V DC power supply.

In the actual use, the setting will vary depending on the capacity of the combined actuator. Choose the appropriate equipment following the [RCON System Instruction Manual (ME0384)].

2.8.23 REC

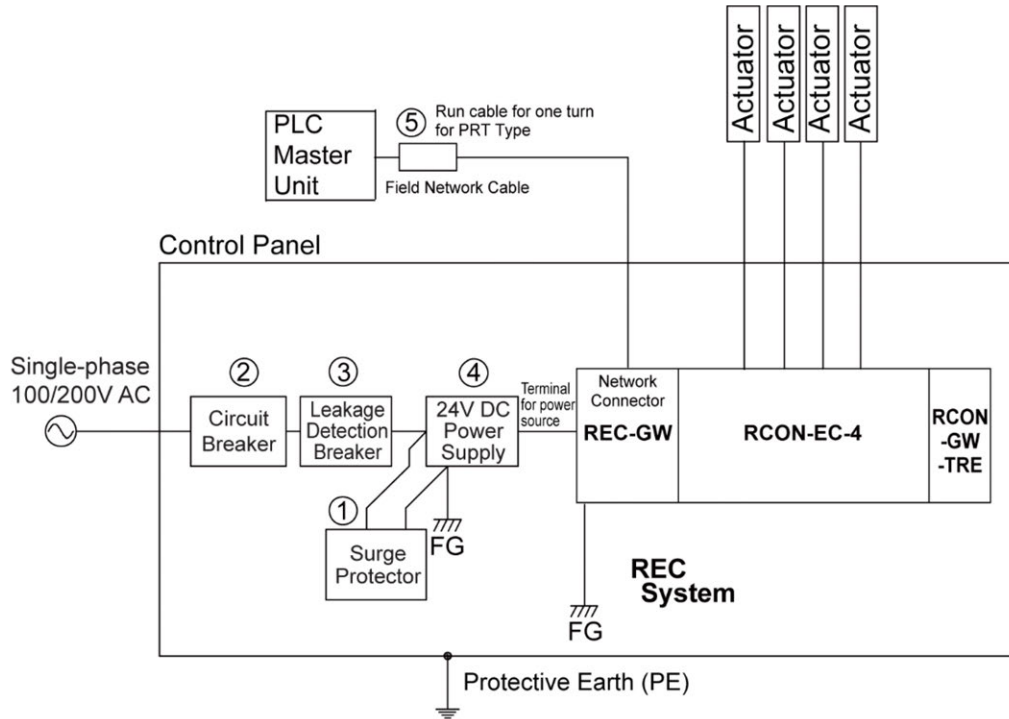

[Examples of components for EMC counteraction and protection devices and power source to ensure safety]

No.	Name	Model	Supplier	Quantity	Remarks
①	Surge Protector (1)	R•A•V-781BWZ-2A	OKAYA Electric Industries Co., Ltd.	1	
②	Circuit Breaker (1)	NF32-SVF-3P-15A	Mitsubishi Electric Corporation	1	100V/200V AC Input in common
③	Leakage Breaker (1)	NV32-SVF-2P-15A-AC100-240V-30mA-CE•CCC	Mitsubishi Electric Corporation	1	100V/200V AC Input in common
④	24V DC Power Supply	PSA-24 (*1)	IAI	1	100V/200V AC Input in common
⑤	Clamp Filter (5)	ZCAT2032-0930	TDK Corporation	1	Only for PRT

\* The number in the brackets shows the part number described below.

\*1 Refer to the [PSA-24 instruction Manual (ME0379)] for the details of PSA-24.

The circuit breaker, leakage breaker and 24V DC power supply are the delegated samples. When choosing a circuit breaker, choose one that the cutoff current would not trip with the in-rush current.

Choose a harmonic and surge-applicable type for the leakage breaker.

Choose a CE complied type that is safety-insulated one for the 24V DC power supply.

In the actual use, the setting will vary depending on the capacity of the combined actuator. Choose the appropriate equipment following the [REC System Instruction Manual (ME0394)].

2.8.24 ELECYLINDER

[Standard specifications]

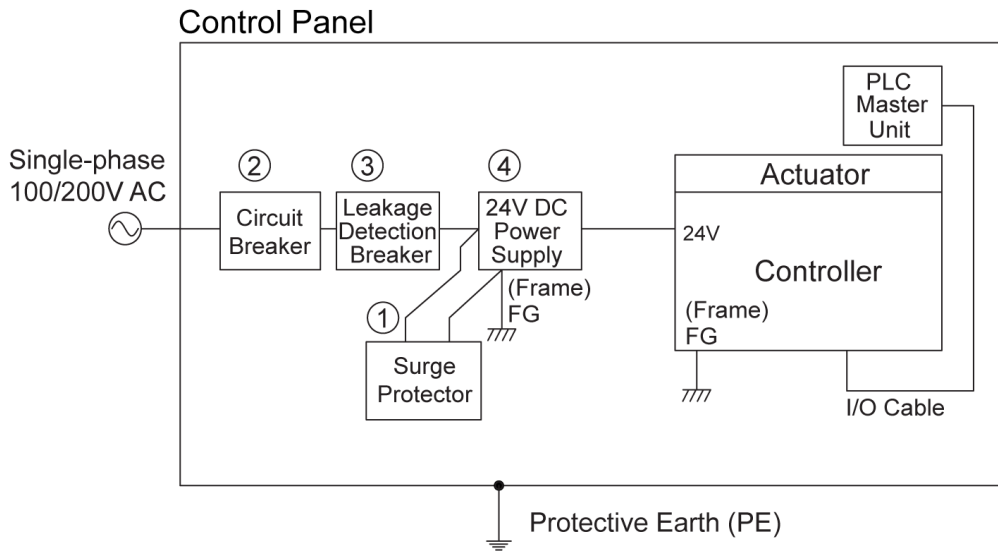

[TMD2 specifications]

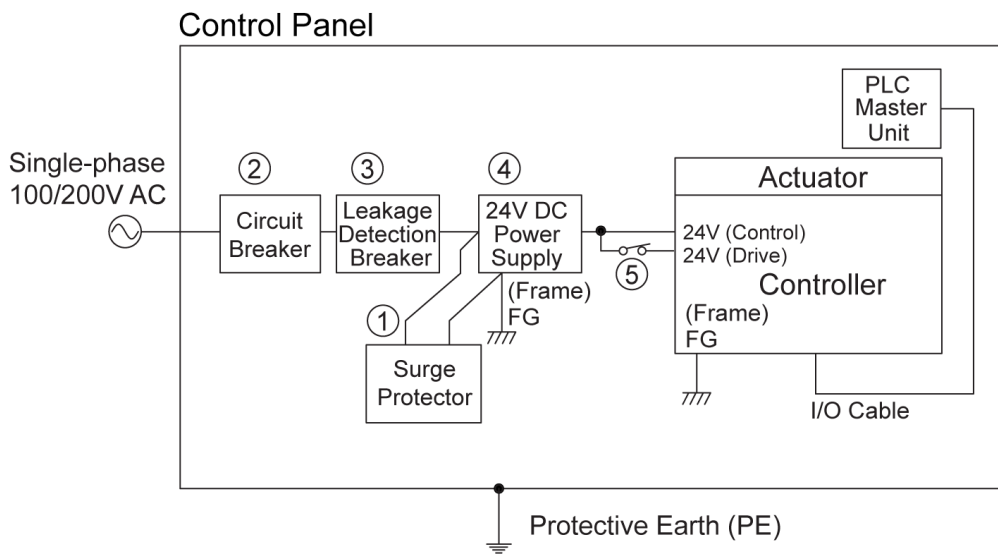

[Examples of components for EMC counteraction and protection devices and power source to ensure safety]

No.	Name	Model	Supplier	Quantity	Remarks
①	Surge Protector (2)	R•A•V-781BWZ-2A	OKAYA Electric Industries Co., Ltd.	1	
②	Circuit Breaker (1)	NF32-SVF-3P-15A	Mitsubishi Electric Corporation	1	100V/200V AC Input in common
③	Leakage Breaker (1)	NV32-SVF-2P-15A-AC100-240V-30mA-CE•CCC	Mitsubishi Electric Corporation	1	100V/200V AC Input in common
④	24V DC Power Supply (1)	ZWS150BAF-24	TDK-Lambda Corporation	1	100V/200V AC Input in common
⑤	Relay	LY Series	OMRON	1	
		HC Relay Series	Panasonic Electric Works Co., Ltd.	(1)	

\* The number in the brackets shows the part number described below.

The circuit breaker, leakage breaker and 24V DC power supply are the delegated samples. When choosing a circuit breaker, choose one that the cutoff current would not trip with the in-rush current.

Choose a harmonic and surge-applicable type for the leakage breaker.

Choose a CE complied type that is safety-insulated one for the 24V DC power supply.

In the actual use, the setting will vary depending on the capacity of the combined actuator.

Choose the appropriate equipment following the instruction manual of each model.

2.8.25 ELECYLINDER 200V

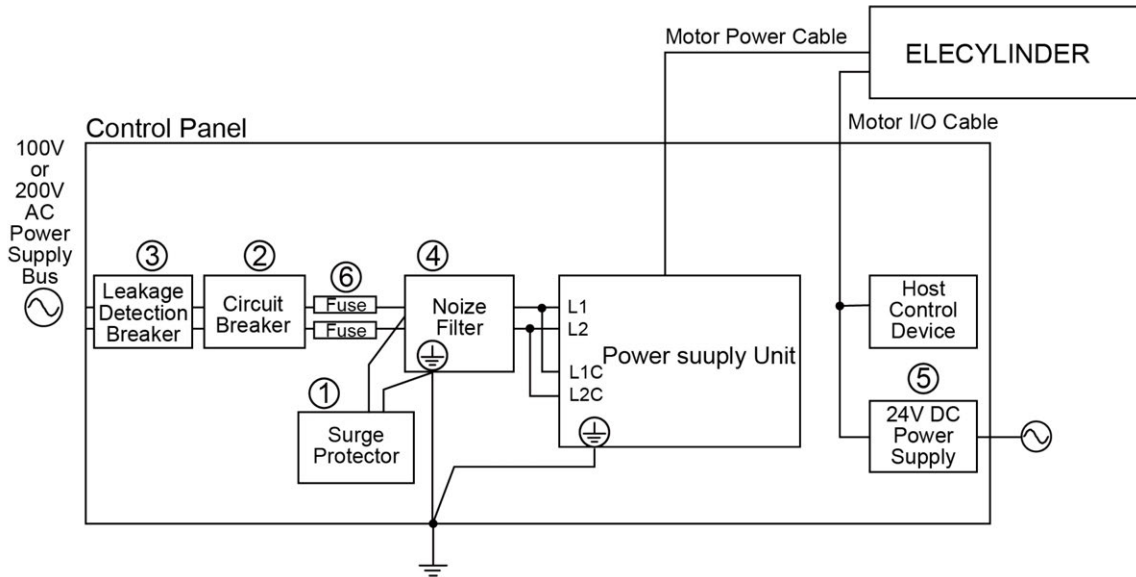

[Examples of components for EMC counteraction and protection devices and power source to ensure safety]

No.	Name	Model	Supplier	Quantity	Remarks
①	Surge Protector (2)	R•A•V-781BWZ-2A	OKAYA Electric Industries Co., Ltd.	1	
②	Circuit Breaker (1)	NF32-SVF-3P-20A	Mitsubishi Electric Corporation	1	100V/200V AC Input in common
③	Leakage Breaker (1)	NV32-SVF-2P-20A-AC100-240V-30mA-CE•CCC	Mitsubishi Electric Corporation	1	100V/200V AC Input in common
④	Noise Filter (3)	NAC-10-472	COSEL	1	
		or NF2010A-UP	Soshin Electronics Co., Ltd		
⑤	24V DC Power Supply (2)	ZWS75BAF-24	TDK-Lambda Corporation	1	100V/200V AC Input in common
⑥	Fuse (1)	CR2LS-20/UL	Fuji Electric Co., Ltd.	2	Necessary when used as UL certified Necessary to install to both L1 and L2

\* The number in the brackets shows the part number described below.

The circuit breaker, leakage breaker are the delegated samples.

When choosing a circuit breaker, choose one that the cutoff current would not trip with the in-rush current.

Choose a harmonic and surge-applicable type for the leakage breaker.

It is necessary to use a fuse when it is to be used as a UL certified product.

In the actual use, the setting will vary depending on the capacity of the combined actuator.

Choose the appropriate equipment following the instruction manual of each model.

2.8.26 ROBO PUMP

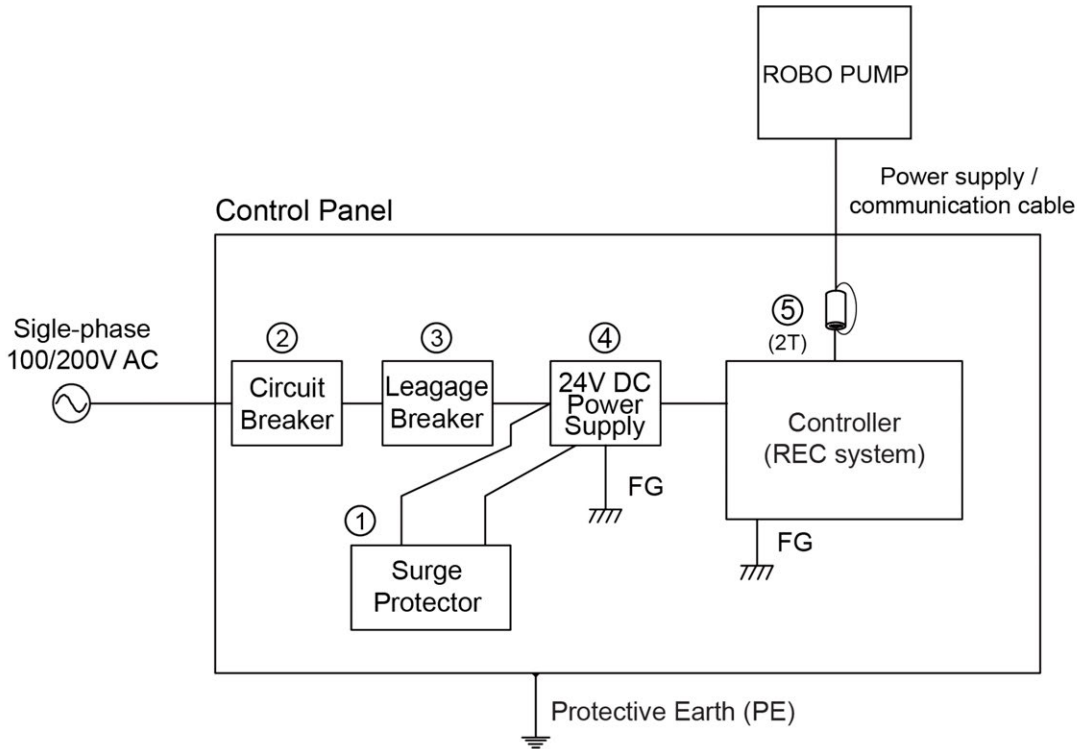

[Examples of components for EMC counteraction and protection devices and power source to ensure safety]

No.	Name	Model	Supplier	Quantity	Remarks
①	Surge Protector (1)	R•A•V-781BWZ-2A	OKAYA Electric Industries Co., Ltd.	1	
②	Circuit Breaker (1)	NF32-SVF-3P-15A	Mitsubishi Electric Corporation	1	100V/200V AC Input in common
③	Leakage Breaker (1)	NV32-SVF-2P-15A-AC100-240V-30mA-CE•CCC	Mitsubishi Electric Corporation	1	100V/200V AC Input in common
④	24V DC Power Supply	PSA-24 (*1)	IAI	1	100V/200V AC Input in common
⑤	Clamp Filter (1)	ZCAT3035-1330	TDK Corporation	1	

\* The number in the brackets shows the part number described below.

\*1 Refer to the [PSA-24 instruction Manual (ME0379)] for the details of PSA-24.

The circuit breaker, leakage breaker and 24V DC power supply are the delegated samples. When choosing a circuit breaker, choose one that the cutoff current would not trip with the in-rush current.

Choose a harmonic and surge-applicable type for the leakage breaker.

Choose a CE complied type that is safety-insulated one for the 24V DC power supply.

In the actual use, the setting will vary depending on the capacity of the combined actuator.

Choose the appropriate equipment following the instruction manual of each model.

2.8.27 On-Site Power Supply Unit

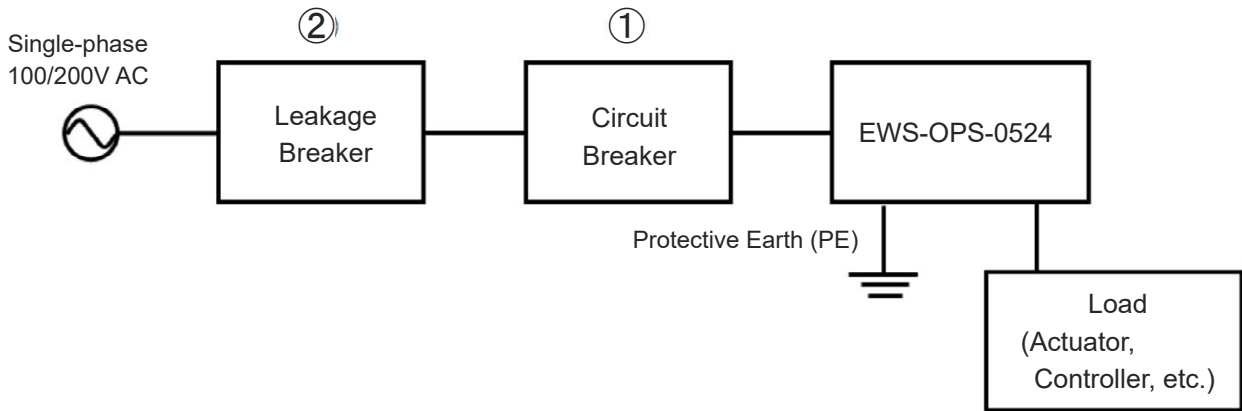

2: CE Marking

[Examples of components for EMC counteraction and protection devices and power source to ensure safety]

No.	Name	Model	Supplier	Quantity	Remarks
①	Circuit Breaker	QOU220	Schneider Electric	1	Necessary when used as UL certified
②	Leakage Breaker	NV32-SVF-2P-20A-AC100-240V-30mA-CE•CCC	Mitsubishi Electric Corporation	1	100V/200V AC Input in common

The leakage breaker is a delegated sample.

When choosing a circuit breaker, choose one that the cutoff current would not trip with the in-rush current.

It is necessary to use the circuit breaker of the above type when it is to be used as a UL certified product.

Choose a harmonic and surge-applicable type for the leakage breaker.

In the actual use, the setting will vary depending on the capacity of the combined actuator.

Choose the appropriate equipment following the instruction manual of each model.

2.8.28 e-Wiring System Connection Unit

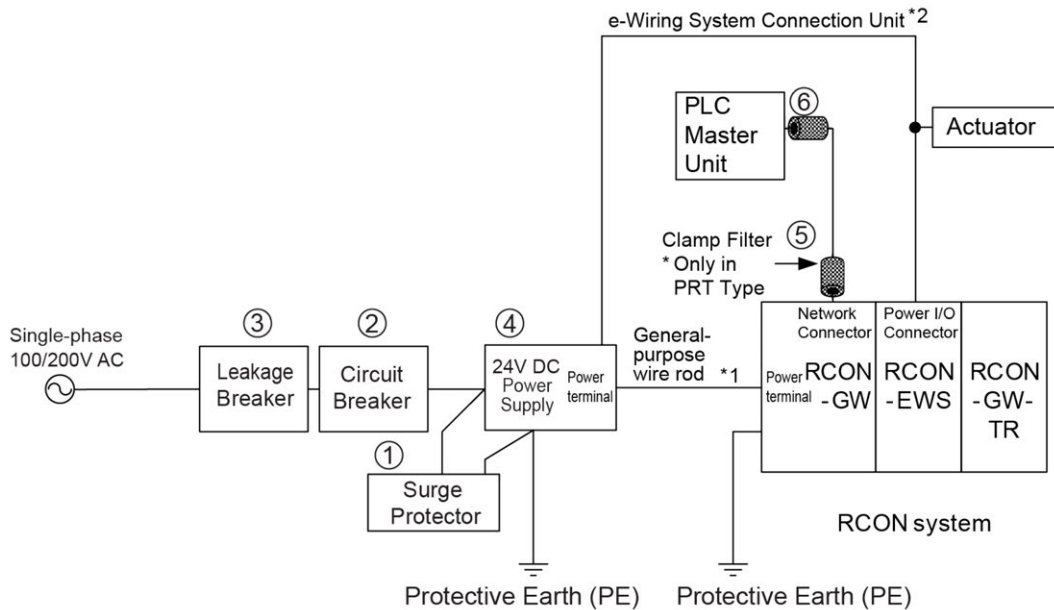

- \*1 When connecting power to RCON-GW
- \*2 When connecting power via the e-wiring system

o When using PSA-24/L

No.	Name	Model	Supplier	Quantity	Remarks
①	Surge Protector	R•A•V-781BWZ-2A	OKAYA Electric Industries Co., Ltd.	1	
②	Circuit Breaker	NF32-SVF-3P-15A	Mitsubishi Electric Corporation	1	100V/200V AC Input in common
③	Leakage Breaker	NV32-SVF-2P-15A-AC100-240V-30mA-CE•CCC	Mitsubishi Electric Corporation	1	100V/200V AC Input in common
④	24V DC Power Supply	PSA-24 (*1)	IAI	1	100V/200V AC Input in common
⑤	Clamp Filter	ZCAT2032-0930	TDK Corporation	1	Used only in PRT Type
⑥	Clamp Filter	ZCAT2032-0930	TDK Corporation	1	

o When to using EWS-OPS-0524

No.	Name	Model	Supplier	Quantity	Remarks
①	Surge Protector	R•A•V-781BWZ-2A	OKAYA Electric Industries Co., Ltd.	1	
②	Circuit Breaker	QOU220	Schneider Electric	1	100V/200V AC Input in common
③	Leakage Breaker	NV32-SVF-2P-20A-AC100-240V-30mA-CE•CCC	Mitsubishi Electric Corporation	1	100V/200V AC Input in common
④	24V DC Power Supply	EWS-OPS-0524	IAI	1	100V/200V AC Input in common
⑤	Clamp Filter	ZCAT3035-1330	TDK Corporation	1	Used only in PRT Type
⑥	Clamp Filter	ZCAT2032-0930	TDK Corporation	1	

The leakage breaker is a delegated sample.

When choosing a circuit breaker, choose one that the cutoff current would not trip with the in-rush current.

It is necessary to use the circuit breaker of the above type when it is to be used as a UL certified product.

Choose a harmonic and surge-applicable type for the leakage breaker.

In the actual use, the setting will vary depending on the capacity of the combined actuator.

Choose the appropriate equipment following the instruction manual of each model.

## 2.9 Components for EMC Counteraction

Introduced below are the components for EMC counteraction to be used for each model. To meet the EMC Directive, apply them to the appropriate points where the peripheral devices for each model indicate.

### 2.9.1 Clamp Filter

Clamp Filter (1)

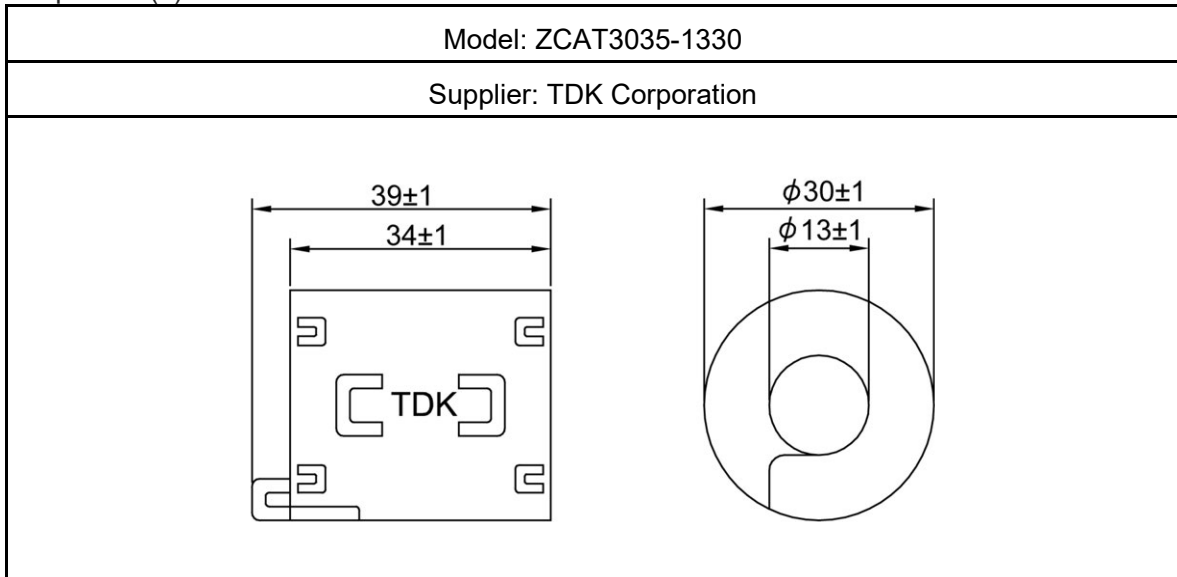

Clamp Filter (2)

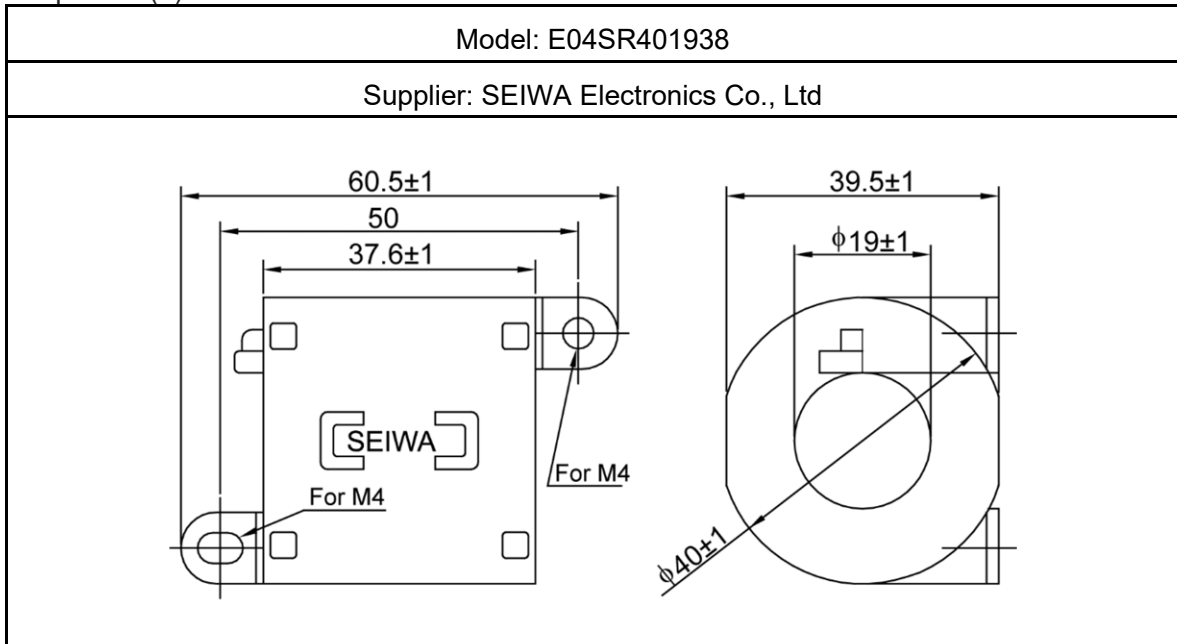

Clamp Filter (3)

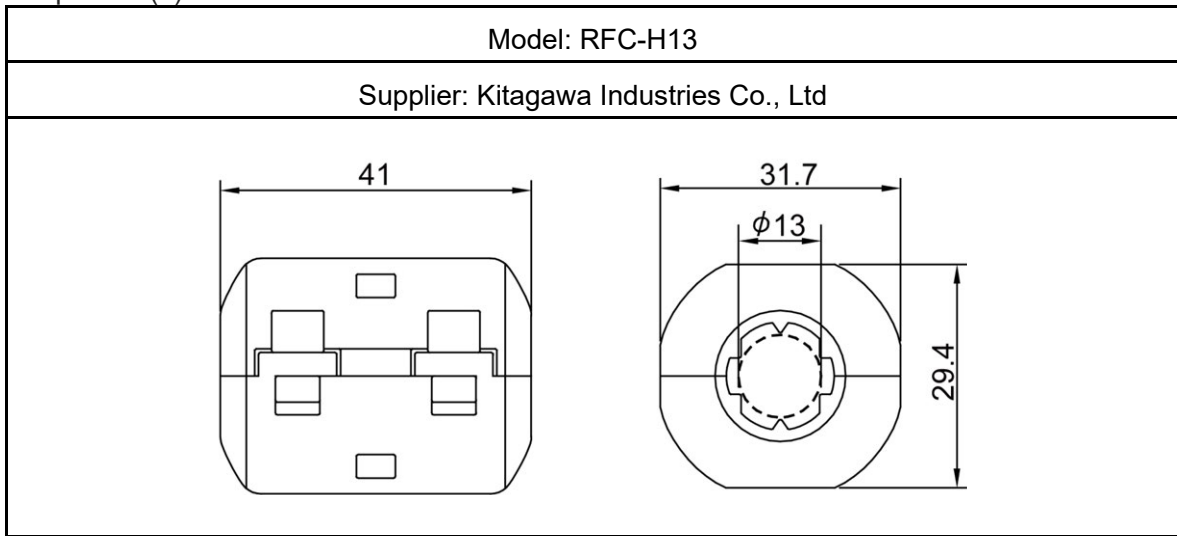

Clamp Filter (4)

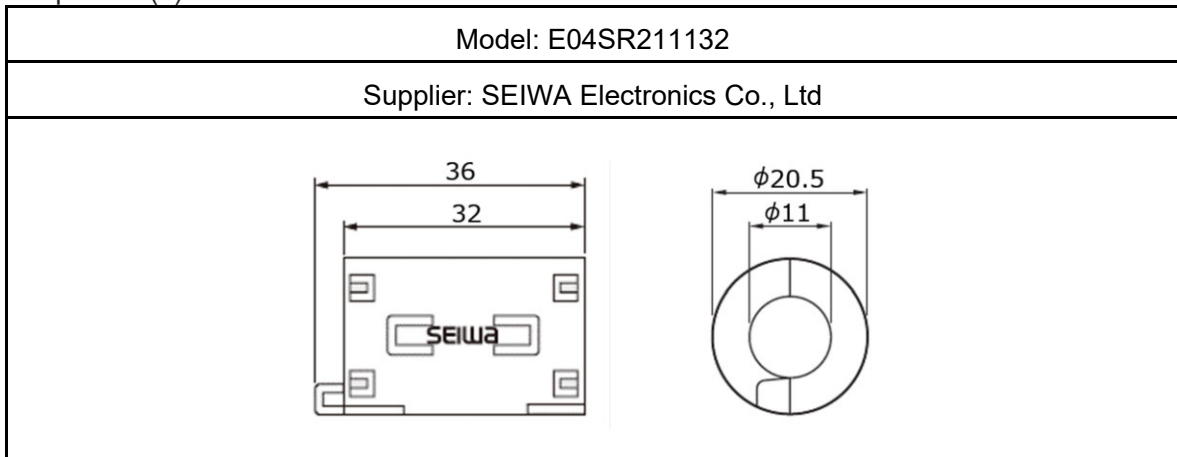

Clamp Filter (5)

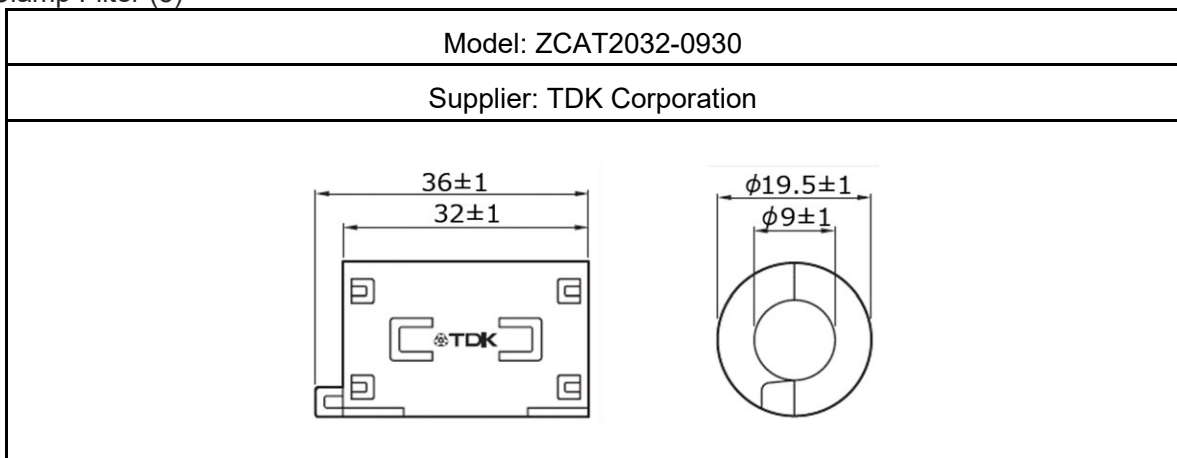

2.9.2 Ring Core

2. CE Marking

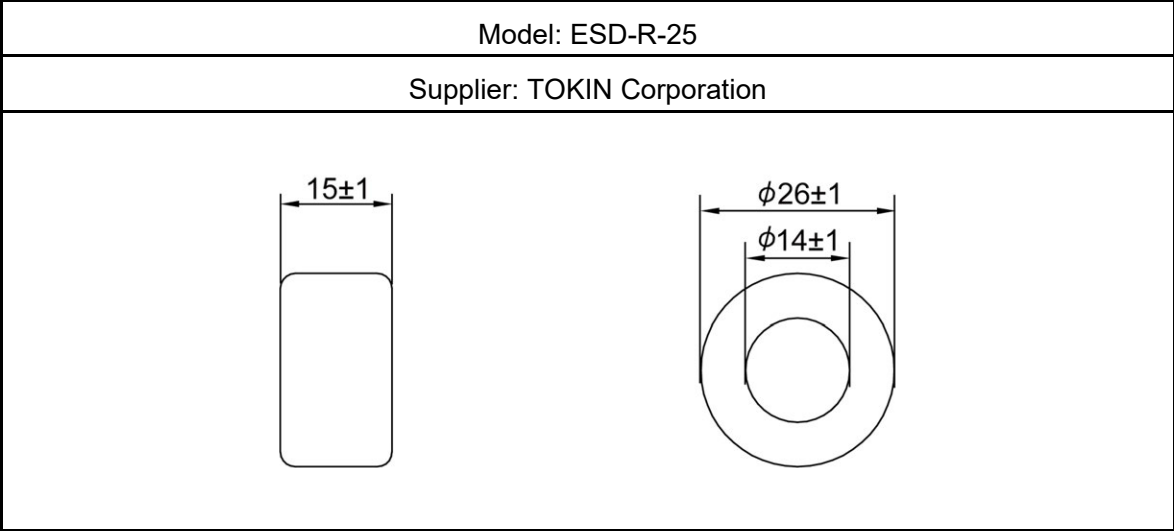

2.9.3 Noise Filter

Noise Filter (1)

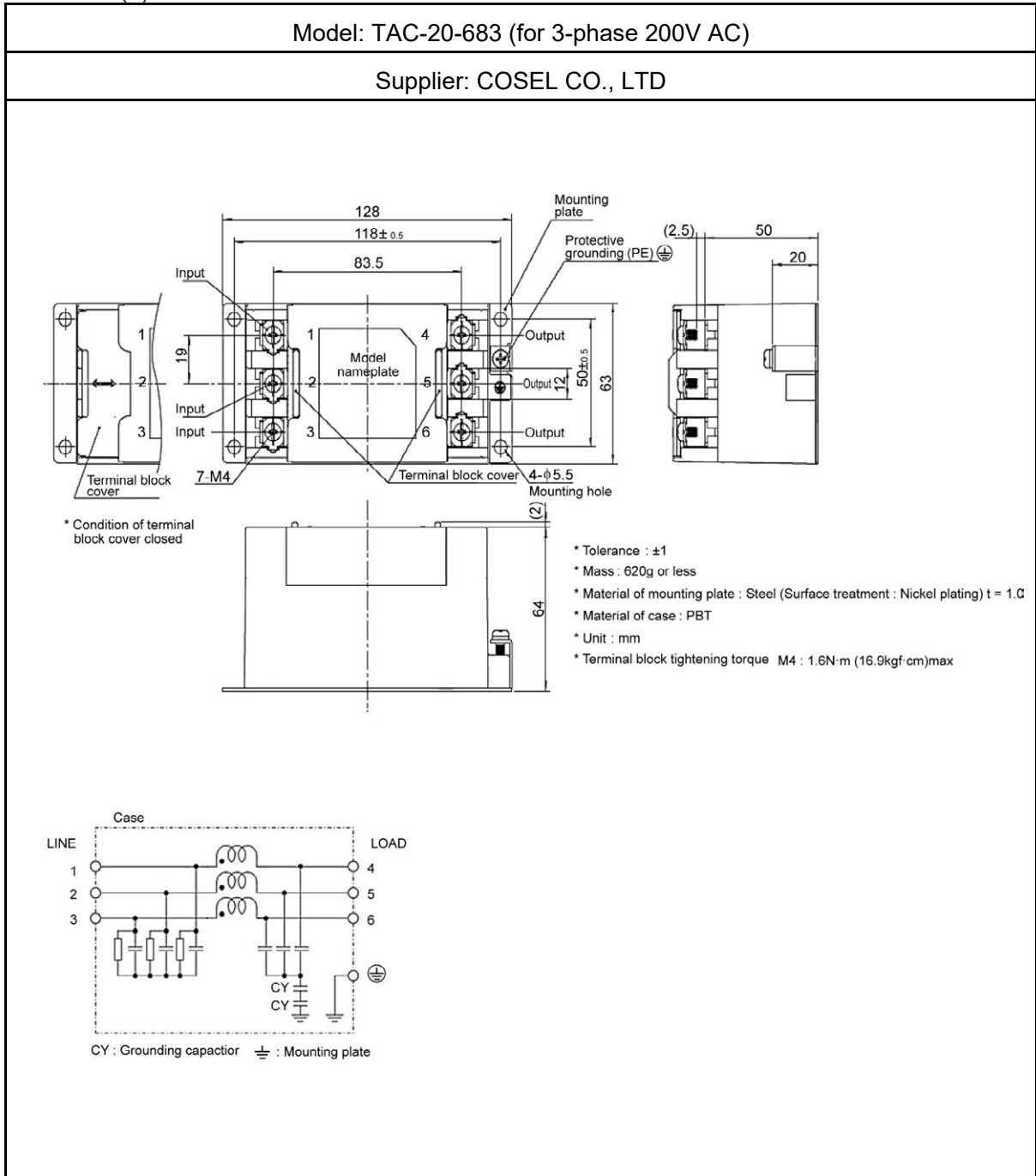

2: CE Marking

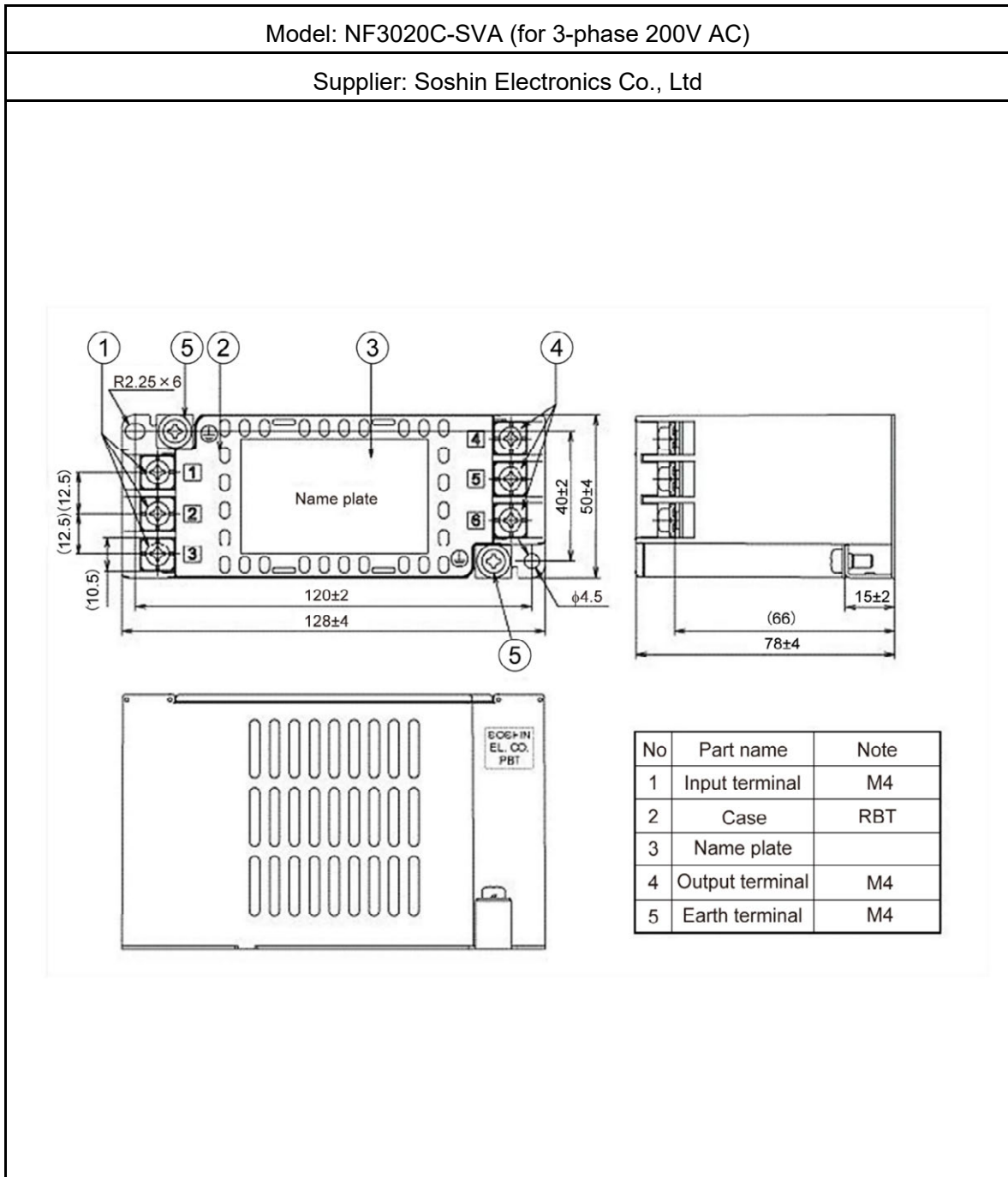

Noise Filter (2)

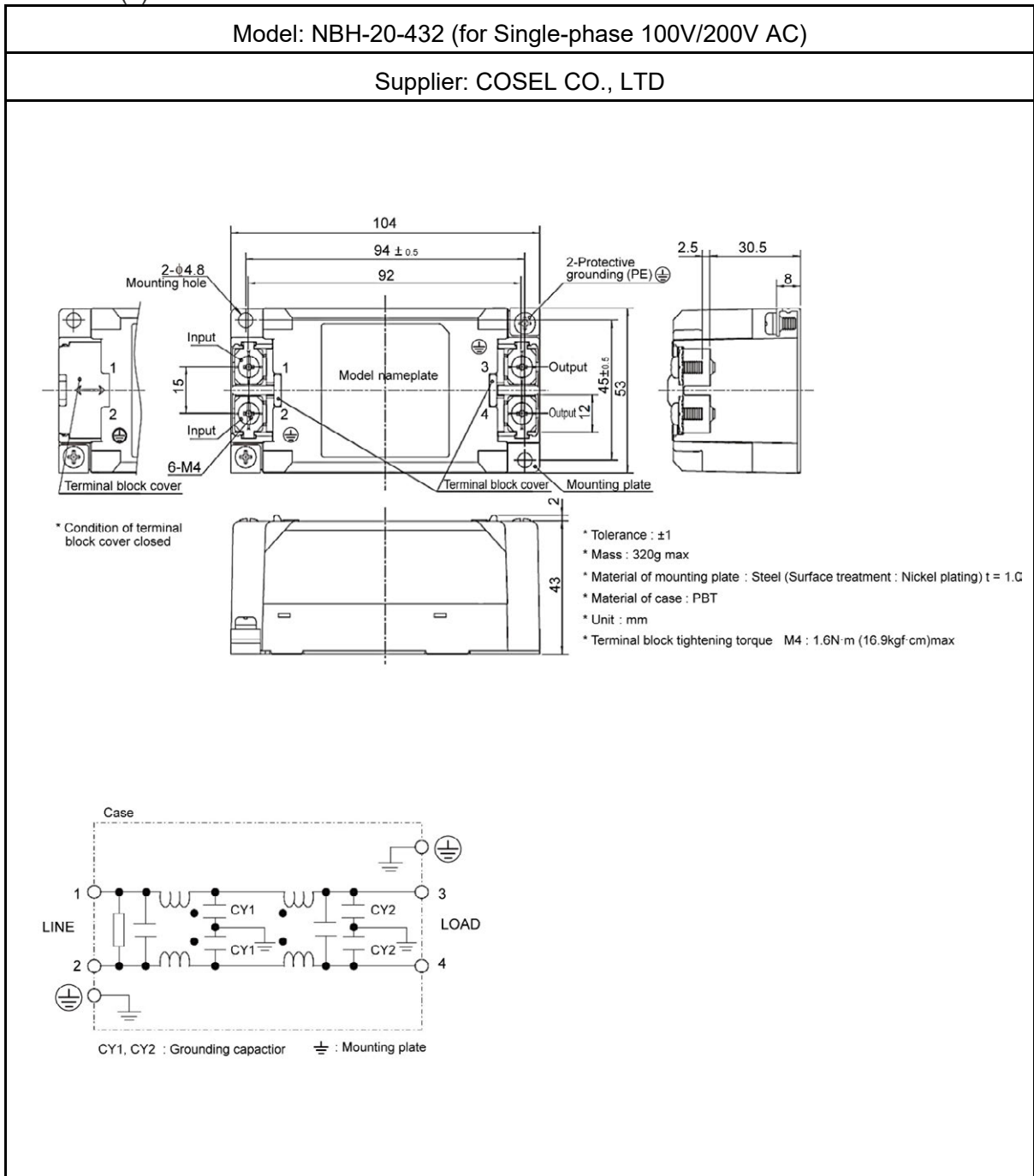

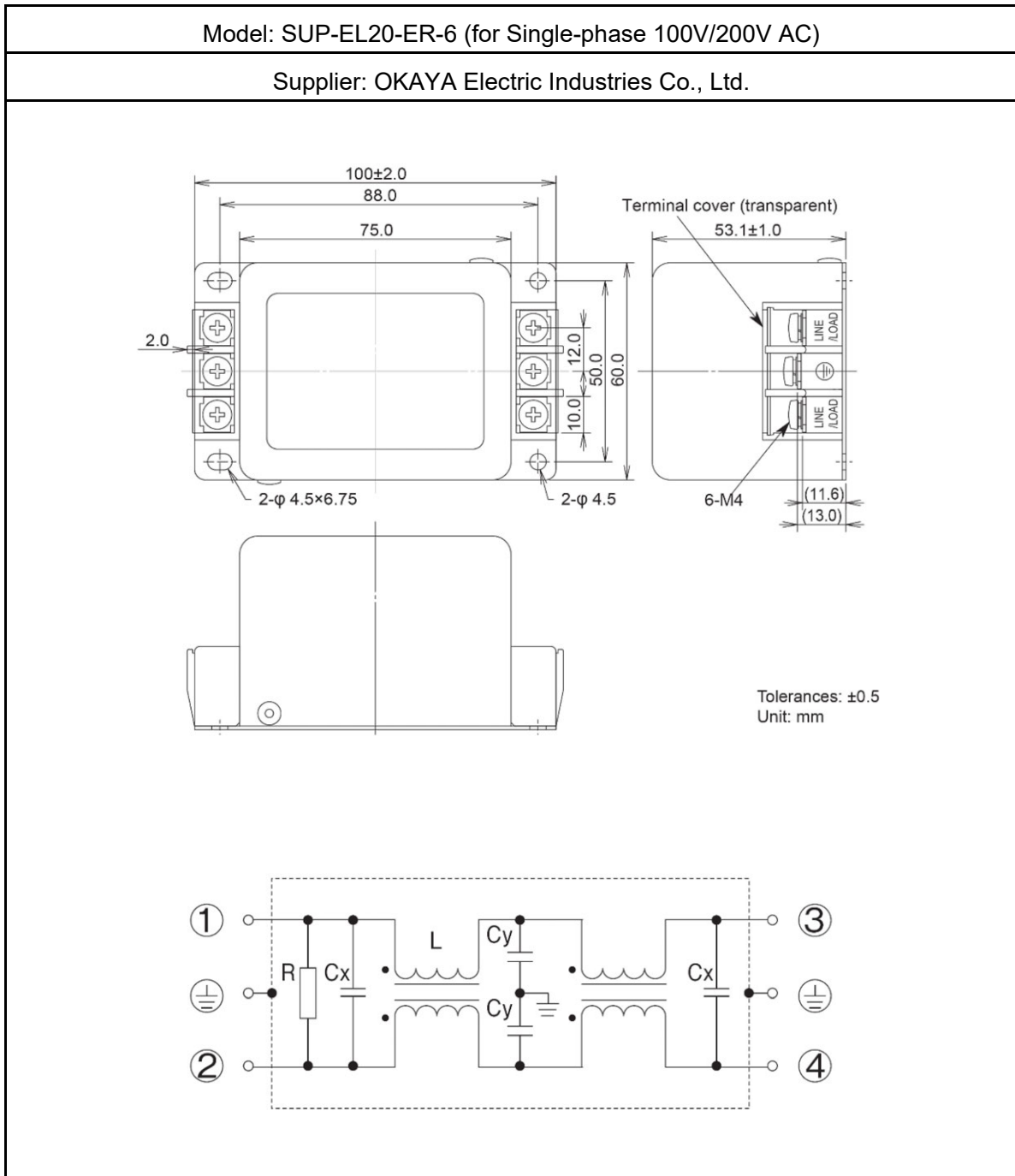

Noise Filter (3)

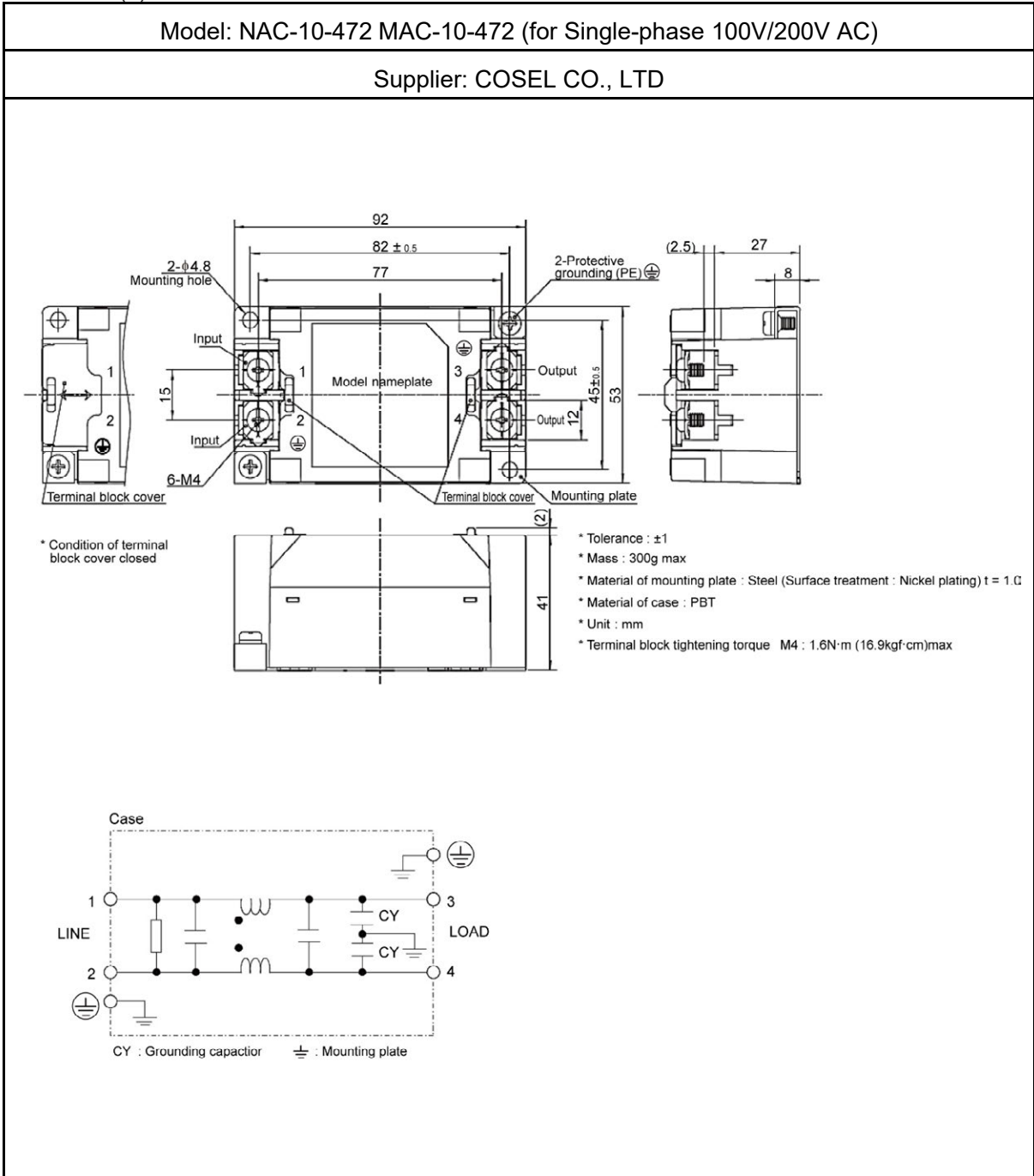

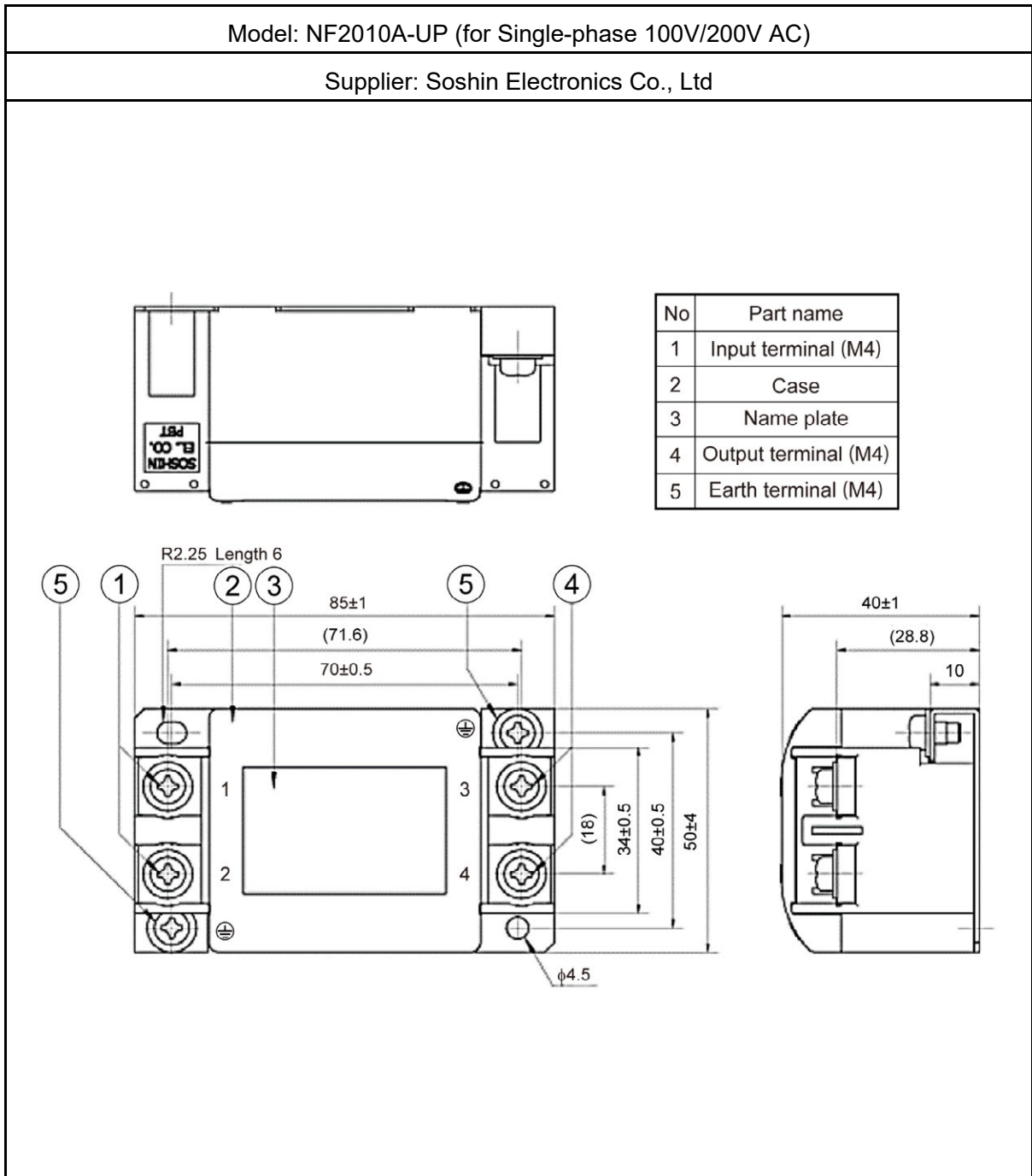

Noise Filter (4)

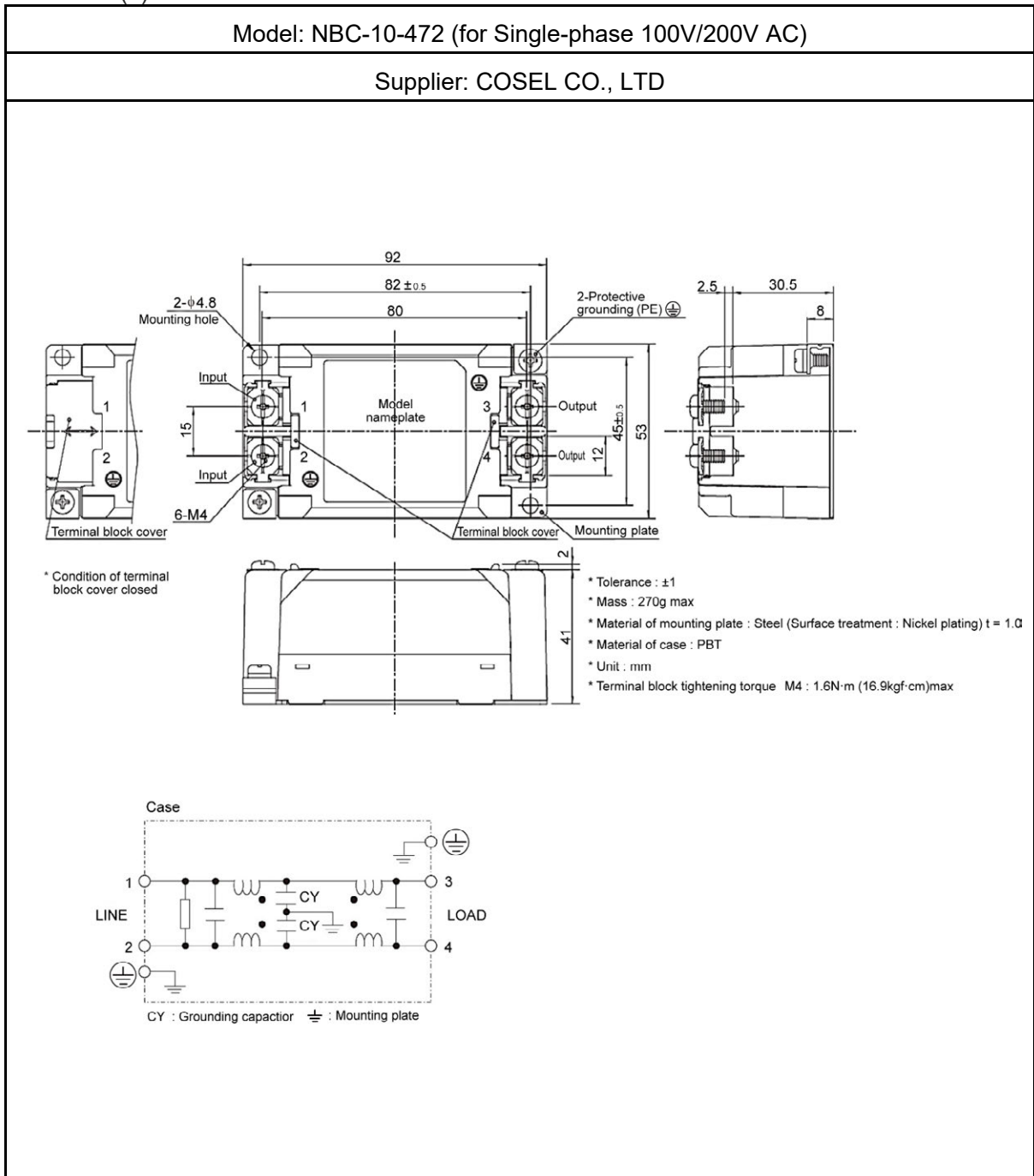

2: CE Marking

Noise Filter (5)

Model: NF3030C-SVF (for 3-phase 200V AC)

Supplier: Soshin Electronics Co., Ltd

The technical drawing includes three views of the noise filter: a front view with dimensions (120±2, 128±4, 40±2, 50±4, 15±2, 78±4, 10.5, 12.5), a side view showing a depth of 15±2, and a rear view showing a name plate with 'SOSHIN EL. CO. PBT' and ventilation slots. Callouts 1 through 6 identify specific terminals and components.

No	Part name	Note
1	Input terminal	M4
2	Case	PBT
3	Name plate	
4	Output terminal	M4
5	Earth terminal	M4

The circuit diagram shows a three-phase transformer with three primary windings connected to terminals 1, 2, and 3 (labeled 'LINE'). The secondary windings are connected to terminals 4, 5, and 6 (labeled 'LOAD'). Each secondary winding has a capacitor connected to it. A PE (Protective Earth) terminal is also shown, connected to the common point of the secondary windings.

Noise Filter (6)

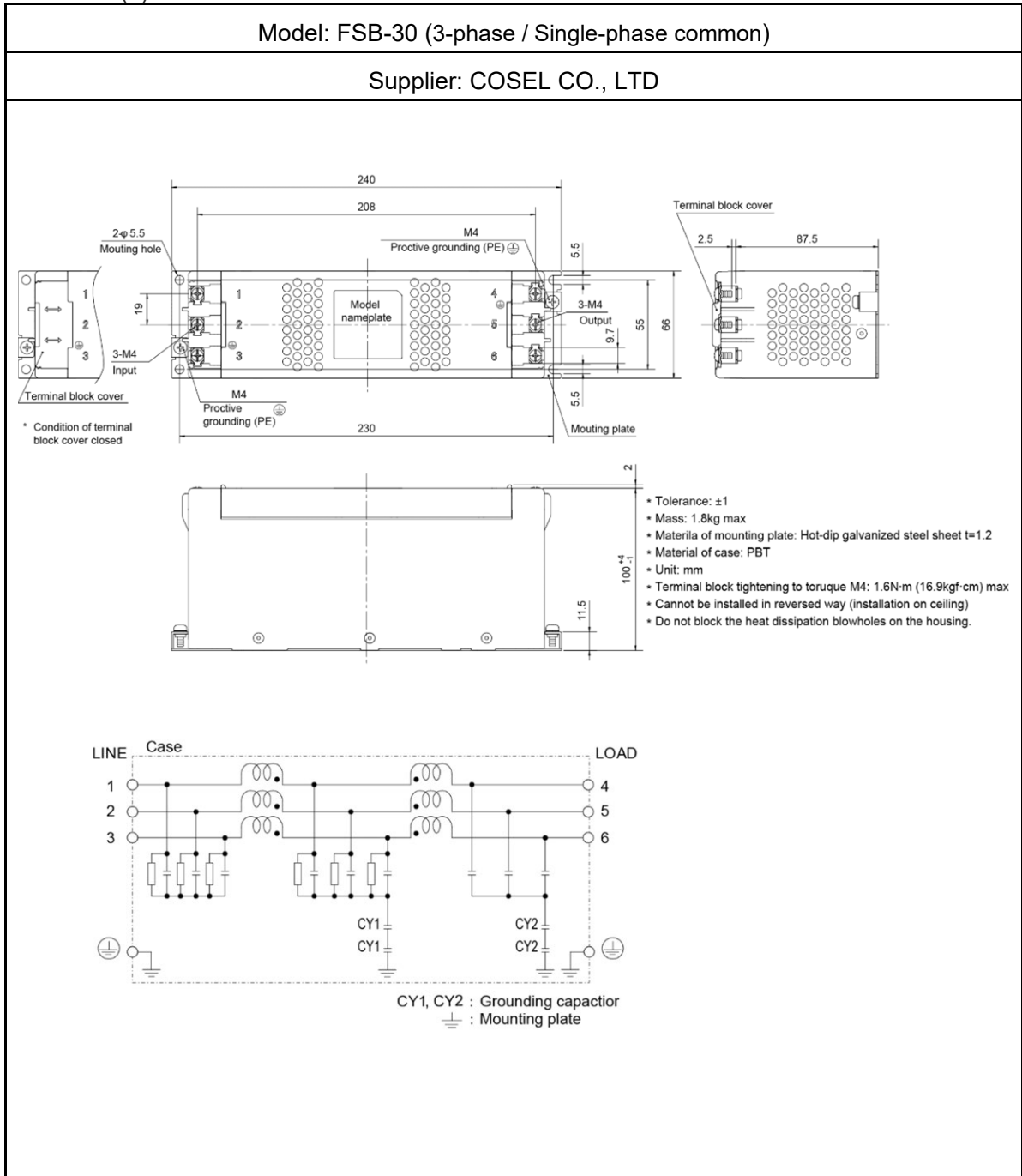

2. CE Marking

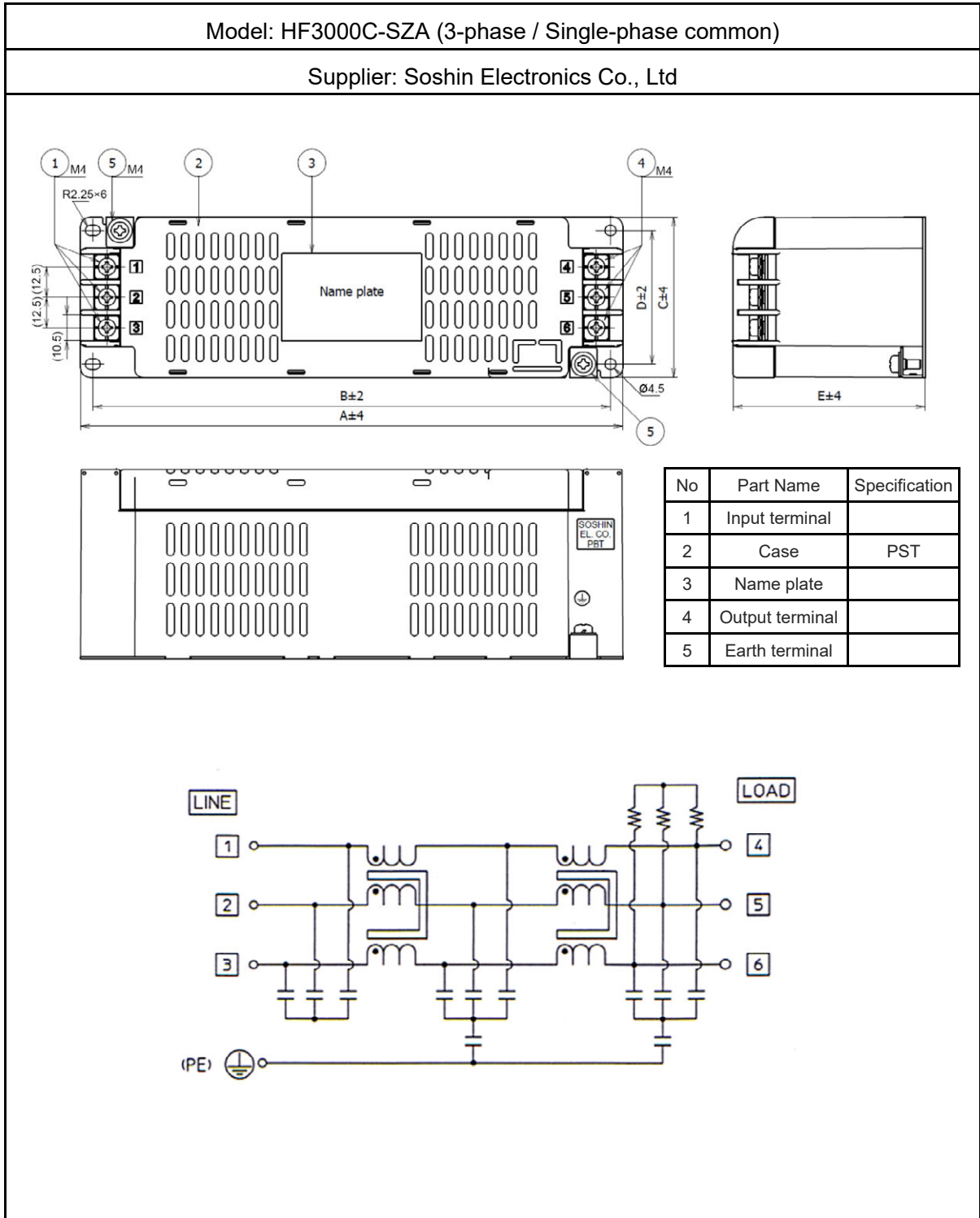

### 2.9.4 Surge Protector

Surge Protector (1)

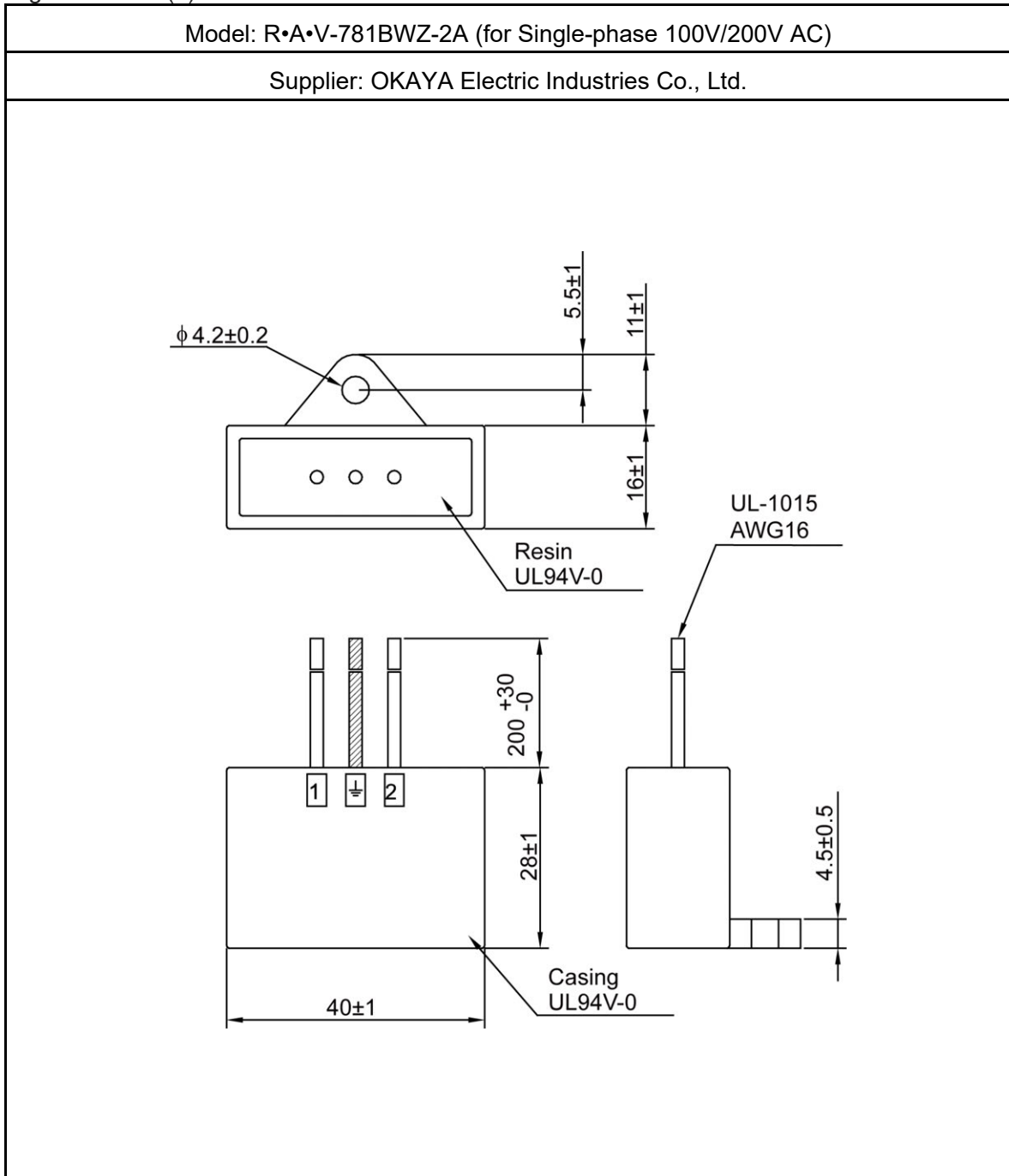

2: CE Marking

Surge Protector (2)

Model: R•A•V-781BWZ-4 (for Single-phase 100V/200V AC)

Supplier: OKAYA Electric Industries Co., Ltd.

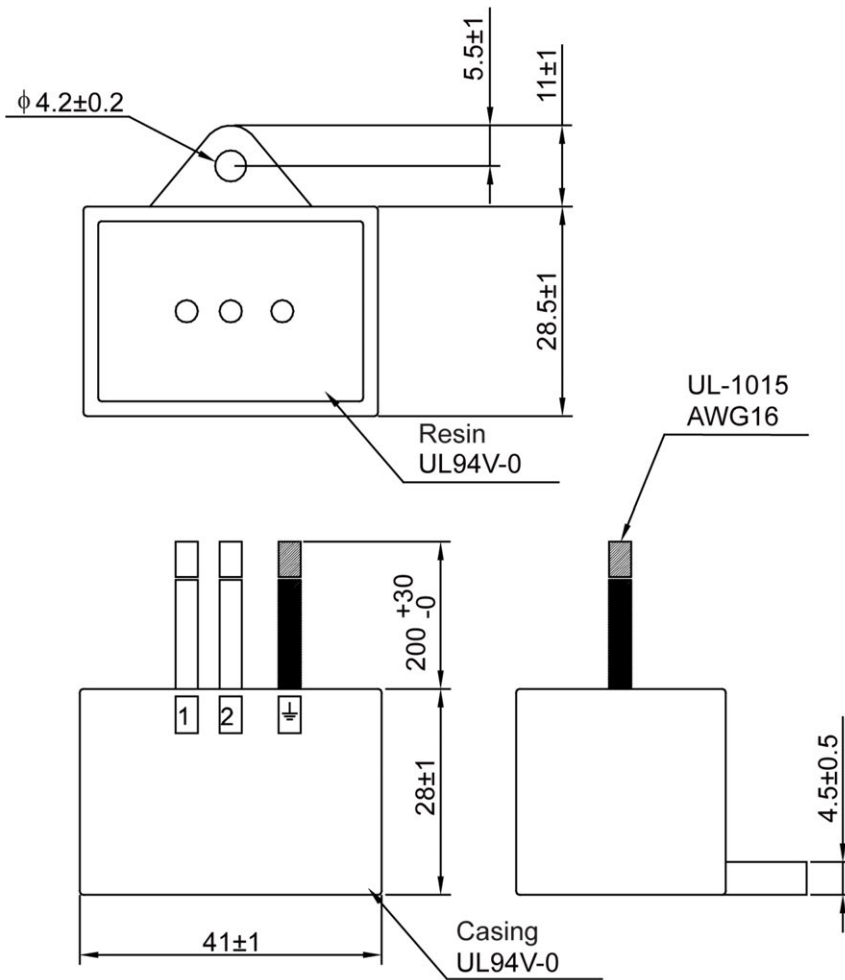

Surge Protector (3)

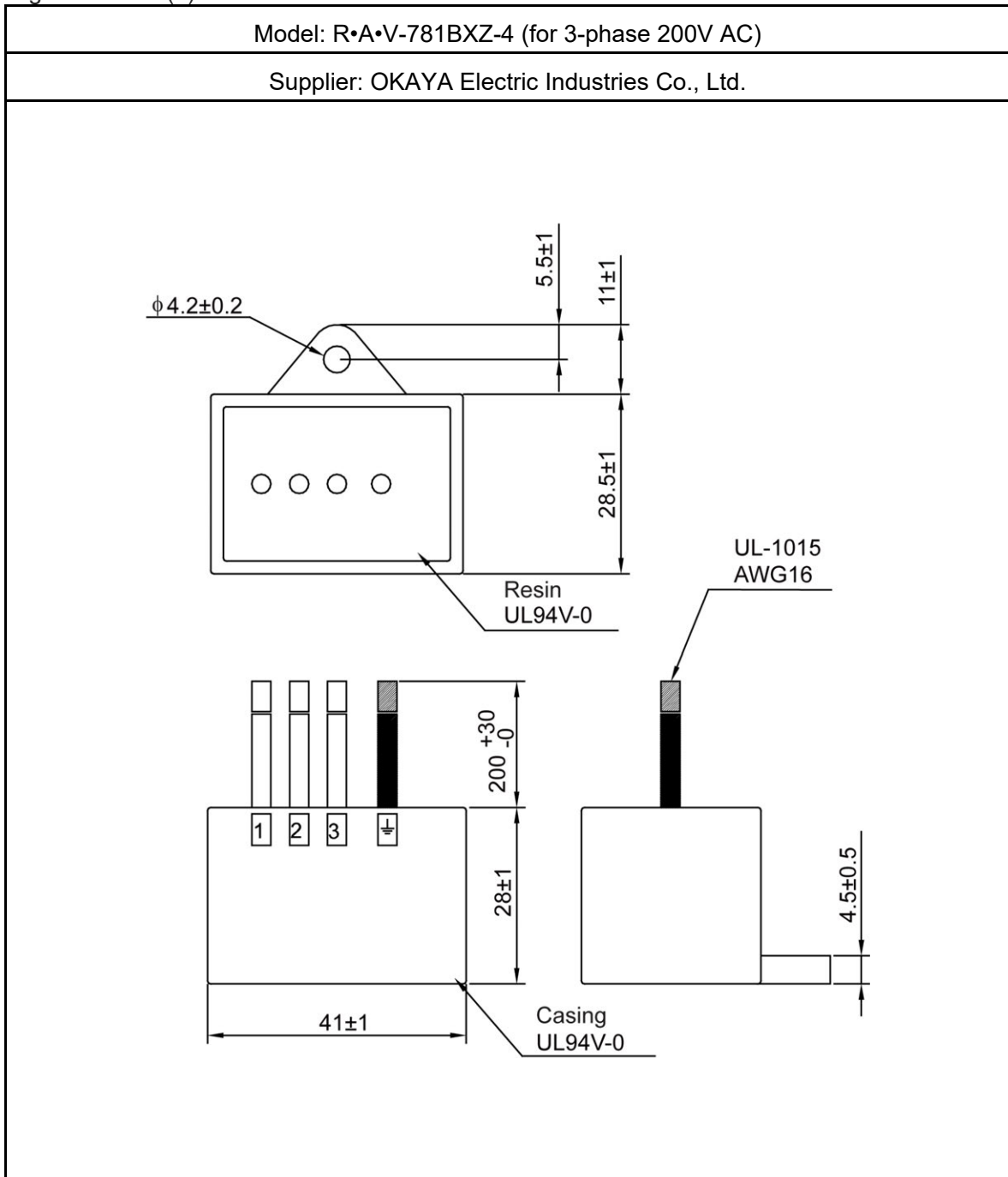

2.9.5 24V DC Power Supply

24V DC POWER SUPPLY (1)

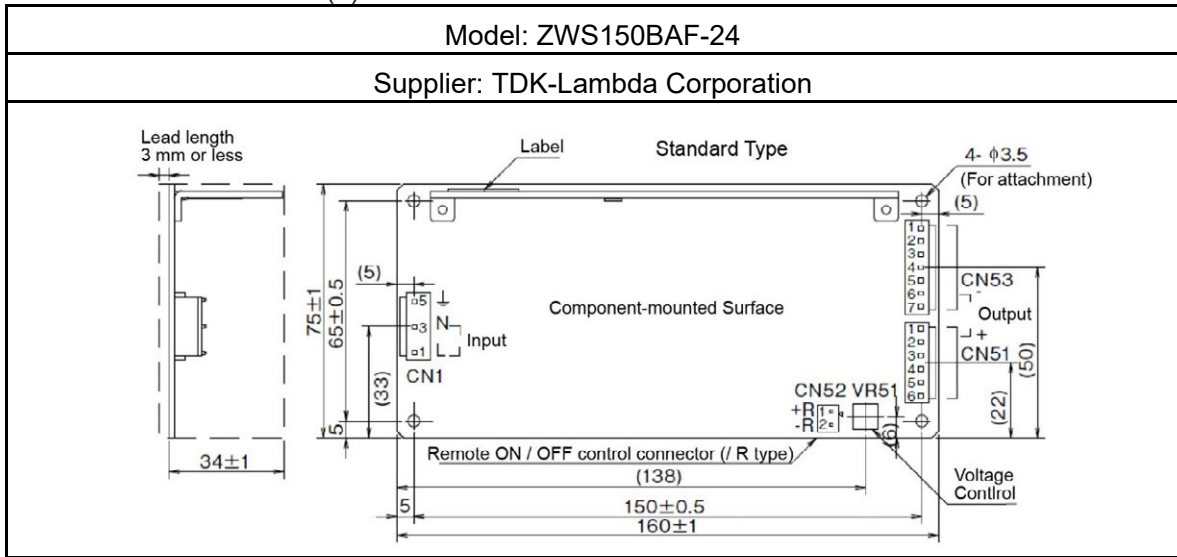

24V DC Power Supply (2)

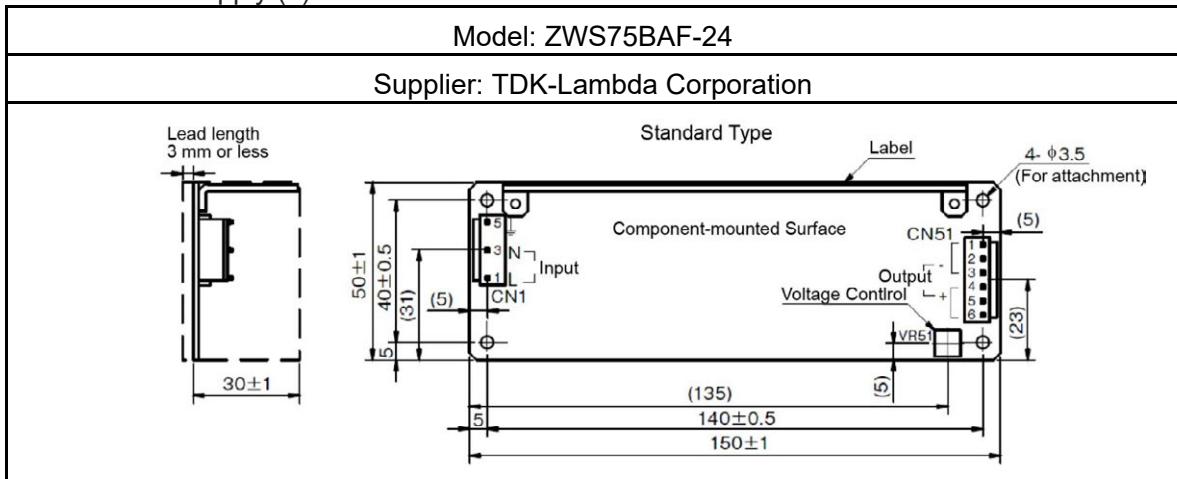

24V DC Power Supply (3)

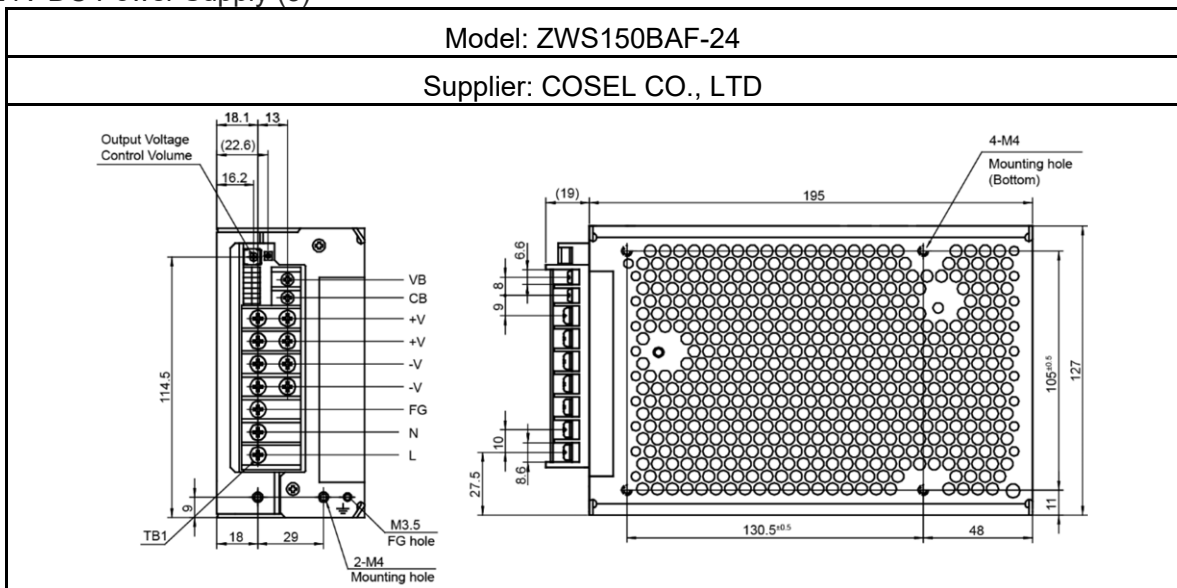

DC Power Supply (4)

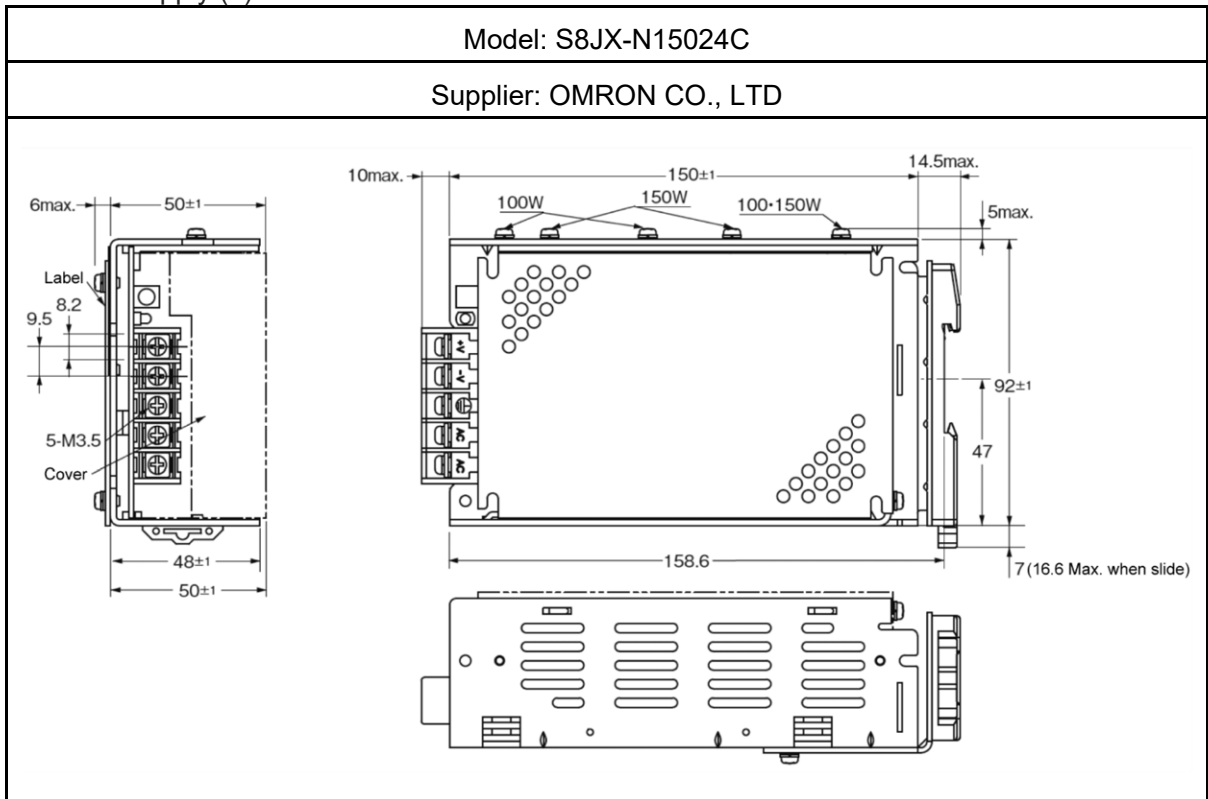

2: CE Marking

24V DC Power Supply (5)

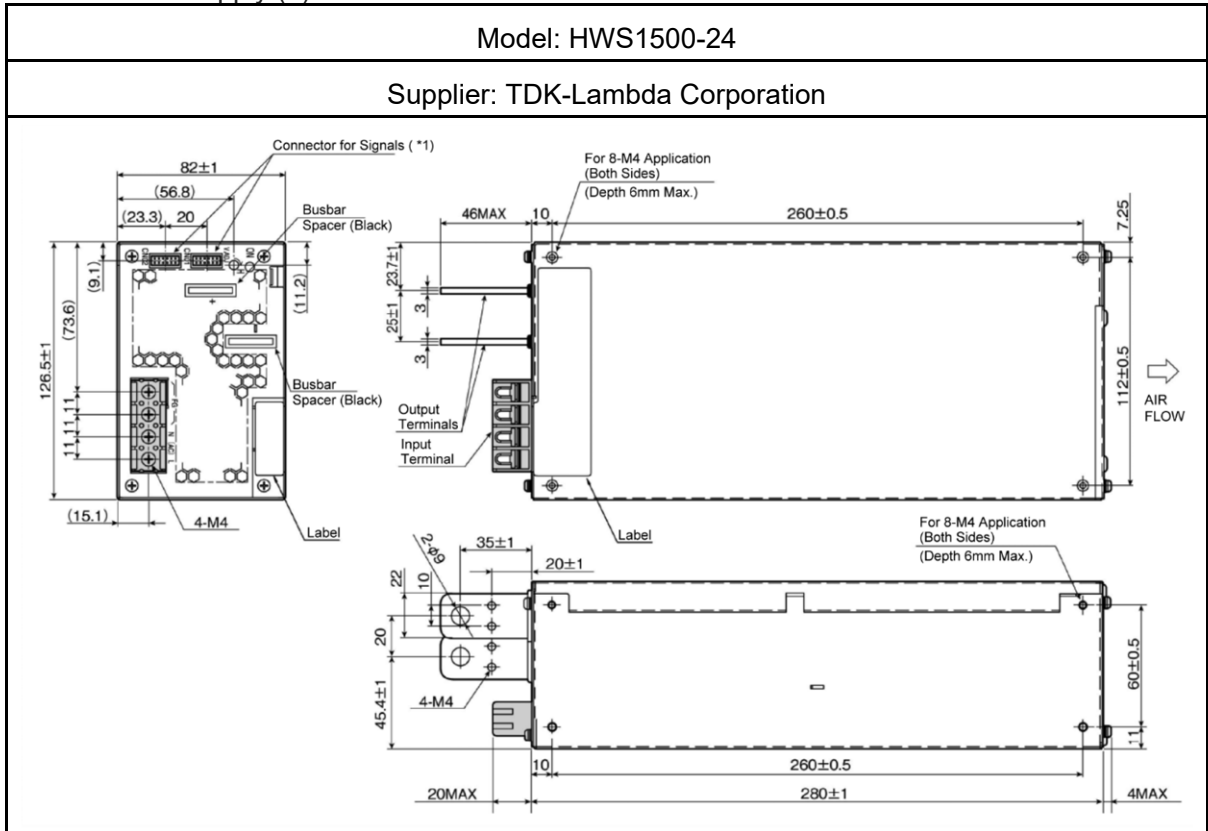

24V DC Power Supply (6)

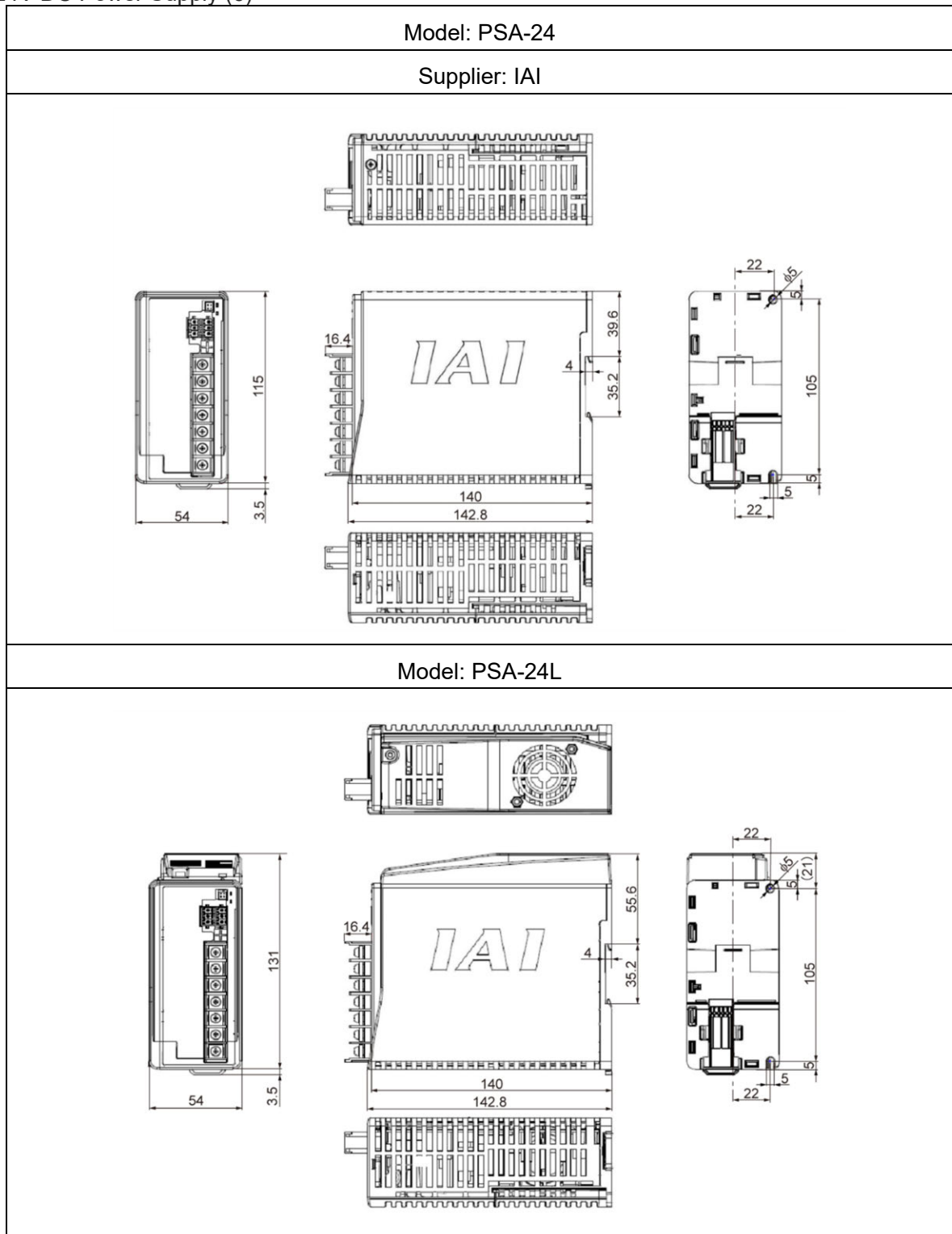

## 2.10 Protection Equipment to Ensure Safety

It is the safety equipment used to each model to ensure the safety.

If the input is 100V/200V AC single phase, 2P type is also available. (In the circuit sample in [Section 2.8], 3P type is shown.)

### 2.10.1 No Fuse Breaker (Circuit Breaker)

No Fuse Breaker (Circuit Breaker) (1)

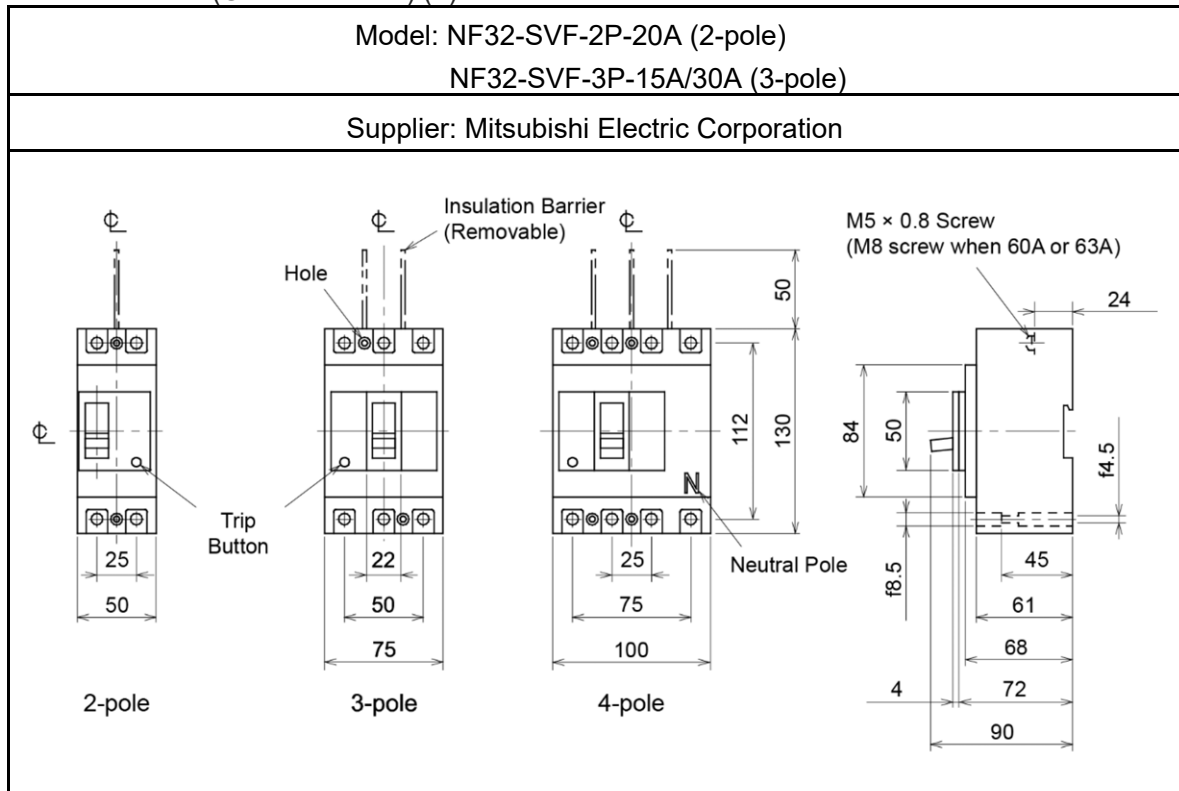

2.10 Protection Equipment to Ensure Safety

No Fuse Breaker (Circuit Breaker) (2)

Model: QOU220 (2-pole)

Supplier: Schneider Electric

2. CE Marking

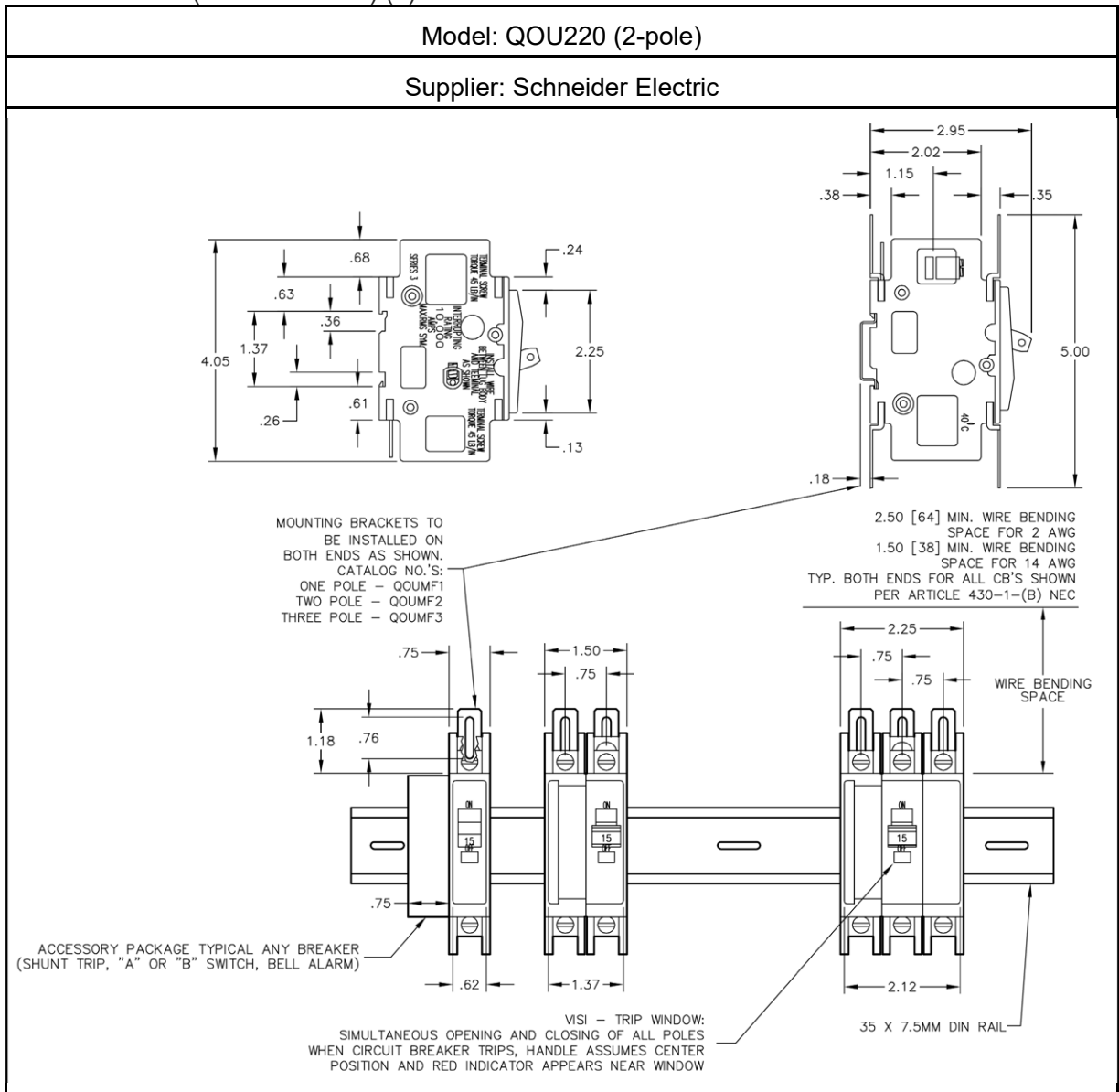

2.10.2 Leakage Breaker

Leakage Breaker (1)

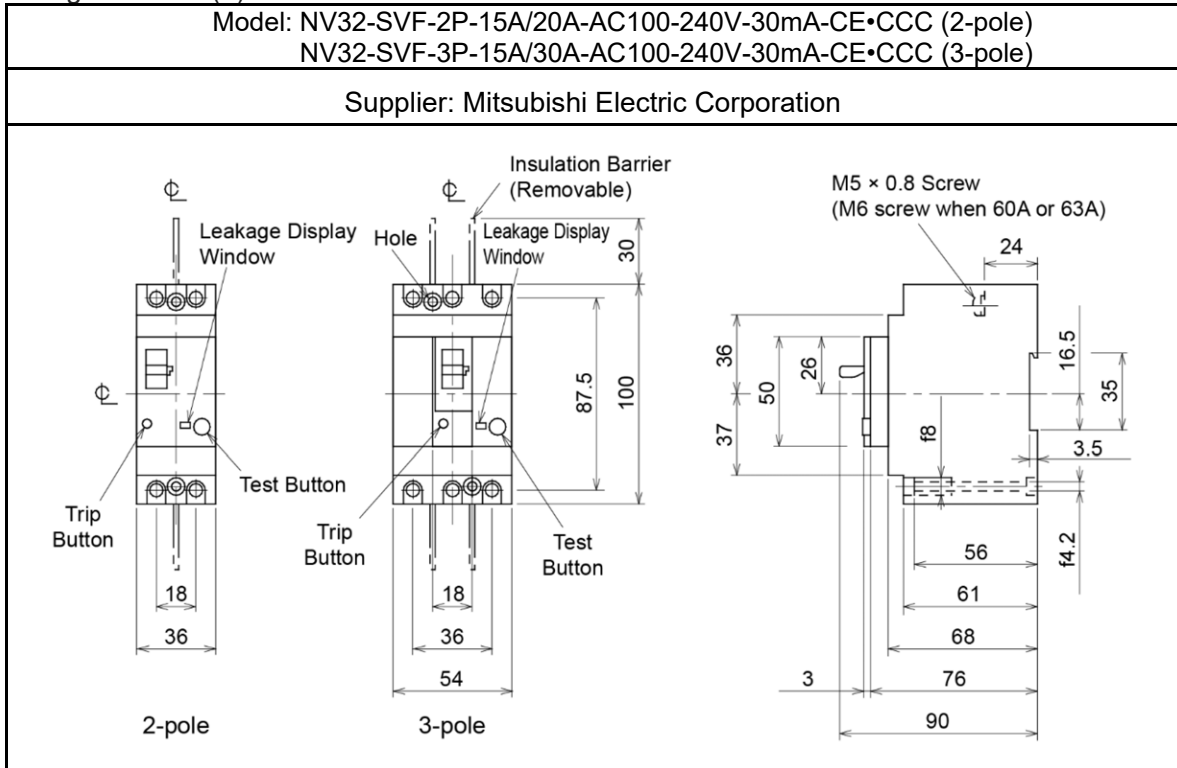

2. CE Marking

### 2.10.3 Contactor

Contactor (1)

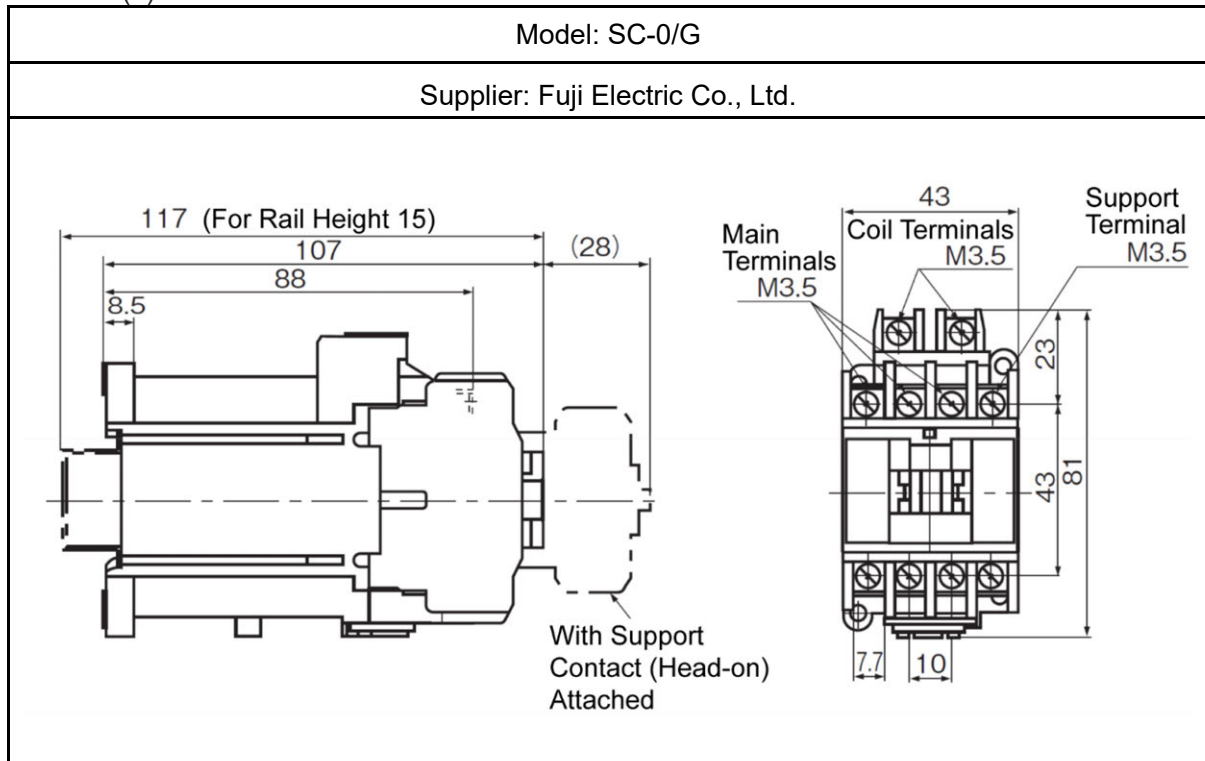

2. CE Marking

### 2.10.4 Safety Relay

#### Safety Relay (1)

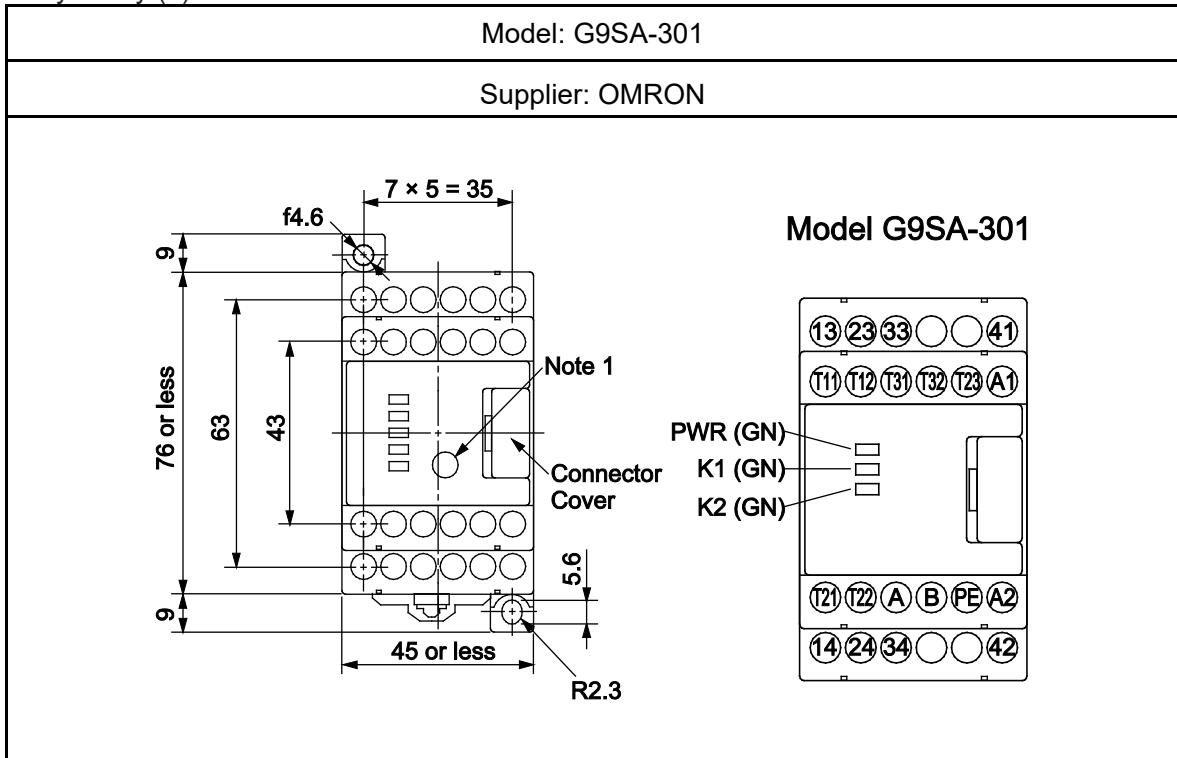

2: CE Marking

2.10.5 Fuse

Fuse (1)

Model: CR2LS-20/UL

Supplier: Fuji Electric Co., Ltd.

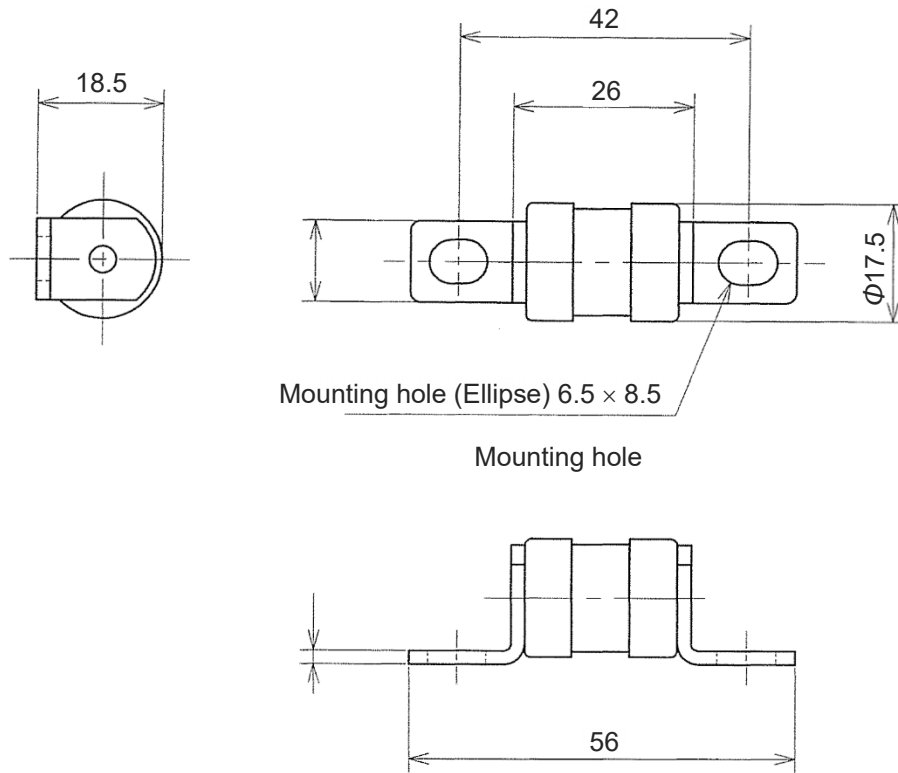

2. CE Marking

**Overseas Standards  
Compliance Manual**

---

**Chapter 3**

# UL Standards

3.1	About UL Standards .....	3-1
3.2	UL Standards List .....	3-2



## 3.1 About UL Standards

UL (Underwriters Laboratories Inc.) is a non-profit organization established by Board of Fire Underwriters in the U.S. in 1894. It conducts researches, evaluations and inspections to protect human lives and properties from fires, disasters, robberies and other accidents.

The UL Standards are the safety standards for products in relation with functions and safety. UL tests and evaluates a sample of its product. When UL judges complied with the requirements in the US Standards, the product gets allowed to label a UL certification mark on delivery.

In the recognized component directory called “Yellow Book”, the registrants, names of materials, ratings and displayed marks for the recognized components subject to components and materials are listed with file numbers.

Please note that using a product registered in the Yellow Book as a part of the final product would not make the final product certified as a UL product.

In IAI products, some of them are certified by the UL standards as shown in the [Chapter 1 Overseas Standards Compliance List] described of this manual.

Contact us for more detailed information in IAI products.

## 3.2 UL Standards List

The list of UL standards compliance products and their certification numbers shown below.

Series Name	Model	UL Number
EC	SL/S/WS/B	UL2011*1
	WER/GDB/CRP/CGD/RP/GD/GS/SRG	UL2011
	R/RR	UL2011
	T/CTC/TC/TW	UL2011
	WEGR/GRB/GRC/GRST/GRTR/GRBP	UL2011
	RTB/RTC	UL2011
	GDS/ST	UL2011
MSEP	C/CL	UL508C
	C-ABB/LC-ABB	UL508C
MCON	C/CG/LC/LCG	UL508C
R-unit	RCON-GW/GWG	UL61800-5-1
	RSEL-G	UL61800-5-1
	REC-GW	UL61800-5-1
	RCON-PC-1/RCON-PC-2	UL61800-5-1
	RCON-PCF-1	UL61800-5-1
	RCON-AC-1/RCON-AC-2	UL61800-5-1
	RCON-DC-1/RCON-DC-2	UL61800-5-1
	RCON-SC-1	UL61800-5-1
	RCON-PS2-3	UL61800-5-1
	RCON-EC-4	UL61800-5-1
	RCON-ABU-P	UL61800-5-1
	RCON-ABU-A	UL61800-5-1
	RCON-EXT	UL61800-5-1
	RCON-EXT-NP/PN	UL61800-5-1
	RCON-NP/PN	UL61800-5-1
PCON	CB/CGB/CFB/CGFB	UL508C
	CBP/CGBP (dedicated for Pulse Press)	UL508C
	CA/CF/CFA	UL508C
	C/CG	UL508C
	CY/SE/PL/PO	UL508C
	CYB/PLB/POB	UL508C
ACON	CB/CGB	UL508C
	CA	UL508C
	C/CG	UL508C
	CY/SE/PL/PO	UL508C
	CYB/PLB/POB	UL508C
DCON	CB/CGB	UL508C
	CA	UL508C
	CYB/PLB/POB	UL508C

\*1 B8SS/S10(X)/S13(X)/S15(X)/S18(X) are not UL complied.

Series Name	Model	UL Number
SCON	CB/CGB/LC/LCG	UL508C*2
	CB-F (dedicated for Servo Press) /LC-F	UL508C*2
	CA	UL508C
SCON2	-	UL61800-5-1
ROBONET	RGW-DV/RGW-CC	UL508C
	RGW-PR/RGW-SIO	UL508C
	RACON/RPCON	UL508C
	RABU	UL508C
	REXT	UL508C
	REXT-SIO	UL508C
	REXT-CTL	UL508C
XSEL	SA/SAX/SAXD8	UL61800-5-1
	Q	UL61800-5-1
	PCT/QCT	UL61800-5-1
EC	PSA-200	UL61800-5-1
EWS	OPS-0524	UL61010-1

\*2 3000 and 3300W types are not UL complied.



**Overseas Standards  
Compliance Manual**

---

**Chapter 4**

# KCs Marking

4.1 About KCs Marking ..... 4-1



## 4.1 About KCs Marking

Since 1 March, 2013, industrial robots has become subject to Labor's Safety Certification System in Korea, which regulates products used in Korea and exported to Korea from Japan.

The industrial robots defined in KCs are described as “a fixed robot, including an orthogonal-coordinate robot, capable of programming and automatic control using a dedicated control device, being equipped with manipulators of more than 3 axes (including a control device equipped with actuators and teaching pendant and communication interfaces) ”.

The products of IAI already applied for and registered to KCs are as listed below:

- All products in IX/IXP/IXA SCARA Robot Series (high velocity types)
- Partially in Single-Axis (contact person in charge for sales in IAI for details)
- TTA Table Top Robot Series



**Overseas Standards  
Compliance Manual**

---

**Chapter 5**

**TSCA**

5.1 About TSCA ..... 5-1



## 5.1 About TSCA

TSCA: Toxic Substances Control Act is a law that is the basic of the chemical regulation of the U.S.A. that is managed by U.S. Environmental Protection Agency (EPA). Purposed to prevent risks to human health and environment, TSCA controls manufacturing, processing and import of harmful chemicals and mixtures.

Based on TSCA Section 6 (h), EPA announced the regulations to prohibit and restrict manufacturing processing and commercial distributions for 5 kinds of chemicals that possess persistent, bioaccumulation and toxicity (PBT substances \*1), and products and goods that contain the subject substances in 2021.

The US TSCA regulations were revised after that, and import to and processing and commercial distribution in the U.S. of any product contains PBT5 substances ha been prohibited have been prohibited since November 1, 2024.

\*1 The PBT substances include the following five kinds:

- Decabromodiphenyl ether (DecaBDE)
- Triphenylphosphate (Isopropylated) (PIP(3:1))
- 2,4,6-Tri-tert-butylphenol (2,4,6-TTBP)
- Hexachlorobuta-1,3-diene (HCBd)
- Pentachlorothiophenol (PCTP)

IAI has confirmed that some of the components of its products such as connectors and fuses contain triphenylphosphate (Isopropylated).

We have identified the parts that contain triphenylphosphate (Isopropylated) and have started to deliver products that comply with TSCA regulations since November 1, 2023. However, for IO cables of XSEL-P/Q and IO conversion cables for TTA, we have started delivery since middle of November, 2023.

For the products complied with TSCA, refer to [Chapter 1 Global Standards Compliance List]. Consult with our person in charge for sales for details.



### Caution

- As some of the old products and maintenance parts may not have replacement, it will be a product that contains the substance regulated in TSCA.
- As the special specifications may contain substances regulated in TSCA, it is necessary to investigate them individually.



**Overseas Standards  
Compliance Manual**

---

**Chapter 6**

# China RoHS

6.1 About China RoHS ..... 6-1



## 6.1 About China RoHS

The Management Measures for the Restriction of the Use of Hazardous Substances in Electrical and Electronic Products (China RoHS (Restriction of Hazardous Substances)) is a regulation aimed at reducing environmental pollution after disposal by restricting the use of hazardous substances contained in electronic equipment. The regulation is administered by China's Ministry of Industry and Information Technology (MIIT) and was jointly promulgated by multiple government agencies, including the Ministry of Environmental Protection (now the Ministry of Ecology and Environment) and the General Administration of Quality Supervision, Inspection and Quarantine (now the State Administration for Market Regulation). The national recommended standard (GB/T 26572-2011 Requirements for concentration limits of certain restricted substances in electrical and electronic products) and the industry recommended standard (SJ/T 11364-2024 Marking for the restriction of hazardous substances in electrical and electronic equipment) have been revised. Beginning January 1, 2026, the number of regulated substances will increase to ten with the addition of four phthalate esters. Furthermore, on August 1, 2027, the national mandatory standard GB 26572-2025 (which replaces GB/T 26572-2011) will come into effect.

The regulated substances are the following ten:

- Lead (Pb)
- Mercury (Hg)
- Cadmium (Cd)
- Hexavalent chromium (Cr(VI))
- Polybrominated biphenyls (PBB)
- Polybrominated diphenyl ethers (PBDE)
- Dibutyl phthalate (DBP)
- Diisobutyl phthalate (DIBP)
- Benzyl butyl phthalate (BBP)
- Bis (2-ethylhexyl) phthalate (DEHP)

Necessary information for compliance with China RoHS is available with us.

For further details, contact our sales representative.



**Overseas Standards  
Compliance Manual**

---

**Chapter 7**

# Wireless Communication Compatible

7.1	About Wireless Communication Compatible .....	7-1
7.2	Caution Regarding Wireless Devices .....	7-3



## 7.1 About Wireless Communication Compatible

For ELECYLINDER (EC) Series, when wireless communication applicable option (model code: WL, WL2) is selected, a wireless communication board should get built in. Certificates and self declarations regarding the wireless function are handled under the model name below for the wireless circuit board.

Model name: IABL3826, IABL3827

Additionally, the WLAN/Bluetooth converter of the wireless teaching system supports wireless communication.

Certifications and declarations related to the wireless function have been obtained/performed under the product model name listed below.

Model name: ICD-WLBT

## 7.1 About Wireless Communication Compatible

Use of this device is permitted within the following countries (regions) only. Use in other countries (regions) requires certification to be obtained based on the laws and regulations of the relevant country (region).

登録モデル名／Registered model name	IABL3826	IABL3827	ICD-WLBT
無線周波数／Wireless frequency	2,400～2,483.5MHz		WLAN (2.4GHz band) : 2,400～2,484MHz WLAN (5GHz band) : 5,150～5,250MHz Bluetooth : 2,400～2,483.5MHz
無線出力／Wireless output	+5dBm		WLAN (2.4GHz band) : +16.3dBm WLAN (5GHz band) : +15.1dBm Bluetooth : +5dBm
メーカー名／Manufacturer name	株式会社アイエイアイ／IAI CORPORATION		
製造国／Country of manufacture	日本／(Made in Japan)		
日本／Japan	* Indicate the Technical Conformity Certification number in Construction Design Certification.		
アメリカ／US	Import Corporation Name	IAI America, Inc.	
カナダ／Canada	Import Corporation Name	IAI America, Inc.	
EU加盟国, イギリス／EU Member States, UK	Import Corporation Name	IAI Industrieroboter GmbH	
中国／China	许可编号	CMIT ID=2017DJ6836	CMIT ID=2018DJ0331
	申请公司名	IAI 株式会社	
	机型号	IABL3826	IABL3827
	制造国	日本 (Made in Japan)	
	进口企业名	IAI (Shanghai) Co., Ltd.	
한국／KOREA	식별 부호	MSIP-CRM-IAI-IABL3826	R-CRM-IAI-IABL3827
	제조사명	주식회사 IAI	
	모델명	IABL3826	IABL3827
	제조국	일본 (Made in Japan)	
	수입업자명	IA KOREA Corp.	
ประเทศไทย／Thailand	ผู้ผลิต	IAI CORPORATION.	
	ชื่อโมเดล	IABL3826	IABL3827
	ประเทศผู้ผลิต	ญี่ปุ่น (Made in Japan)	
	ผู้นำเข้า	IAI Robot (Thailand) Co., Ltd.	
México / Mexico	Número de Certificación	IFT : RCPIATB19-1956-A1	IFT : RCPIATB19-1956
	Nombre de la Empresa Solicitante	IAI Corporation	
	Nombre del Modelo	IABL3826	IABL3827
	País de Fabricación	Japón (Hecho en Japón)	
	Nombre de la Empresa Importadora	IAI America, Inc.	

## 7.2 Caution Regarding Wireless Devices

This product uses the 2.4 GHz and 5GHz band radio band known as an ISM band. This frequency range is used by various devices such as microwave ovens and wireless LAN, so that communication may be disrupted by radio disturbance.

Note that outdoor use of the 5 GHz band is prohibited by the regulations of countries such as Japan and those in Europe.

### [US]

**This device complies with Part 15 of the FCC Rules. Operation is subject to the following two conditions:**

1. This device may not cause harmful interference and
2. This device must accept any interference received, including interference that may cause undesired operation of the device.

### **FCC RF Radiation Exposure Statement:**

This equipment complies with FCC radiation exposure limits set forth for an uncontrolled environment. End users must follow the specific operating instructions for satisfying RF exposure limits. This transmitter must not be collocated or operating with any other antenna or transmitter.

### [CANADA]

**This device complies with Industry Canada licence-exempt RSS standards.**

Operation is subject to the following two conditions:

1. This device may not cause interference, and
2. This device must accept any interference, including interference that may cause undesired operation of the device

**Le présent appareil est conforme aux CNR d'Industrie Canada applicables aux appareils radio exempts de licence**

L'exploitation est autorisée aux deux conditions suivantes:

1. l'appareil ne doit pas produire de brouillage, et
2. l'utilisateur de l'appareil doit accepter tout brouillage radioélectrique subi, même si le brouillage est susceptible d'en compromettre le fonctionnement.

### **IC RF Radiation Exposure Statement:**

To comply with IC RF exposure requirements, this device and its antenna must not be co-located or operating in conjunction with any other antenna or transmitter.

Pour se conformer aux exigences de conformité RF canadienne l'exposition, cet appareil et son antenne ne doivent pas être co-localisés ou fonctionnant en conjonction avec une autre antenne ou transmetteur.

### **[日本]**

本製品で使用している無線モジュールは、工事設計認証を受けていますので、以下の事項を行うと法律で罰せられることがあります。

- 無線モジュールを分解/改造すること

### **[EU Member States, UK]**

- For details of the applicable standards, please refer to above mentioned international standards compliances.
  - \* The product can be used in any country which is a member of EU.

### **[한국/KOREA]**

해당 무선설비는 전파혼신 가능성이 있으므로 인명안전과 관련된 서비스는 할 수 없습니다



Revision history

Revision date	Revised content
2012.08	Section 1.8.11 to 1.8.13 : Power supply added Section 1.9.2 : Power supply specification of earth leakage added
2013.09	Sixth edition MSEP and PCON-CA/CFA comply with UL.
2014.04	Seventh edition Model complies with KCs added to lineup, etc.
2015.04	Eighth edition Pg 1 to 3 : Applicable models added in oversea standards compliance list Pg 4 : Applicable models added Pg 5 : Related standard numbers added and names changed Pg 8 : Altitude standard revised Pg 15 to 16 : Applicable controllers added, applicable actuators added Pg 21 : RCP5 added Pg 34 : ERC3 added Pg 36 : Models added (MSEL-PGX) Pg 52 : IXP added in Kcs Section
2016.05	Ninth edition Pg 1 to 7, 17 : Applicable models added and applicable cable model displayed
2016.07	Tenth edition Pg 4, 20, 31 : MSCON added Pg 52 : Noise filter (4) added
2016.08	10B edition Compliance of IAI Corporation to Safety Standards " If you need another language to apply, please contact our sales window." added Pg 20 to 22, 24 to 30, 32, 34, 36, 41 : Correction made
2016.09	10C edition Pg 17 : Table correction Pg 24 : PSEP-C/CW added Pg 27 : SCON-CAL/CGAL/CB/CGB/LC/LCG added Pg 41 : MSEL-PC/PG added
2016.12	10D edition Pg 4 : SCON-CAL/CGAL/CB/CGB/LC/LCG added MSEL-PC/PG added

Revision history

Revision date	Revised content
2017.02	10E edition Pg 5, 31, 33, 35, 37 : X-SEL-RA/SA/RAX/SAX/RAXD/SAXD added
2017.07	10F edition Pg 4, 7, 18, 19 : Applicable models added Section 1.7.4 : ACON-CYB/PLB/POB, DCON-CYB/PLB/POB added Section 1.7.5 : PCON-CYB/PLB/POB added Section 1.7.10 to 13 : Statement revised for XSEL Section 1.7.16 : MSEL-PCF/PGF added and correction made to -PGX
2018.07	Eleventh edition <ul style="list-style-type: none"> <li>• Oversea Standards Compliance List : Models added e.g. EC, IXA, RCON</li> <li>• Section 1.7 : SCON-CGB (for 3000W and 3300W motors), RCS4/RCS4CR, IXA and RCON added in table for actuators combined with each controller</li> <li>• Section 1.7.7 : SCON-CGB (For the 3000W and 3300W Motor) added</li> <li>• Section 1.7.12 to 13 : IXA added</li> <li>• Section 1.7.18 : RCON added</li> </ul>
2019.07	11B edition <ul style="list-style-type: none"> <li>• Oversea Standards Compliance List : XSEL-Q/QCT and XSEL-SA comply with UL standards.</li> </ul>
2020.01	11C edition <ul style="list-style-type: none"> <li>• Please Read Before Use: Descriptions revised</li> </ul>
2020.04	Twelfth edition <ul style="list-style-type: none"> <li>• Overseas Standards Compliance List: New EC models added</li> <li>• Section 1.7 : RSEL-G, REC-GW, EC added</li> <li>• Section 1.7.19 : RSEL-G added</li> <li>• Section 1.7.20 : REC-GW added</li> <li>• Section 1.7.21 : ELECYLINDER added</li> <li>• Section 1.8.1 : Clamp Filter (4) added</li> </ul>
2020.06	Thirteenth edition <ul style="list-style-type: none"> <li>• Overseas Standards Compliance List: Corresponding model added</li> <li>• 1, 1.3, 1.4 : Descriptions revised</li> <li>• 1.7.20 : RCON-SC added</li> <li>• 1.7.23 : EC 200V added</li> <li>• Correction made, Terms unified</li> </ul>
2021.03	13B edition <ul style="list-style-type: none"> <li>• Correction made</li> </ul>

Revision history

Revision date	Revised content
2021.07	<p>Fourteenth edition</p> <ul style="list-style-type: none"> <li>• Compliance of IAI Corporation to Safety Standards               <ol style="list-style-type: none"> <li>1. Sentences revised regarding UL</li> <li>2. Explanation revised in accordance with compliance with revised RoHS Directive in relation to EC Directive</li> </ol> </li> <li>• Overseas Standard Compliance List :               <ul style="list-style-type: none"> <li>Change made to table format</li> <li>UL compatible added •REC-GW, RCON-PS2-3, RCON-SC-1 and RCON-EC-4</li> <li>Lineup added in IXA</li> <li>IXP Dustproof/Splash Proof, TT and XSEL-R/S changed to models not complied with revised RoHS Directive</li> </ul> </li> </ul>
2021.07	<ul style="list-style-type: none"> <li>• 1.1 : RoHS Directive changed to Revised RoHS Directive</li> <li>• 1.3.1 : Descriptions revised for reference of applicable models</li> <li>• 1.7.13 : Wiring diagram of XSEL-SAX4 (high capacity types) and EMC countermeasure components and example of protection devices and power supply to secure safety added</li> <li>• 1.7.14: TT deleted from title</li> <li>• 1.8.3 : Noise filter (NF3030C-SVF) added</li> </ul>
2022.04	<p>Fifteenth edition</p> <p>Following product added in Overseas Standards Compliance List</p> <ul style="list-style-type: none"> <li>• EC (ST15ME): New model</li> <li>• EC Slider (Long stroke, wide reversed)</li> <li>• EC Rod (Double Guide) (SRG11□/SRG15□): New model</li> <li>• EC (Cleanroom Specifications)               <ul style="list-style-type: none"> <li>Slider (Wide) (D)WS10□CR/(D)WS12□CR: New model</li> </ul> </li> <li>• EC (Dustproof) Slider (Dustproof) S6□D/S7□D: New model</li> <li>• EC (Dustproof/Splash Proof)               <ul style="list-style-type: none"> <li>Slider (Dustproof/Splash Proof) S6□W/S7□W: New model</li> </ul> </li> <li>• EC (Ultra mini ELECYLINDER): New model</li> <li>• IFA</li> <li>• IXA: High-Speed Type Cleanroom Specifications</li> </ul> <p>1.1 : Correction made to description of related standards, supplemental comments added</p> <p>1.7 : IFA added to Construction of Peripheral Devices and Applicable Units</p>
2022.08	<p>15B edition</p> <p>Following new product added in Overseas Standards Compliance List</p> <ul style="list-style-type: none"> <li>• EC Large Slider</li> <li>• EC Rotary</li> <li>• IXA High Payload Type</li> <li>• IXA High Speed Dust &amp; Splash Proof Specification, High Payload Type Dust &amp; Splash Proof Specification</li> <li>• Correction made partially to EC models</li> </ul>

Revision history

Revision date	Revised content
2022.12	15C edition Correction made Overseas Standards Compliance List Change XSEL-SAX/SAXD8 to UL Standards Compliance are not complied
2022.12	15D edition Following new product added in Overseas Standards Compliance List <ul style="list-style-type: none"> <li>• EC Slider (Long stroke reversed)</li> <li>• EC High Stiffness (Long stroke reversed)</li> <li>• EC Cleanroom specification (Long stroke reversed, High Stiffness Long stroke reversed)</li> </ul>
2023.05	15E edition Following new product added in Overseas Standards Compliance List <ul style="list-style-type: none"> <li>• EC Slider Belt-Drive (B8S/B8SS)</li> <li>• EC DC Power Supply for Motor Drive (PSA-200)</li> </ul> Updated the correspondence status of the Overseas Standards Compliance List table
2023.06	15F edition Following new product added in Overseas Standards Compliance List <ul style="list-style-type: none"> <li>• EC Slider Type (S8)</li> <li>• EC Radial Cylinder Type (RR8/RR10)</li> <li>• Rotary Chuck (RTCKSRE/RTCKMRE/RTCKSRI/RTCKMRI)</li> <li>• SCON2</li> <li>• Brake Release Box (BKR-01)</li> </ul>
2023.10	Sixteenth edition <ul style="list-style-type: none"> <li>• The format changed</li> <li>• Change made to chapter setting</li> <li>• Wireless Communication Compatible added</li> <li>• SCON2-CG SU (Functional Safety Unit) added</li> <li>• Models in EC gripper type added</li> <li>• 2.9.2 Ring Core manufacturer changed, and correction made to other related areas (NEC TOKIN Corporation → TOKIN Corporation)</li> </ul>
2023.11	16B edition CE compliance <ul style="list-style-type: none"> <li>• RESU-1, RESUD-1, RESU-2, RESUD-2</li> </ul>
2024.02	Seventeenth edition <ul style="list-style-type: none"> <li>• Compliance with TSCA added (Items added in Global Standards Compliance List, preliminaries Item 4 and Chapter 5 added)</li> <li>• Application for Wireless Communication shifted down to Chapter 6</li> </ul>

Revision history

Revision date	Revised content
2024.02	<ul style="list-style-type: none"> <li>• Following added to Global Standard Compliance List               <ul style="list-style-type: none"> <li>• EC Slider Type (S2□)</li> <li>• EC Radial Cylinder Type (RR2□)</li> </ul> </li> <li>• Following deleted from Global Standard Compliance List               <ul style="list-style-type: none"> <li>• Motor cable : CB-CT4-MA, CB-CT4R-MA</li> <li>• Encoder cable : CB-CT4-PA, CB-CT4R-PA, CB-CT4PR-PA</li> </ul> </li> </ul>
2024.04	<p>17B edition</p> <p>Following new product added in Overseas Standards Compliance List</p> <ul style="list-style-type: none"> <li>• EC Ultra Mini (RP3/GD3/TC3/TW3)</li> <li>• EC Compact (CRP3/CRP5/CGD3/CGD5/CTC3/CTC5)</li> </ul> <p>Updated the Overseas Standards Compliance List</p> <ul style="list-style-type: none"> <li>• SCON2 UL compliance</li> <li>• Functional Safety Unit SU UL compliance</li> </ul>
2024.06	<p>Eighteenth edition</p> <p>Overseas Standards Compliance List</p> <p>The data described the following products added</p> <ul style="list-style-type: none"> <li>• EC 3-Finger Gripper (GRTR14M)</li> <li>• RCP6 High Stiffness Slider (HSA6(X)C/HSA7(X)C, HSA6(X)□R/HSA7(X)□R)</li> </ul> <p>Options Correction made to MPG Cable</p> <p>Correction made to Overseas Standards Compliance List, Options and MPG Cable</p> <p>Section 3.2 The UL Standards List added</p>
2024.08	<p>18B edition</p> <p>Addition and change made to Overseas Standards Compliance List</p> <p>Models Added:</p> <ul style="list-style-type: none"> <li>• ELECYLINDER High Stiffness Slider (EC-S8□AH/S8X□AH/S8□AHR/S8X□AHR)</li> <li>• ELECYLINDER High Stiffness Slider Cleanroom specification (S8□AHCR/S8X□AHCR)</li> <li>• Conveyor Control Motor</li> <li>• ROBO PUMP</li> </ul> <p>Option Added:</p> <ul style="list-style-type: none"> <li>• Motor Cable (CB-RCC1-MA<sup>***</sup>)</li> <li>• Driving Battery (AB-8)</li> </ul> <p>Note added for option complied with EU Battery Regulation (2023/1542) (Subject Models : AB-1, AB-3, AB-4, AB-5, AB-6, AB-7, AB-8)</p>
2024.09	<p>18C edition</p> <p>Overseas Standards Compliance List</p> <p>The data described the following products added</p> <ul style="list-style-type: none"> <li>• ELECYLINDER Small Stopper Cylinder (ST9(C))</li> <li>• ELECYLINDER Rod (Double Guide) (SRG9□)</li> <li>• XSEL2</li> </ul>

Revision history

Revision date	Revised content
2024.09	Section 2.8 The notation of some of the Construction of Peripheral Devices and Applicable Units has been revised. 2.9.3 (2) Noise Filter added.
2025.03	18D edition 2.8.13 Changed illustration of for 3-phase Power Supply : IXA 2.8.14 Changed illustration of for 3-phase Power Supply : IXA and IXA (XSEL-SAX4_high capacity types)
2025.05	Nineteenth edition Overseas Standards Compliance List: Changes to the contents of EC and Corresponding model added Note sentence added in Page 1-5 2.8.11 XSEL2 added 3.2 EC models added to UL Standards List
2025.07	19B edition 2.8.26 ROBO PUMP added
2025.11	19C edition Overseas Standards Compliance List: e-Wiring System Connection Unit added 2.8.27 On-Site Power Supply Unit added 2.10.1 No Fuse Breaker (Circuit Breaker) (2) added
2025.12	Twentieth edition Contents of Chapter 6 China RoHS added
2026.04	20B edition Following new product added and updated in Overseas Standards Compliance List <ul style="list-style-type: none"> <li>• Wire Controller</li> <li>• Smart Web Unit</li> <li>• WLAN/Bluetooth Converter</li> <li>• Ethernet/RS-485 Converter</li> </ul> Updated the Overseas Standards Compliance List 2.8 Caution added for wireless devices (WLAN/Bluetooth converter) Chapter 7 ICD-WLBT column added in table Contents added for wireless devices (WLAN/Bluetooth converter)







## ***IAI Corporation***

Head Office: 1210 Ihara Shimizu-KU Shizuoka City Shizuoka 424-0114, Japan  
TEL +81-54-364-5105 FAX +81-54-364-2589  
website: [www.iai-robot.co.jp/](http://www.iai-robot.co.jp/)

## ***IAI America, Inc.***

Head Office: 2690 W. 237th Street, Torrance, CA 90505  
TEL +1-310-891-6015 FAX +1-310-891-0815  
Chicago Office: 110 East State Parkway, Schaumburg, IL 60173  
TEL +1-847-908-1400 FAX +1-847-908-1399  
Atlanta Office: 1220 Kennestone Circle, Suite 108, Marietta, GA 30066  
TEL +1-678-354-9470 FAX +1-678-354-9471  
website: [www.intelligentactuator.com](http://www.intelligentactuator.com)

Technical Support available in Europe

## ***IAI Industrieroboter GmbH***

Ober der Röth 4, D-65824 Schwalbach am Taunus, Germany  
TEL +49(0)6196-88950 FAX +49(0)6196-889524  
website: [www.iai-automation.com](http://www.iai-automation.com)

Technical Support available in Great Britain



Duttons Way, Shadsworth Business Park, Blackburn, Lancashire, BB1 2QR, United Kingdom  
TEL +44(0)1254-685900  
website: [www.lcautomation.com](http://www.lcautomation.com)

## ***IAI (Shanghai) Co., Ltd.***

SHANGHAI JIAHUA BUSINESS CENTER A8-303, 808, Hongqiao Rd. Shanghai 200030, China  
TEL +86-21-6448-4753 FAX +86-21-6448-3992  
website: [www.iai-robot.com](http://www.iai-robot.com)

## ***IAI Robot (Thailand) Co., Ltd.***

825 PhairojKijja Tower 7th Floor, Debaratana RD., Bangna-Nuea, Bangna, Bangkok 10260, Thailand  
TEL +66-2-361-4458 FAX +66-2-361-4456  
website: [www.iai-robot.co.th](http://www.iai-robot.co.th)